



PANTHER T14R

Operating and
maintenance manual

Vehicle number

935310133 and up

--	--	--	--	--	--	--	--	--	--



41240905 rev01

Feb 2019

Pinotti

PRINOTH Ltd.
1001 J.-A.-Bombardier Street
Granby, Qc, Canada, J2J 1E9

™ and ® are trademarks of PRINOTH Ltd. or its affiliated companies used under license.

© 2019 PRINOTH Ltd. All rights reserved. In the USA, the products are distributed by PRINOTH Ltd. (USA) LLC.

No parts of this manual may be reproduced in any form without the prior written permission of PRINOTH Ltd.

This manual may be translated into another language. In the event of any discrepancy, the English version shall prevail.

Printed in Canada

Visit us at www.prinoth.com for more information.

Original instructions

Important notes about this manual

Keep this manual in the cab of the vehicle as a handy reference for the safe and productive use of the Panther T14R. Should you re-sell the vehicle, leave this manual with it for the next owner.

This manual is filled with important safety information - read and understand the content as well as all safety stickers installed on the vehicle.

All products and company names are trademarks™ or registered® trademarks of their respective holders. Use of them does not imply any affiliation with or endorsement by them.

TABLE OF CONTENTS

INTRODUCTION6
 OPTIONS - SPECIAL INSTALLATIONS 6
 CONTACT US 6

SAFETY7
 INFORMATION ON SIGNAL WORDS 7
 SAFETY LABELS ON THE VEHICLE 7
 GENERAL SAFETY RECOMMENDATIONS 15
 DANGER ZONES 16
 EMERGENCY EXIT - WIDE CAB 20
 SAFETY ITEMS INSIDE THE CAB 20

RECOMMENDED USE AND PRACTICES22
 PRODUCT APPLICATION 22
 PROPER USE AND SAFETY REGULATIONS 22
 WARRANTY COVERAGE 22
 QUALIFICATION OF DRIVERS 22
 QUALIFICATION OF SERVICE PERSONNEL 23
 MAINTENANCE 23
 PARTS, ACCESSORIES AND MODIFICATIONS 23
 PAYLOAD 23
 DUMP BODY MODIFICATION AND USE 23
 CE MARKING 23
 IDENTIFICATION LABELS 24
 DIRECTION DESIGNATION 25
 VEHICLE MAIN COMPONENTS 26

STEERING COLUMN, PEDAL AND ARM REST CONTROLS27
 STEERING WHEEL 27
 IGNITION SWITCH AND KEY 28
 STEERING COLUMN ADJUSTMENT LEVER 28
 ACCESSORY LEVER 29
 SPEED PEDAL 29
 TRANSMISSION LEVER 30
 JOYSTICK 30

LATERAL CONSOLE33
 LCD DISPLAY 33
 EMERGENCY STOP SWITCH 33
 ENGINE SPEED CONTROL KNOB 34
 HEATER CONTROL KNOBS 34
 SWITCHES FOR EQUIPMENT AND OPTIONS 35
 AIR CONDITIONING SWITCH 35
 INVERSION SWITCH 35
 JOYSTICK ON/OFF SWITCH 36
 CONNECTORS 36
 AUDIBLE SIGNAL BUZZER 37
 POWER SUPPLY OUTLETS 37
 STORAGE COMPARTMENT 37
 PRE-HEATER CONTROL UNIT 38

LCD DISPLAY 41
 MAIN SCREEN 41
 LED INDICATORS 41
 MAIN SCREEN INDICATIONS 42
 NAVIGATING 46

OVERHEAD CONSOLE 56
 RADIO UNIT 56
 MONITOR FOR THE REAR VIEW CAMERAS 56
 LIGHT SWITCHES 57
 REAR WIPER SWITCH 57

COMPONENTS INSIDE THE CAB 58
 KEY 58
 DOOR 58
 LEFT LATERAL WINDOW 60
 RIGHT SIDE FRONT WINDOW 60
 CAB STORAGE NET 60
 DOME LIGHT 60
 CAB AIR VENTS AND GRILL 61
 TILT SENSOR 61
 DRIVER SEAT 62
 SEAT BELTS 64
 LEFT SIDE ARM REST 65
 FIRE EXTINGUISHER 65
 CAB ACCESSORIES 65
 FIRST AID KIT 66
 ESCAPE SYSTEM 66
 MANUALS, TOOLS AND ACCESSORIES 66
 EMERGENCY DRIVE MODULE 67

COMPONENTS OUTSIDE THE CAB 68
 BATTERY ISOLATOR SWITCH 68
 TRACK TENSION RELEASE KNOBS 68
 FUEL FILLER CAP AND TANK 69
 DEF/ADBLUE® FILLER CAP 71
 WATER SEPARATOR DRAIN VALVE 71
 HEATER CONNECTOR 71
 FUEL HEATER 72
 WINDSHIELD WASHER FLUID RESERVOIR 73
 HYDRAULIC OIL LEVEL SIGHT GLASS 73
 EXTERIOR MIRRORS 73
 REAR VIEW CAMERAS 73
 ROOF GRILL (FOPS) 74
 BRUSH GUARD 74
 DUMP BODY 75
 COWLING ACCESS PANELS AND OPENINGS 75
 STEPS AND GRAB HANDLES 77
 BEACON LIGHT 78
 "D" RINGS 78
 LUBRICATION PORTS 78
 DRAINING HOSE FOR HYDROSTATIC TANK 78

TABLE OF CONTENTS

PRE-OPERATION INSPECTION	79	RIDING ON ROUGH OR HAZARDOUS GROUNDS.....	102
INSPECTION BEFORE STARTING THE ENGINE	79	CROSSING IN SHALLOW WATER	102
ENGINE OIL LEVEL	79	CENTER OF GRAVITY OF EMPTY VEHICLE	103
ENGINE COOLANT LEVEL.....	79	FRONT COUNTERWEIGHT.....	103
HYDROSTATIC OIL LEVEL	80	LOADING AND UNLOADING VEHICLE ON RAMPS	104
FUEL FILTER / WATER SEPARATOR.....	80	OVERSPEED ON DOWNHILL SLOPES	104
PUMP DRIVE OIL LEVEL.....	81	ANTI-STALL	104
PLANETARY GEARBOXES OIL LEVEL	82	SPECIAL SITUATIONS.....	105
WINDSHIELD WASHER FLUID LEVEL	82	DUMP BODY OPERATION	106
TRACK AND UNDERCARRIAGE CONDITION.....	83	OVERVIEW	106
OIL LEVEL IN WHEEL HUBS AND ROLLER HUBS.....	84	SAFETY ROD	111
LUBRICATION.....	84	DUMP BODY MODIFICATION AND USE	112
WALK AROUND CHECK.....	84	SAFETY CHECK LIST	113
SAFETY EQUIPMENT.....	84	TECHNICAL DATA	114
SAFE WORK ENVIRONMENT	84	VEHICLE SPECIFICATIONS	114
INSPECTION AFTER ENGINE START	85	DIMENSIONS.....	118
FUEL LEVEL.....	85	RETRIEVAL POINT	119
DEF/ADBLUE® LEVEL.....	85	JACKING POINTS	119
HYDROSTATIC OIL LEVEL	85	TRANSPORT PREPARATION.....	120
BACKUP ALARM AND PARK BRAKE VERIFICATION	85	GENERAL MAINTENANCE GUIDELINES ...	121
TRACK TENSION	86	INTRODUCTION.....	121
CLOGGED FILTER INDICATOR.....	86	SAFETY	121
ENGINE STARTING AND SHUTDOWN.....	87	HOW TO WASH AND CLEAN THE VEHICLE	122
STARTING THE ENGINE	87	ENGINE AND SYSTEM MAINTENANCE	123
SHUTTING DOWN THE ENGINE	89	AFTERTREATMENT AND REGENERATION	123
DRIVING INSTRUCTIONS.....	90	ENGINE OIL.....	126
SETTING THE VEHICLE IN MOTION	90	OIL AND FILTER CHANGE PROCEDURE	127
FORWARD MOTION	91	CHANGING THE ENGINE COOLANT.....	129
REVERSE MOTION.....	92	CHANGING THE FUEL FILTERS.....	131
SWINGING.....	93	DRAINING THE FUEL TANKS.....	133
STEERING WHEEL HANDLING	94	FUEL SYSTEM VERIFICATION	133
AUTO-BRAKE.....	94	REPLACING THE CRANKCASE BREATHER FILTER	
OIL TEMPERATURE AND DRIVE SYSTEM.....	94	CARTRIDGE	134
OIL TEMPERATURE AND SWING SYSTEM.....	96	REPLACING THE ENGINE AIR FILTER	135
SLOWING DOWN AND BRAKING	97	CLOGGED AIR FILTER INDICATOR	135
PARKING BRAKE.....	97	INSPECTING THE COOLING SYSTEM.....	136
PARKING THE VEHICLE.....	97	INSPECTING THE ENGINE DRIVE BELT	136
DRIVING A PARTIALLY DISABLED VEHICLE	98	DRIVE SYSTEM MAINTENANCE	137
ADVANCED GUIDELINES FOR DRIVING	99	CHANGING THE OIL OF THE PUMP DRIVE	137
LOSS OF CONTROL OF THE VEHICLE.....	99	HYDROSTATIC OIL.....	137
OFF-HIGHWAY OPERATION	99	CHANGING THE OIL OF THE PLANETARIES	138
GENERAL SAFETY PRECAUTIONS.....	99	CHANGING THE OIL OF THE WHEEL HUBS	138
GUIDELINES FOR VEHICLE GRADEABILITY LIMIT	99	CHANGING THE OIL OF THE TOP ROLLER HUBS	139
UPHILL DRIVING.....	100	PARKING BRAKE VERIFICATION	140
DOWNHILL DRIVING	100	TOWING	141
SIDE HILL DRIVING	101	TRACK TENSION VERIFICATION.....	143
DROP-OFFS.....	101	WHEEL WEAR VERIFICATION AND WHEEL	
TRACK TENSION	101	PERMUTATION	143
DETRACKING.....	101	VERIFICATION OF THE TORQUE	144
ROTATION BRAKE	101	TIPS FOR TRACK REMOVAL AND INSTALLATION	145
ICE HAZARD	102		

ELECTRIC SYSTEM MAINTENANCE..... 146

ACCESSING THE CAB ELECTRICAL BOX 146

REPLACING A FUSE IN THE CAB..... 146

REPLACING THE FUSE OF THE CAB HEATER 148

REPLACING A FUSE ON THE BATTERY SUPPORT ... 148

BATTERY MAINTENANCE 149

ELECTRIC COMPONENTS AND WATER..... 150

CAB AND FRAME MAINTENANCE 151

UPPER STRUCTURE SWINGING SYSTEM..... 151

CAB STRUCTURAL INTEGRITY / ROPS..... 155

USING THE THREADED HOLES ON CAB TOP 155

CHECKING FRAME STRUCTURAL INTEGRITY 155

PRECAUTIONS AGAINST SALT WATER AND
CORROSION 155

WELDING 155

RELEASING HYDRAULIC PRESSURE..... 155

REPLACEMENT OF HOSES AND FITTINGS 156

CONNECTING AND DISCONNECTING HYDRAULIC
HOSES 156

REPLACING LIGHT BULBS..... 156

REPLACING THE CAB AIR FILTERS..... 159

FRONT AND REAR WIPER INSPECTION 160

CHANGING A WIPER BLADE 160

MISCELLANEOUS MAINTENANCE 161

USING THE EMERGENCY DRIVE MODULE..... 161

DUMP BODY MAINTENANCE AND INSPECTION 163

AIR CONDITIONING MAINTENANCE 163

LUBRICATION 164

BASIC TROUBLESHOOTING..... 165

FASTENER TORQUE CHART 167

DAILY AND WEEKLY OPERATOR VERIFICATION
SCHEDULE 169

SEVERE SERVICE APPLICATION..... 170

ENGINE OPERATING HOURS..... 170

MAINTENANCE SCHEDULE 171

BREAK-IN AND STORAGE GUIDELINES..... 173

DISPOSAL..... 174

HAZARDOUS MATERIAL 174

COLLECT, PACKAGE AND LABEL 174

SHIPPING OF WASTE 174

SCRAPPING 174

DECLARATION OF CONFORMITY..... 175

LIST OF ABBREVIATIONS..... 176

INDEX..... 177

INTRODUCTION

INTRODUCTION

This Operating and Maintenance Manual is intended to help you to become familiar with the numerous performance and safety features of the vehicle.

Proper operation and meticulous care are essential to maintain the vehicle in top condition with minimal downtime. This instruction manual is an integral part of the vehicle. It promotes the best and safest way to use the product.

The instructions have been written on the basis that the vehicle is to be used as an off-road dumper. Other use of the vehicle could require additional instructions/precautions not available in this manual.

Ensure this Operating and Maintenance Manual remains in the cab at all times as it is an important part of the vehicle. Replacement manuals are available through the Parts Department.

Refer to the last section of this manual for a list and description of the abbreviations used throughout the text.

OPTIONS - SPECIAL INSTALLATIONS

Some items or components shown in this manual may be optional or installed only on vehicles intended for specific countries or regions.

CONTACT US

To help you get your vehicle up and running or to help you find your local distributor, call the After-sales Product support.

In Europe, Russia, Turkey and Africa, please call:

+43-5262-62121-3120

In North America, South America, Asia Pacific, please call:

1 450 776-3663

PRINOTH Website

Consult our website at prinoth.com or contact us at: utilityvehicles@prinoth.com

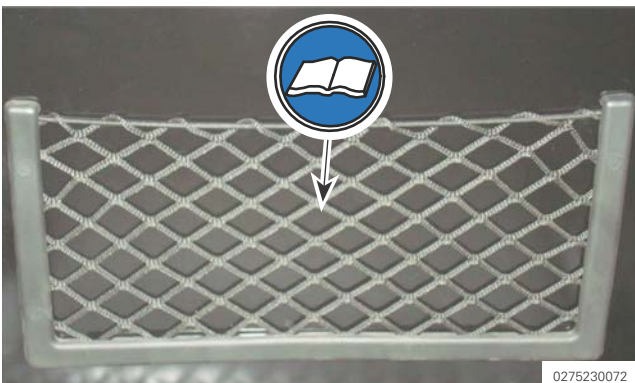
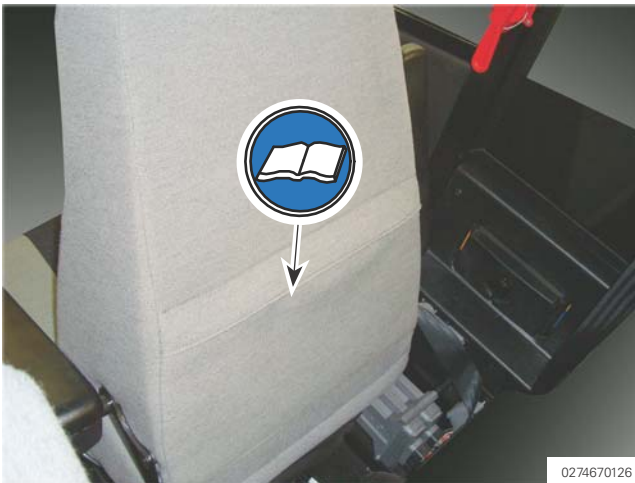

Figure 1
Operating and Maintenance Manual - possible locations

SAFETY

Safety messages are incorporated in the present manual and on labels placed directly on the vehicle.

MESSAGES IN THE MANUAL

The safety messages contained in the present operating and maintenance manual are structured as follows:

NOTE : The safety information is based on the ANSI Z535 series of standards.

SIGNAL WORD

Naming of risk

Naming of possible consequences

Naming of avoidance options

Example:

⚠ WARNING

Explosion hazard

Fumes from refuelling could ignite and cause severe injuries or burns. Always switch off the heater BEFORE refuelling the vehicle.

INFORMATION ON SIGNAL WORDS

Signal word or icon	Description
	The general danger symbol warns of serious injury when used with the signal words CAUTION, WARNING and DANGER. Follow all instructions to avoid injuries or death.
NOTICE	Indicates a situation that may result in damage or destruction of a component or system.
CAUTION	Indicates a potentially hazardous situation which, if not avoided, may result in minor or moderate injury.
WARNING	Indicates a potentially hazardous situation which, if not avoided, may result in death or serious injury.
DANGER	Indicates an immediate hazardous situation which, if not avoided, will result in death or serious injury.

ENVIRONMENTAL PROTECTION

Indicates information in the area of environmental management.

SAFETY LABELS ON THE VEHICLE

Some stickers on the vehicle carry the same information as the safety messages in the manual and incorporate pictograms to add a visual component to the message. Each pictogram contains three types of information: shape, colour and symbol.

NOTE : The information on the vehicle (stickers) incorporates ANSI Z535 standard format and pictograms based on the ISO 3864 standards.

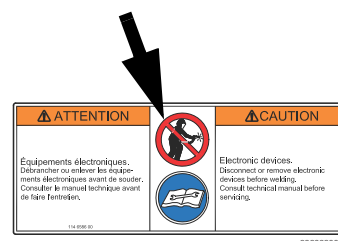

The pictograms indicate:

- » **a risk:** an exclamation mark inside a black triangle on a yellow background (shown here is the general safety alert pictogram);



- » **an interdiction:** an icon inside a red circular band and a 45° diagonal red band from upper left to lower right on a white background (shown here is the "avoid contact between posts" pictogram);



- » **a command:** an icon inside a circle with a blue background (shown here is the "consult the manual" pictogram).







SAFETY

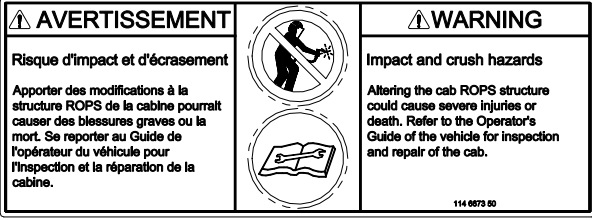
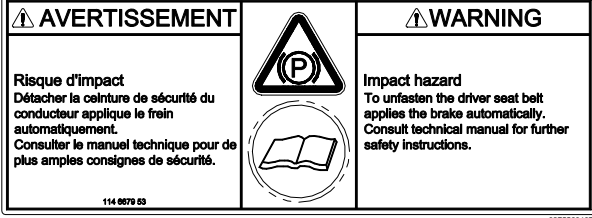
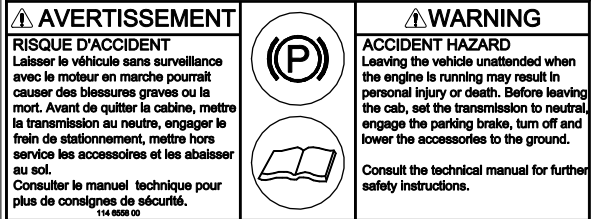
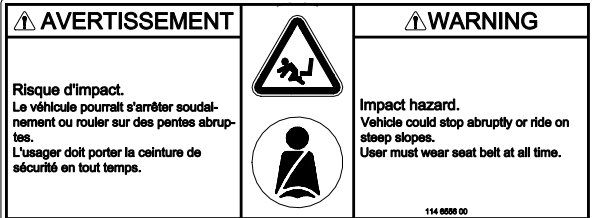
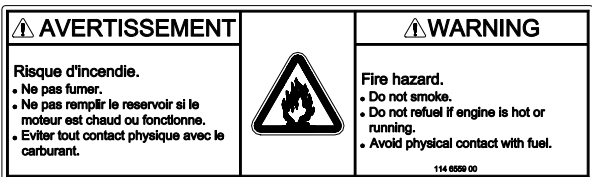

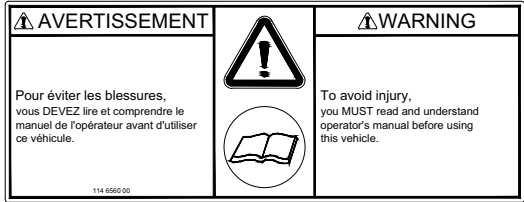

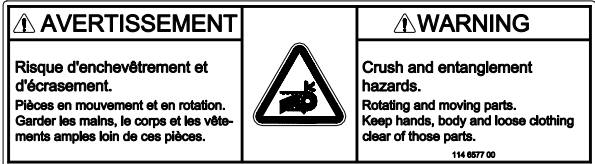
Message of Important Labels

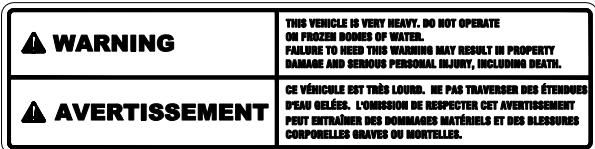
This section provides the content of each of important label installed on the vehicle. Use this information to replace any damaged or missing label. Use the next section for location

Description	Label
<p>Risk of impact or crushing Alteration of the ROPS structure could lead to severe injuries or death. Refer to the Operator's Guide of the vehicle for complete information.</p>	
<p>Risk of impact Unbuckling the safety belt of the driver will automatically apply the parking/emergency brake. Refer to the Operator's Guide of the vehicle for complete information.</p>	
<p>Risk of accident Leaving the vehicle unattended when the engine is running could result in personal injuries or cause an accident. Refer to the Operator's Guide of the vehicle for complete information.</p>	
<p>Risk of impact The driver must wear the seat safety belt at all times when driving the vehicle.</p>	
<p>Fire hazard Do not smoke, do not refuel if engine is warm or running, avoid physical contact with fuel.</p>	

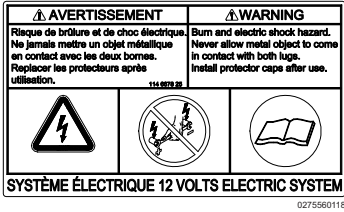
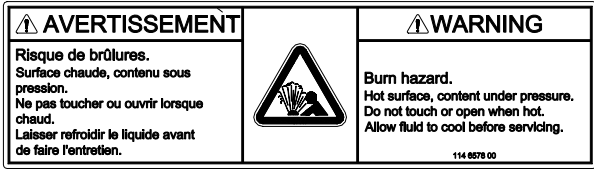
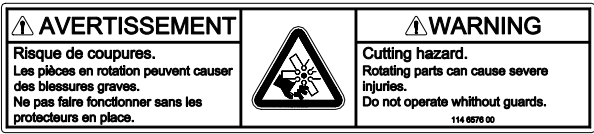
Description	Label
<p>To avoid injuries One must read and understand the operator's manual before driving the vehicle. The manual contains important safety information and guidelines for safe and efficient use of the vehicle.</p>	 <p style="text-align: right; font-size: small;">0275560111</p>
<p>Risk of falling, crushing and cutting Always ride inside the cab. Allow no passenger on the vehicle.</p>	 <p style="text-align: right; font-size: small;">0275560112</p>
<p>Risk of crushing and entanglement Keep clear from rotating and moving parts. Do not wear loose clothing.</p>	 <p style="text-align: right; font-size: small;">0275560113</p>
<p>Hot surface hazard Some surfaces could be hot, allow the surfaces to cool before performing maintenance.</p>	 <p style="text-align: right; font-size: small;">0275560116</p>
<p>Risk of drowning The vehicle is very heavy. Do not drive over frozen body of water.</p>	 <p style="text-align: right; font-size: small;">0275560117</p>

SAFETY

Description	Label
<p>Risk of severe burn and electric shock Never allow metal objects to contact both battery lugs or boosting lugs. Install caps or protectors on lugs when not in use.</p>	
<p>Risk of severe burn Hot surface, content under pressure. Do not open when hot, do not touch. Allow fluid to cool before performing maintenance.</p>	
<p>Cutting hazard Rotating parts could cause severe injuries. Do not operate without guards / do not place body parts near rotating fan.</p>	
<p>Impact and crush hazard Rotating structure could cause severe injuries or death. Keep off swing area.</p>	
<p>Risk of burn Hot surface. Do not touch when hot. Allow to cool before opening or use protective gloves.</p>	
<p>Emergency Exit Open window or break glass with hammer</p>	

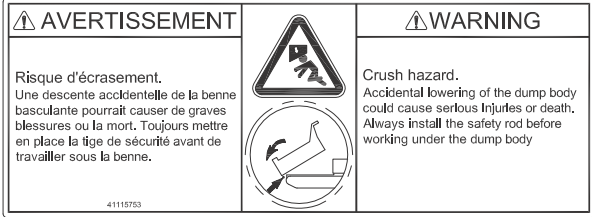
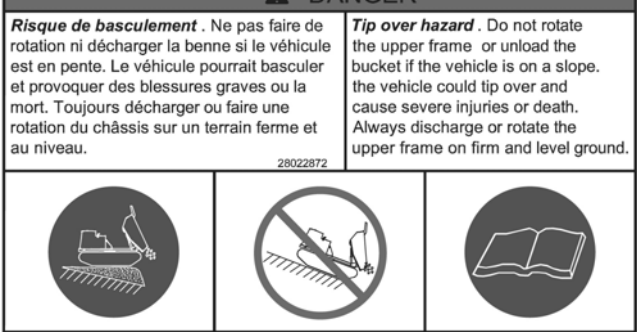
Description	Label
<p>Crush hazard Accidental lowering of the dump body could cause serious injury or death. Always install the safety rod before working under the dump body.</p>	
<p>Tip over hazard Avoid rotating the upper frame or discharging the load on a slope. The vehicle could lose its balance and tip over.</p>	

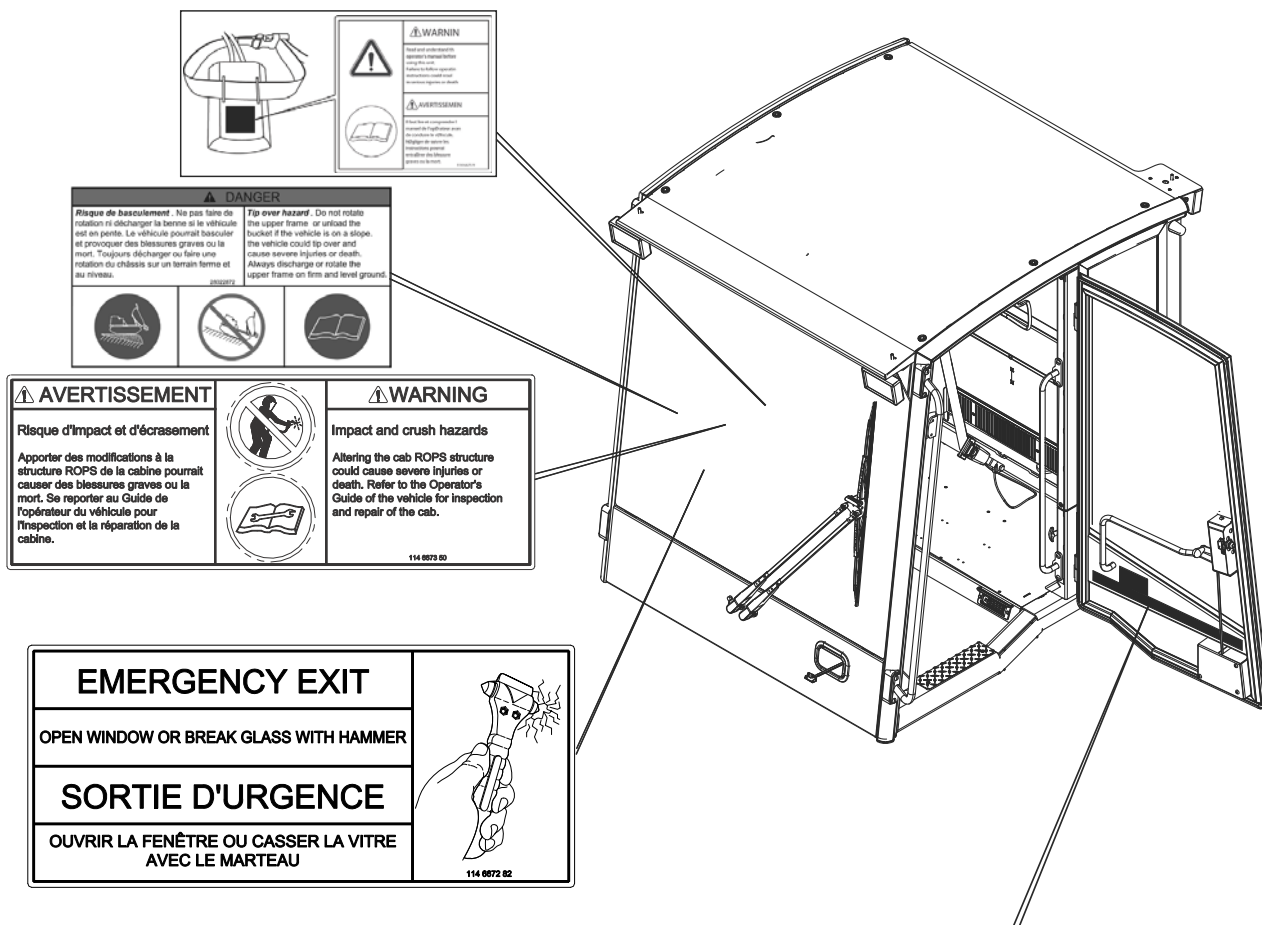

⚠ AVERTISSEMENT	(P)	⚠ WARNING
Ne pas quitter le véhicule sans appliquer le frein et abaisser les accessoires au sol. Consulter le manuel technique pour de plus amples consignes de sécurité.		Do not leave vehicle without applying the parking brake and lowering the implements to the ground. Consult technical manual for further safety instructions.
114 6558 00		

⚠ AVERTISSEMENT		⚠ WARNING
Pour éviter les blessures, vous DEVEZ lire et comprendre le manuel de l'opérateur avant d'utiliser ce véhicule.		To avoid injury, you MUST read and understand operator's manual before using this vehicle.
114 6560 00		

⚠ AVERTISSEMENT		⚠ WARNING
Risque d'impact. Le véhicule pourrait s'arrêter soudainement ou rouler sur des pentes abruptes. L'utilisateur doit porter la ceinture de sécurité en tout temps.		Impact hazard. Vehicle could stop abruptly or ride on steep slopes. User must wear seat belt at all time.
114 6556 00		

⚠ AVERTISSEMENT		⚠ WARNING
Risque d'impact. Détacher la ceinture de sécurité du conducteur applique le frein automatiquement. Consulter le manuel technique pour de plus amples consignes de sécurité.		Impact hazard. To unfasten the driver seat belt applies the brake automatically. Consult technical manual for further safety instructions.
114 6679 00		

0275640050

Figure 3

SAFETY

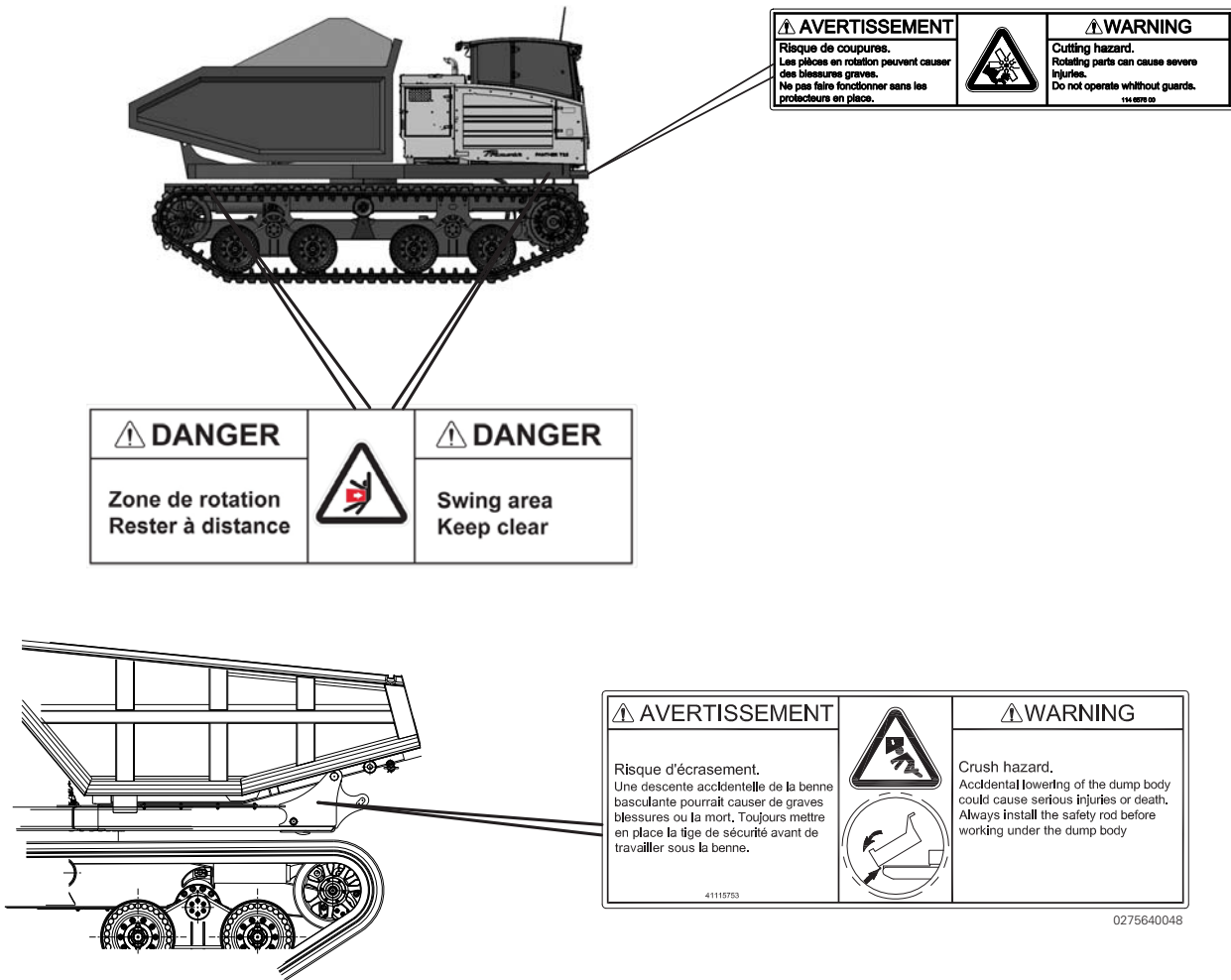

1105340027

Figure 4

GENERAL SAFETY RECOMMENDATIONS

⚠ WARNING

Failure to observe the warnings and follow instructions on the vehicle may result in serious injury including death to the operator and/or bystanders.

Read and understand all of the safety precautions and warnings in this manual before performing operation or maintenance. The following list contains the general safety precautions that must be followed to provide personal safety. Special safety precautions are included in the procedures when they apply.

This manual is indispensable for the proper use of the vehicle, and should be kept with the vehicle at all times.

If the vehicle is equipped with a special device, read and understand all of the safety precautions and warnings in the manual of the equipment manufacturer before performing operation or maintenance.

The following guidelines may help minimize hazards associated with the use of tracked vehicles. Not all situations may apply since vehicle operation and configuration as well as topography vary considerably.

Operation

- ⚠ Visually inspect vehicle and check function of all lighting equipment before operation.
- ⚠ Operator, and passenger if applicable, must be completely within cab while vehicle is operating.
- ⚠ The vehicle is designed for one person per seat inside the cab. No other passenger should be carried by the vehicle.
- ⚠ Driver should have sufficient rest periods to remain alert and focused while operating.
- ⚠ Sound volume of the radio should be kept low to ensure operator hears audible signals or other noises to stay aware of the work environment.
- ⚠ Do not operate vehicle when bystanders are in the vicinity.
- ⚠ Never operate the vehicle except from operator's seat.
- ⚠ Never bypass safety features. Never fasten the seat belt directly on the seat to avoid wearing it.
- ⚠ Driver or passenger must not jump out of the vehicle unless it has performed a complete stop and brake is applied.
- ⚠ Maintain good visibility at all times. Keep windows and mirrors clean, ensure windshield washer fluid is available.
- ⚠ Operate at moderate speed. Avoid harsh and abusive operation.
- ⚠ Always back-up the vehicle at walking speed to compensate for reduced visibility.
- ⚠ Do not operate vehicle and equipment beyond its rated capacity.
- ⚠ Avoid sharp turns whenever possible.
- ⚠ Never leave engine running while vehicle is unattended. Shut off engine and remove key when leaving vehicle.
- ⚠ The vehicle is heavy. Do not operate on frozen bodies of water.
- ⚠ Bush or snow-covered terrain could conceal dangerous obstacles. Proceed slowly and with caution.
- ⚠ Unless vehicle can safely descend as well as ascend a slope, or an alternate descent path is known, do not attempt a climb.
- ⚠ Small obstacles on steep slopes should always be considered a hazard.

Swinging the vehicle upper frame

- ⚠ The upper section of the vehicle will extend beyond the track width when swinging. Always check that the surrounding area is clear before swinging the upper section of the vehicle.
- ⚠ Check the inverted configuration icon and LED before setting the vehicle in motion. The transmission lever and steering wheel operation could be inverted.
- ⚠ Check the alignment indicator icon before setting the vehicle in motion. It indicates that the upper structure of the vehicle is aligned, or not aligned, with the tracks.
- ⚠ Always raise the armrest when entering or leaving the cab, to disable the joystick and prevent unwanted manoeuvres. It is NOT possible to drive the vehicle when the armrest is raised.
- ⚠ Turn off the joystick switch to prevent unwanted manoeuvres. It is NOT possible to rotate the vehicle and move the dump body when the switch is off.
- ⚠ If installed, use the cameras and the monitor to improve precision and safety.
- ⚠ Before turning off the engine, it is recommended (not mandatory) to align the vehicle in the normal configuration if it is possible/safe. It permits to use the step when leaving the cab and start the vehicle in the normal configuration for the next driver.

Dump body operation

- ⚠ Always dump the load of the dump body on a flat, level and stable ground.

SAFETY

DANGER ZONES

The area around the vehicle is divided into various danger zones. The figure below shows the danger zones while the table indicates the dangers existing in the individual zones. Equipment by third party installer is not covered in the table. Some of the components referred to are optional.

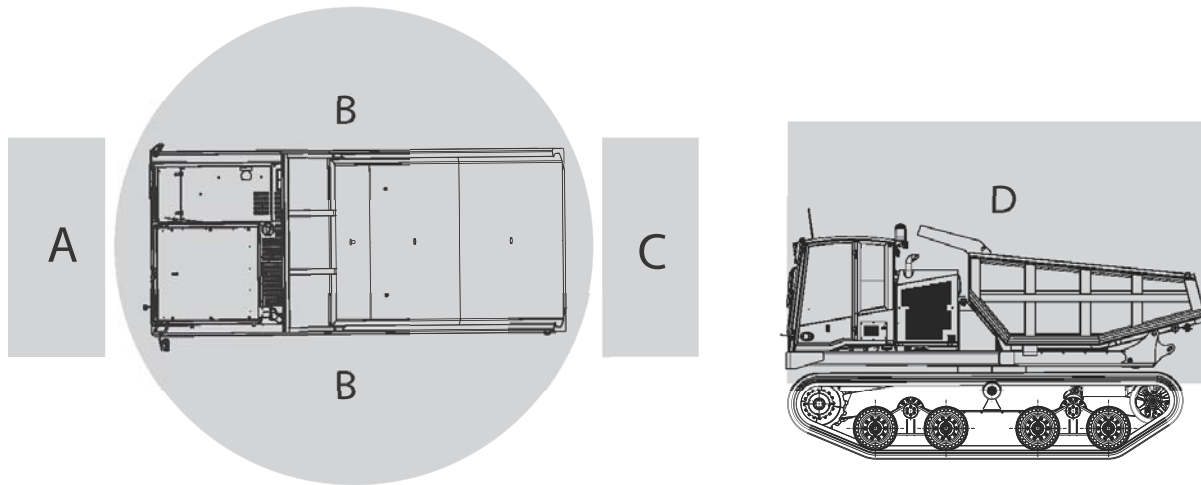

0275640115

Figure 5
 A: Front
 B: Sides and/or bottom
 C: Rear
 D: Top

TYPE OF DANGER	ZONE				ACTIVITY			
	A	B	C	D	Operation	Cleaning	Maintenance	Disposal
Risk of crushing								
Falling / swinging engine access panel		X		X		X	X	
Opening / closing cab door		X			X	X	X	
Crushed under tracks	X	X	X		X		X	
Crushed under dump body (option)		X	X	X	X	X	X	
Hitting interior cab surfaces (e.g. seat belt not fastened)	inside cab				X			
Hit by unfasten objects in the cab	inside cab				X			
Being hit by something while driving with the door "latched-open"	inside cab				X			
Crushed or pinched while the track tensioner piston extends		X	X				X	
Hit by the upper frame of the vehicle when swinging	X	X	X		X		X	

TYPE OF DANGER	ZONE				ACTIVITY			
	A	B	C	D	Operation	Cleaning	Maintenance	Disposal
Risk of cut and amputation								
Cooling fans		X					X	
Risk of entanglement								
Tracks (undercarriage)	X	X	X		X		X	
Engine drive belt		X					X	
Risk of collision								
Emergency drive module lack of precision	X	X	X		X		X	
Vehicle in inverted configuration, inverted transmission controls	X	X	X		X		X	
Engine stop (various reasons / failures)	X	X	X		X		X	
Detracking	X	X	X		X			
Brake failure / worn brake discs	X	X	X		X		X	
Disengaged planetary gearboxes	X	X	X		X		X	
Tipping of vehicle	X	X	X		X			
Skidding of vehicle	X	X	X		X			
Running over people / personnel	X	X	X		X		X	
Electronic microcontroller (or related component) failure	X	X	X		X			
Swinging of upper frame	X	X	X		X			
Risk of ejection of solid/liquid material								
From bulk material falling from dump body (option)			X		X	X		
Risk of ejection of fluid under pressure								
From hydraulic hoses, fittings or connectors	X	X	X	X	X		X	
Risk of slipping								
Climbing to the cab		X			X	X	X	X
Climbing to the frame or on equipment (slipping on slippery surface)	X	X	X	X	X	X	X	X
Risk of contact with power lines / cables								
When using cables to jump start the vehicle		X	X	X	X		X	
Raised dump body (option) comes in contact with power lines				X	X	X	X	
Risk of burn / splash from melted material								
When using cables to jump start the vehicle	X	X			X		X	

SAFETY

TYPE OF DANGER	ZONE				ACTIVITY			
	A	B	C	D	Operation	Cleaning	Maintenance	Disposal
Risk of permanent hearing damage								
Through noise from vehicle (long exposure to moderate noises)		inside cab			X			
Through noise from vehicle (short exposure to loud noises)		outside cab					X	
Risk to health from vibration								
Through vibration from the driver/passenger seat		inside cab			X			
Risk of burn and scalding								
Contact with the engine or sub-system components		X		X		X	X	
Contact with the muffler or exhaust pipe (or aftertreatment system)		X		X		X	X	
Contact with hot halogen lights	X			X		X	X	
Contact or splash with hot hydraulic oil, engine coolant or heating/ventilation/AC fluid		X	X	X			X	
Risk of burn and poison								
Exhaust fumes entering the cab		inside cab			X		X	
Exhaust fumes from the diesel engine (outside the cab)		outside cab			X		X	
Gases escaping from broken halogen lights	X			X			X	
Contact with battery gases / acids	X	X					X	
Contact with hydraulic oil		X	X				X	
Contact with fuel (or DEF/AdBlue®)		X			X		X	
Risk of fire or explosion								
Fire in the cab		inside cab			X		X	
Ignition of fuel during refuelling		X			X			
Explosion of battery gases	X	X			X		X	
Explosion of halogen lights	X			X	X		X	
Risk to health from physiological effects								
Controls layout unsuitable for operator physique					X			
Seat unsuitable for operator physique					X			
Continuous operating hours too long					X			

TYPE OF DANGER	ZONE				ACTIVITY			
	A	B	C	D	Operation	Cleaning	Maintenance	Disposal
Risk to health from psycho-physiological								
Visibility problems in the work area (blind spots, glare, darkness, etc.)					X			
Health problems from ergonomic issues					X			
Risk of human errors								
Driving in area or terrain not suitable for vehicle					X			
Unauthorized use of the vehicle and equipment					X			
Lack of training or faulty operation					X			
Operating while personnel are in the danger zone of the veh. or equipment					X			
Faulty maintenance					X			
Risks of polluting the environment								
Loss of fuel or spilling of fuel while refuelling or from water separator		X			X		X	
Loss of hydraulic oil (planetaries, hubs, hoses, fittings)		X			X		X	
Loss of coolant from the engine		X			X		X	
Harmful emission from the engine		X			X		X	
Loss of refrigerant gas from air conditioning circuit		X					X	
Spilling battery acid		X					X	X
Loss of oil filter / fuel filter		X					X	X
Spilling oil / fuel / DEF-AdBlue® / lubricant / coolant out of their canister					X		X	X
Not collecting water when washing components						X	X	

SAFETY

EMERGENCY EXIT - WIDE CAB

If the door becomes unusable, the alternate way is to break the side window with the escape tool and exit through the opening.

Using the Emergency Exit with the Escape Tool

If the cab door cannot be opened, exit the cab by breaking the side window :

NOTE : The windshield (front glass) is laminated and holds together even when shattered. The escape tool is not designed to be used on this glass surface.

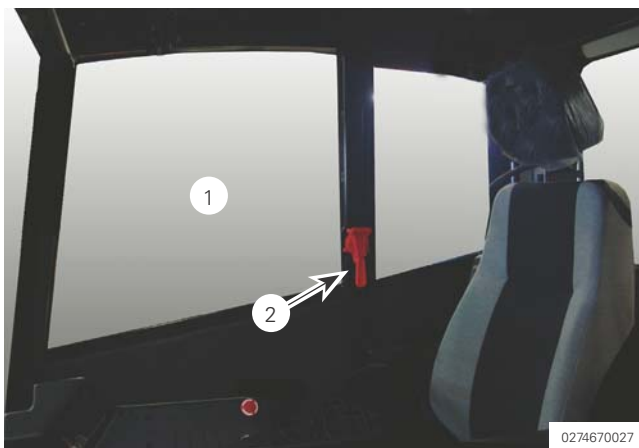

Figure 6

1. Right side window emergency exit
2. Escape tool on right side window pillar

Use the escape tool to break the glass:

- » Look for the bright orange handle. It is located on the vertical post between the right side windows inside the cab.
- » Pick up the tool from its support bracket and hold the tool by the handle, with the hammer head pointing up.
- » Shield eyes (or wear safety glasses) and face and smash the window by swinging the tool overhand, like a household hammer. One or two strikes should shatter the glass. Any of the two heads of the hammer can be used for this purpose.
- » Using the surface between the two heads of the tool, scrape the remaining glass from the window edges.
- » If not already done, unbuckle the seat belt.
- » Exit the cab through the opening.

NOTE : Unbuckling the driver's seat belt will bring the vehicle to a complete stop but opening the door alone will not.

SAFETY ITEMS INSIDE THE CAB

Ensure all items are located in the cab and are in good condition and ready to be used. Refer to the previous section for instructions on how to use the escape tool/system.

Escape Tool

The escape tool is located in the cab. Ensure it is in good condition and ready to be used.

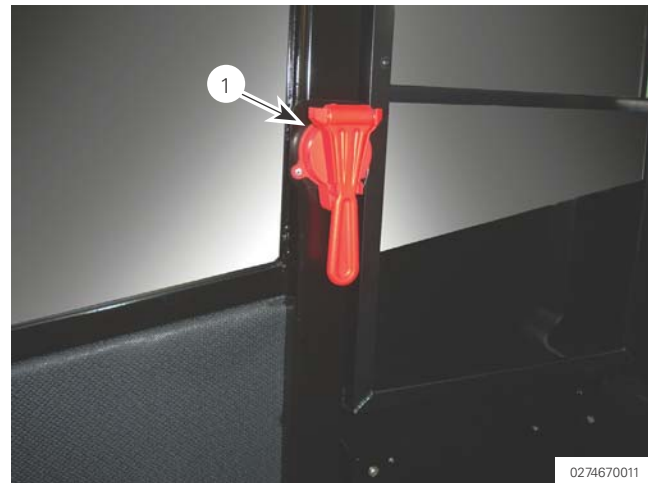

Figure 7

1. Escape tool

First Aid Kit



Figure 8

First aid kit (may differ from picture)

A first aid kit is located in the cab. Use as required. Ensure the kit is good condition (inspect yearly) and refurbished after each use.

Fire Extinguisher



Figure 9

Fire extinguisher (may differ from picture)

A fire extinguisher is located on the floor at the left of the operator's seat in the cab. Ensure that extinguisher is full and ready to be used before starting engine.

Do not place objects on or near the extinguisher so it remains easy to reach at all times.

Agitate the fire extinguisher vigorously to loosen caked chemical compound at regular intervals.

If replacing the unit, use one of the same type.

Additionally:

- » If equipped, ensure the pressure indicator shows the extinguisher is ready and operational. If not, have the extinguisher checked and refill by experts;
- » Have the extinguisher checked by experts every year to ensure proper operation;
- » Extinguisher must be refilled after each use by a certified facility;
- » Ensure extinguisher is held firmly in place while the vehicle operates.

NOTE : The extinguisher has to be replenished after each use. Always have the unit sent to a certified fire equipment dealer or service company. An annual inspection is recommended.

Seat Belt



Figure 10

Seat belt latch

The seat belt system is a crucial component for the safety of the driver (and passenger if applicable).

Refer to the "COMPONENTS INSIDE THE CAB" section for full details on this item.

NOTE : The seat, seat belt and cab have to be inspected and returned to factory specifications in case of an accident. A replacement may be required. An annual inspection is recommended.

ROPS and FOPS Cab (option)

NOTE : ROPS (Roll Over Protective Structure), FOPS (Falling Object Protective Structure).

A cab in compliance with ROPS and/or FOPS standards is available as an option or with specific vehicle configurations. This type of cab has to be ordered and installed at the PRINOTH factory on a new vehicle.

When the certification is effective, it does NOT exempt the operator (and passenger if applicable) from wearing the seat belt.

ROPS

In areas where terrain or manoeuvres poses rollover hazards.

FOPS

In areas where objects falling on the roof of the cab pose hazards.

RECOMMENDED USE AND PRACTICES

RECOMMENDED USE AND PRACTICES

PRODUCT APPLICATION

The vehicle is designed to be used as a crawler dumper with a rotating upper structure. In this application, the vehicle is equipped with a dump body and carries bulk material (mainly soil) on construction sites.

Any other application not in line with the above has to be approved in writing by PRINOTH.

This all-terrain carrier is designed for rough terrain and off-road work in all seasons. With the appropriate options selected and genuine PRINOTH parts installed at the factory, the cab complies with R.O.P.S. standards (ISO 3471: 2008, table 1, section 1) or with the F.O.P.S. standard (ISO 3449: 2005, level II), or both.

The vehicle and its accessories are only to be used for off-road driving and are not approved for use on public roads.

The vehicle may only be operated in accordance with the operating and maintenance instructions.

The vehicle and its equipment can represent a threat to the user and/or third party. **The user has to determine whether special hazards exist in his application and take the required safety precautions.** Only qualified persons are allowed to drive and use.

Operating a dump body may present specific dangers. Refer to the dedicated section in this manual. Read and understand all safety precautions prior to operation.

NOTE : PRINOTH reserves the right to make changes in design and specifications and/or to make additions to, or improvements in its products without any obligation to install them on previously manufactured vehicles.

PROPER USE AND SAFETY REGULATIONS

Use of the vehicle and its accessories require compliance with all instructions for use and safety regulations formulated by PRINOTH in the present manual.

In addition to the operating instructions, compliance is also required with the general legal requirements relating to accident prevention and environmental protection in each country. That also applies to the provision of wearing of personal protective equipment.

The operating and maintenance manual must be kept for the whole service life of the vehicle and be available to drivers and service personnel at any time.

WARRANTY COVERAGE

Genuine spare parts and special accessories have been produced for the vehicle. The vehicle components are tested to ensure reliability, operational security and efficiency of the vehicle.

Spare parts and accessories not supplied by PRINOTH can adversely affect the operational security and reliability of the vehicle. Warranty claims will only be recognized if PRINOTH's genuine spare parts and genuine accessories are used exclusively.

Any warranty obligations lapse in the following cases:

- » failure to carry out prescribed maintenance work;
- » absence of completed control sheets or maintenance records;
- » damage or breakdowns that are not due to the service work or settings authorized by PRINOTH;
- » installation of non-approved components as well as the use of third party spare parts;
- » installation of components that will set the vehicle outside of the recommended specifications (noise, C.G. location, payload, gradeability, etc.);
- » any use of the vehicle other than the one recommended by PRINOTH (unless a written approval is obtained from PRINOTH).

The limited warranty of the vehicle is provided on a separate document, included with the vehicle at the time of original purchase.

QUALIFICATION OF DRIVERS

Only qualified persons, trained for track vehicle driving, are allowed to drive and use the vehicle.

Drivers must meet the following characteristics:

- » Have reached the age of maturity in the country where the vehicle is used (recommended);
- » Possess a valid motor vehicle driving license (recommended);
- » Be physically and mentally fit;
- » Received training on track vehicle driving and demonstrate that he/she can operate safely;
- » Have knowledge of the vehicle, its characteristics, knowledge of the terrain and the working environment. Knowledge of the risks of off-road driving. Knowledge of the applicable laws and regulations. Knowledge applicable to the activity related to the operation of the accessory installed on the vehicle.

QUALIFICATION OF SERVICE PERSONNEL

Installation, repair and some maintenance work requires the use of in-house service personnel or of service personnel trained by PRINOTH.

Technical intervention such as fault detection, diagnostic and repairs (these issues are not dealt with in the present manual) to mechanical and hydraulic as well as electrical/electronic components must only be undertaken by specialized staff who have been trained by PRINOTH.

Scrapping of the vehicle at the end of its service life must be undertaken by authorised breakers yards. Vehicle and its accessories must be disposed of in connection with relevant legal requirements.

MAINTENANCE

Maintenance work outlined in the Maintenance section may be performed by an operator with a good general knowledge of heavy equipment or machinery and standard tools. For more specialized tasks, refer to the After-sales Service of your PRINOTH distributor.

PARTS, ACCESSORIES AND MODIFICATIONS

PRINOTH does not accept liability for death, personal injury or damage that occurs if non-approved accessories are installed or non-approved modifications are made.

PAYLOAD

The maximum payload of the vehicle is 13200 Kg (29100 lb). The payload is defined as the carrying capacity of the vehicle: cargo (bulk material in the dump body).

DUMP BODY MODIFICATION AND USE

WARNING

Crush hazard

Do not attach an equipment, a device or another object in the dump body. Doing so will invalidate the ROPS certification. Carry only bulk material in the dump body.

The vehicle has been designed to transport loose material. Do not modify the dump body in any way.

CE MARKING

Refer to "DECLARATION OF CONFORMITY" on page 175 for the information on the CE marking.

RECOMMENDED USE AND PRACTICES

IDENTIFICATION LABELS

The vehicle carries two identification labels. A third label is present if a FOPS structure is installed on the top of the cab. Located in the cab, they can be found on the left side of the storage net. Refer to the next figures for the information found on the labels.

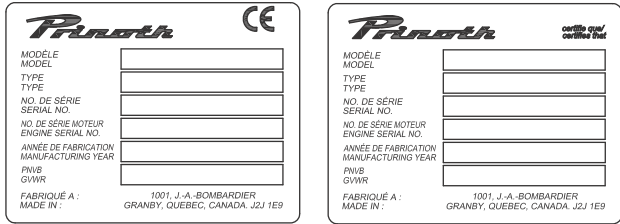

1

2

4119450012

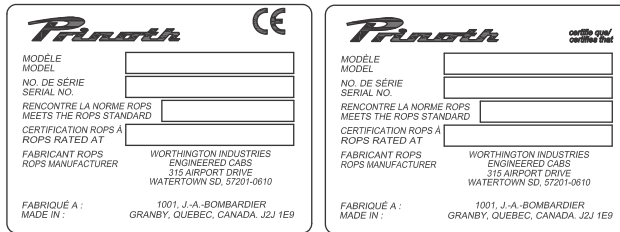

1

2

4119450013

Figure 11

Identification labels in the cab of the vehicle

1. With CE marking
2. Without CE marking

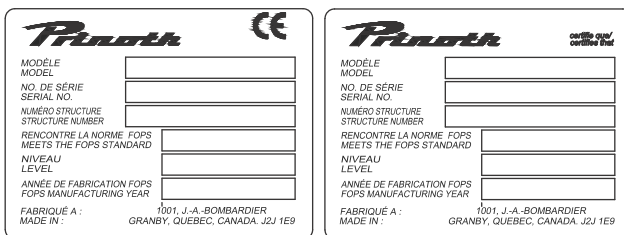

1

2

4119450014

Figure 12

Identification label dedicated to the FOPS structure

1. With CE marking
2. Without CE marking

Other identification plates can be found:

- » on the diesel engine;
- » on the hydrostatic motors;
- » on the hydrostatic pumps;
- » on the pump drive;
- » on the hydraulic motor/gearbox for rotation.

When inquiring about service or ordering parts, please quote the vehicle serial number, engine serial number and hourmeter reading.

Emission control label

The emission control label is located on the right side of the storage net in the cab.

Patents

This product is manufactured under patent pending. For more information on patents, contact PRINOTH at the address indicated in the present manual.

DIRECTION DESIGNATION

Since the vehicle has a rotating upper structure, designation of left/right, forward/backward is **very** important. When the upper and lower frames are aligned:

- » In a **normal configuration**, the **drive sprockets** are located under the cab and cowling.

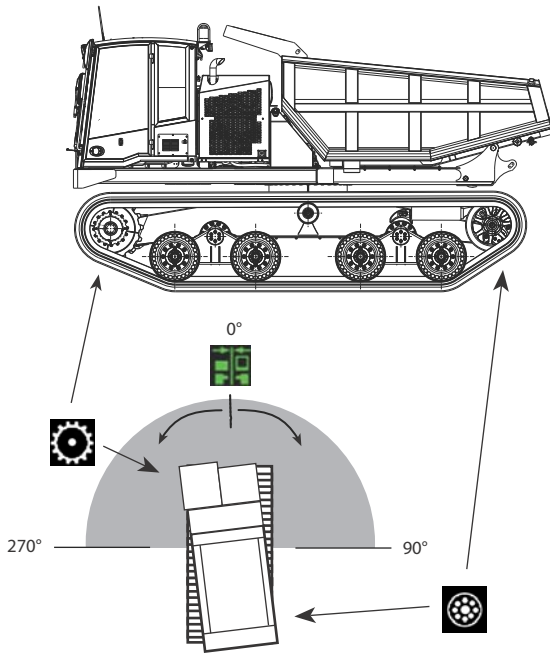

Figure 13
Normal configuration

0275640033

- » In the **inverted configuration** the **idler wheels** are located under the cab and cowling.

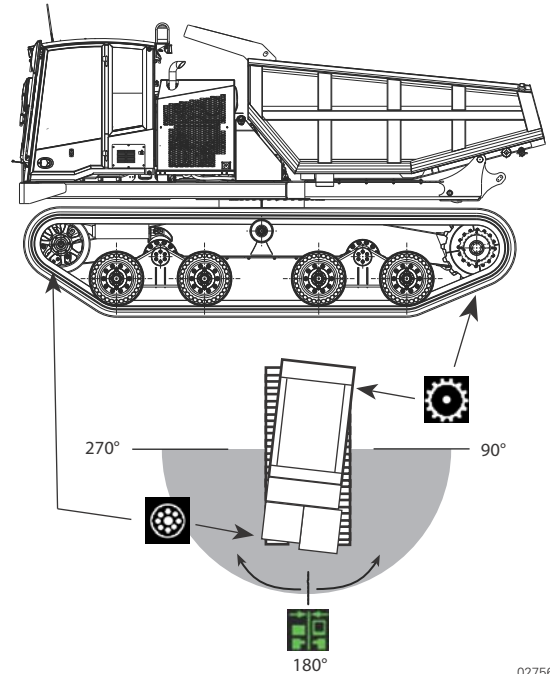

Figure 14
Inverted configuration

0275640034

In this manual, the terms, “left” and “right” refer to the direction as seen from driver’s seat, **looking forward in the normal configuration** (with the drive sprockets located under the cab). For the fault log or other subjects of this manual, the left and right designations will not change, regardless of the position of the upper frame or transmission setting.

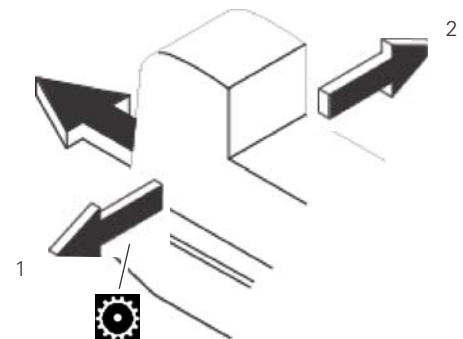

Figure 15
1. Left side
2. Right side

0275640073

RECOMMENDED USE AND PRACTICES

VEHICLE MAIN COMPONENTS

The vehicle incorporates numerous components and systems to perform its functions. Use the following figure to identify the main parts.

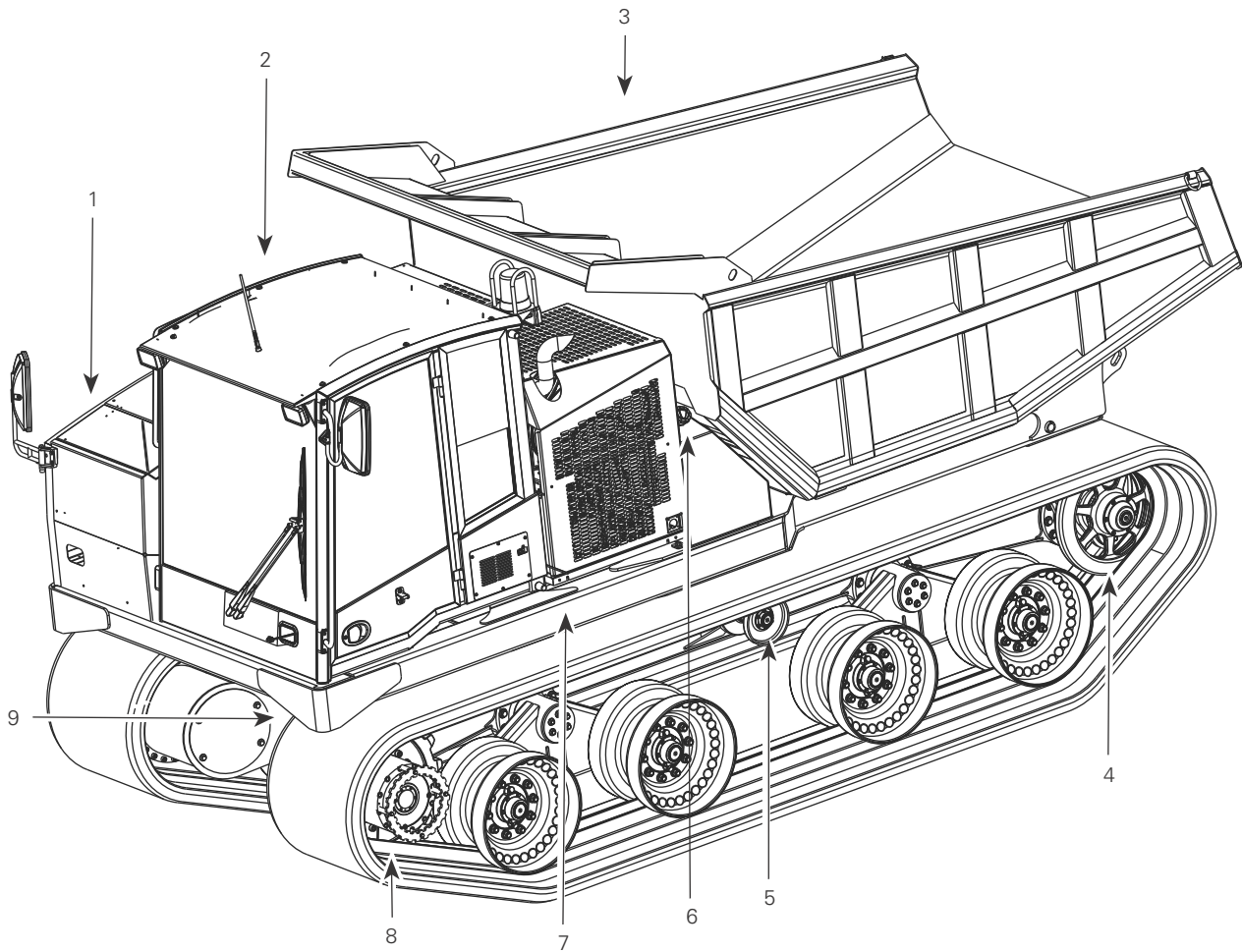

Figure 16

1. Cowling
2. Cab
3. Dump body
4. Idler wheel (and step to access the cab on the right side)
5. Top roller
6. Fuel cap
7. Upper frame
8. Sprocket (and step to access the cab on the left side)
9. Lower frame

0275640041

STEERING COLUMN, PEDAL AND ARM REST CONTROLS

This section describes the controls mounted on the steering column, on cab floor and on the arm rest.

STEERING WHEEL

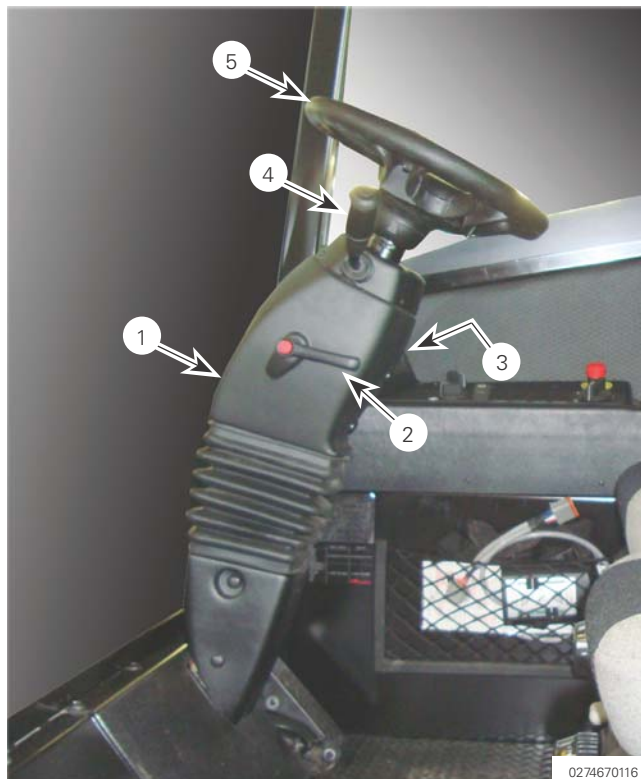

Figure 17

1. Steering column
2. Steering column adjustment lever
3. Ignition switch (not visible on picture)
4. Accessory lever
5. Steering wheel

The steering wheel is connected to a potentiometer which sends a signal to the microcontroller. Using this signal, the microcontroller controls the left and right drive pumps that propel and steer the vehicle.

NOTICE

Do not grab the steering wheel to enter or exit the cab, use the steps on the undercarriage and handles on the door and door frame.

⚠ WARNING

Accident hazard

The operator must be aware of the vehicle configuration and normal/inverted drive setting at all times. In the inverted configuration, the transmission lever and the steering wheel are inverted.

Not taking into account the vehicle configuration may result in severe injury or death.

When the upper frame is rotated to more than 90° and less than 270°, the steering wheel operation is inverted, unless the inversion switch is pressed.

Refer to “Swinging” on page 93 for more details on frame rotation and operation.

STEERING COLUMN, PEDAL AND ARM REST CONTROLS

IGNITION SWITCH AND KEY

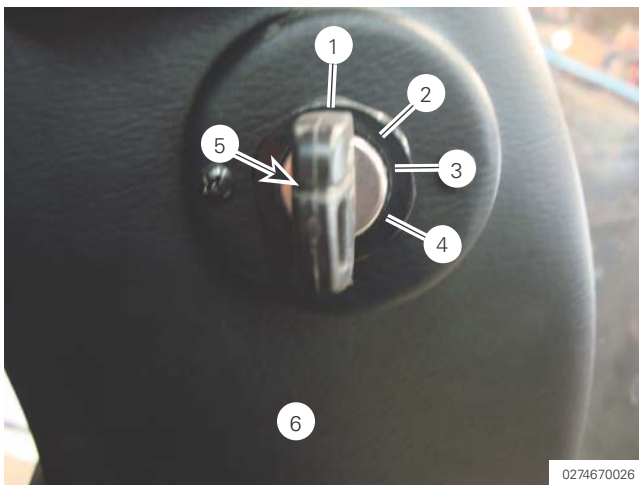

Figure 18

1. "Off" position
2. "Accessories" position
3. "Run" position
4. "Start" position
5. Ignition key
6. Steering column (right side)

Insert the key in the slot of the ignition switch and turn it clockwise to select the appropriate function.

"Off" Position (1)

The "OFF" position stops the engine and turns off some accessories in the cab.

Refer to "Shutting Down the Engine" for more information on stopping the engine.

"Accessories" Position (2)

In the "Accessories" position, power is supplied to most auxiliary systems but the engine does not run with the key in this position.

NOTICE

Leaving the lights, the radio or any other electrical accessory in operation when the diesel engine is not running could drain the batteries. When the engine is not running, turn off all accessories that are not needed.

"Run" Position (3)

The "RUN" position supplies power to the vehicle. If the engine is already running, it keeps running at this position.

"Start" Position (4)

The "START" position is used to start the engine. Check the LCD display for messages before engaging the starter.

STEERING COLUMN ADJUSTMENT LEVER



Figure 19

1. Steering column adjustment lever

⚠ WARNING

Accident hazard

Adjusting the steering column while driving could cause loss of control. Always adjust the steering column when the vehicle is stopped and brakes are applied.

The steering column offers the operator angle as well as length adjustments. Ensure the vehicle is immobilized, release with the lever and adjust to the best possible position, then; return the lever to its original position.

ACCESSORY LEVER



Figure 20

1. Horn button
2. Windshield washer ring button
3. Left flasher function (lever pushed up)
4. Right flasher function (lever pushed down)
5. Front wipers function

The accessory lever is located on the left side of the steering column. It incorporates the following functions:

Horn

Pushing the button at the tip of the lever will activate the horn.

Windshield washer

Pushing the ring at the tip of the lever will activate the windshield washer pump and provide three strokes of the front wipers.

Left flasher

Pushing the lever downward will select the left flasher.

Right flasher

Pulling the lever upward will select the right flasher.

Front wipers

The front wipers are activated by rotating the lever on its axis. The four positions of the lever offer the following functions (in order, clockwise):

- » intermittent (J);
- » Off (O);
- » First speed (I);
- » Second speed (II).

NOTE : The head lamps are controlled from the switches located on the overhead console, not from the accessory lever.

SPEED PEDAL



Figure 21

1. Throttle pedal
2. Pressure applied
3. Pressure released

The throttle pedal controls the engine rotation speed (RPM) and the speed of the vehicle. The vehicle speed increases when pressure is applied to the pedal, the vehicle speed decreases when pressure on the pedal is released.

Release pedal completely prior to engine start and engine shut down.

NOTE : The vehicle will not move until the diesel engine reaches at least 1000 rpm.

STEERING COLUMN, PEDAL AND ARM REST CONTROLS

TRANSMISSION LEVER

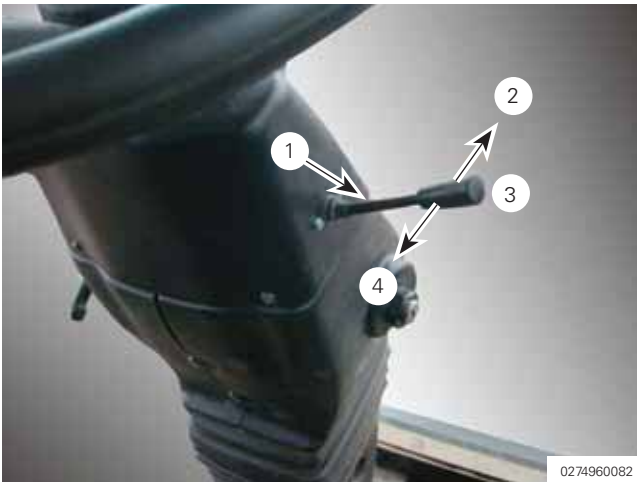

Figure 22

1. Transmission lever
2. Forward (in Normal configuration)
3. Neutral
4. Reverse (in Normal configuration)

The transmission lever, on the right side of the steering column, selects the Neutral or determines the direction of travel, Forward or Reverse.

On the display in the cab, an arrow will indicate the current position of the transmission lever. If there is no arrow, the transmission is in Neutral.



⚠ WARNING

Accident hazard

Rotating the upper frame to near 180° will give the impression that the transmission and the steering wheel commands are inverted. Ensure no one is near the vehicle. Always check to ensure the vehicle moves in the desired direction.

When the upper frame is rotated to nearly 180°, the transmission and steering wheel operation feels like inverted, unless the inversion switch is pressed. Proceed with care.

Refer to “Swinging” on page 93 for more details on frame rotation and operation.

JOYSTICK

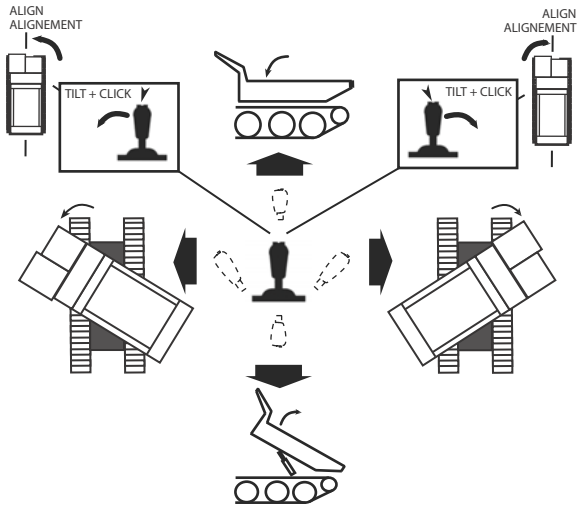

Figure 23

Functions of the joystick

The joystick is used to control the dump body and the angular position of the upper section of the frame.

Swing Control

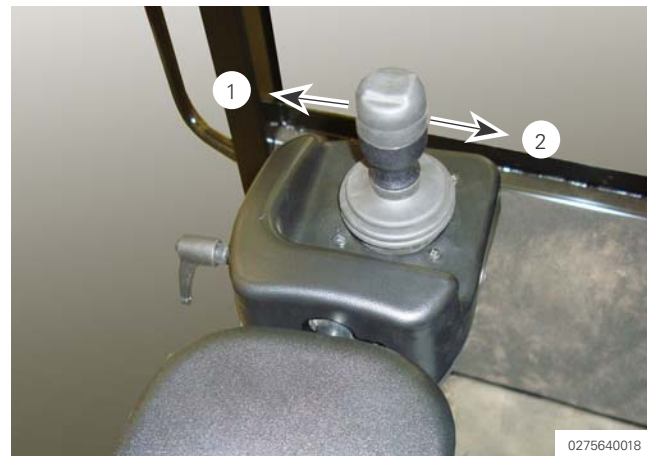

Figure 24

1. Tilt left to swing to the left
2. Tilt right to swing to the right

The joystick enables the operator to rotate the upper structure of the vehicle independently from the lower section of the frame.

Rotation speed is proportional to the angle set on the joystick.

Simultaneous rotation and dumping is allowed.

⚠ WARNING

Accident hazard

Rotating the upper structure while the vehicle is in motion could lead to an accident. Ensure no one is near the swing area. Always check to ensure rotation can be done safely.

To engage the rotation, tilt the joystick in the direction of the desired rotation. Release the joystick when the desired position is reached. The audible alarm (backup alarm) will be heard while the upper frame rotates.

The acceptable oil temperature for swing function operation is above $-20\text{ }^{\circ}\text{C}$ ($-4\text{ }^{\circ}\text{F}$). Maximum rotation speed is 4.5 rpm.

The buzzer in the cab will sound if the joystick is moved laterally while the joystick ON/OFF switch is OFF, the left armrest is raised, the emergency stop switch is engaged or the seat belt is not buckled.

To operate the swing function:

- » The diesel engine must run;
- » The emergency/parking brake must be disengaged;
- » The hydraulic oil temperature must be higher than $-20\text{ }^{\circ}\text{C}$ ($-4\text{ }^{\circ}\text{F}$);
- » The left armrest must be in the lower position;
- » The joystick ON/OFF switch must be ON;
- » The seat belt must be fasten.

It is possible to swing the upper structure while the vehicle is in motion.

If the operator swings the upper frame at more than 90° but less than 270° , the icon for inverted configuration and the red LED will illuminate on the display.



Figure 25
Inverted configuration icon and red LED on display right edge.

For more information on swing control, refer to “Swing-ing” on page 93.

Dump body Control



Figure 26

1. Push forward to lower the dump body
2. Pull backward to raise the dump body

The joystick operates the dump body position cylinders. To raise the dump body, pull the joystick backward. To lower the dump body, push the joystick forward.

NOTE : If installed (CE marking), a position sensor will limit the speed of the vehicle to 10 km/h (6 mph) if the dump body is not completely lowered.

⚠ WARNING

Impact hazard

If the dump body is raised for maintenance, it must be secured with its safety rod to avoid accidental lowering. Refer to “DUMP BODY OPERATION” for safety precautions.

Always install the safety rod before working under the dump body.

To operate the dump body:

- » The diesel engine must run;
- » The emergency/parking brake must be disengaged;
- » The left armrest must be in the lower position;
- » The joystick ON/OFF switch must be ON;
- » The seat belt must be fasten.

It is possible to swing the upper structure as well as driving the vehicle while the dump body is being raised or lowered.

The dump body will operate even if the snowflake icon appears on the display.

For more information on the dump body operation, refer to “DUMP BODY OPERATION” on page 106.

STEERING COLUMN, PEDAL AND ARM REST CONTROLS

Alignment switch

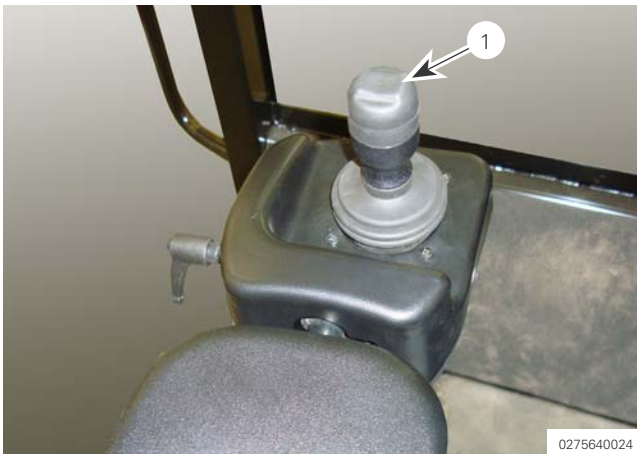

Figure 27

1. Alignment switch

The alignment switch is located on top of the joystick.

⚠ WARNING

Accident hazard

Rotating the upper structure while the vehicle is in motion could lead to an accident. Ensure no one is near the swing area. Always check to ensure rotation can be done safely.

⚠ WARNING

Accident hazard

Personnel could be injured if the upper frame overshoots the correct alignment position and hit something or someone. Always rotate the upper frame manually in critical situations or in tight quarters.

To align the vehicle with the tracks, facing forward (0°) or backward (180°), tilt the joystick in the desired direction and press the alignment switch once (see Figure 29). Hold the joystick until the upper structure stops by itself.

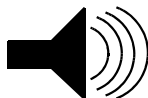

The buzzer inside the cab will sound at the beginning and at the end of the alignment process. The rotation will stop at 0° or 180°.

On the display, an icon will illuminate to indicate that the upper frame is aligned with the tracks.



Figure 28

Icon and LED on the right side of the display

Alignment could be slightly offset to one side or the other by a few degrees (normal situation).

NOTE : As the backlash of the slewing bearing increases with wear, the alignment offset may increase slightly.

It is not recommended to align the vehicle in a slope.

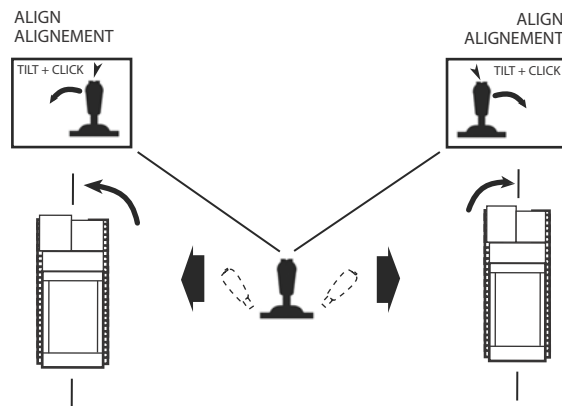

Figure 29

Functions of the joystick with the alignment switch

LATERAL CONSOLE

This section describes the controls mounted on the lateral console. Some items or components shown in this section may be optional or installed only on vehicles intended for specific countries or regions.

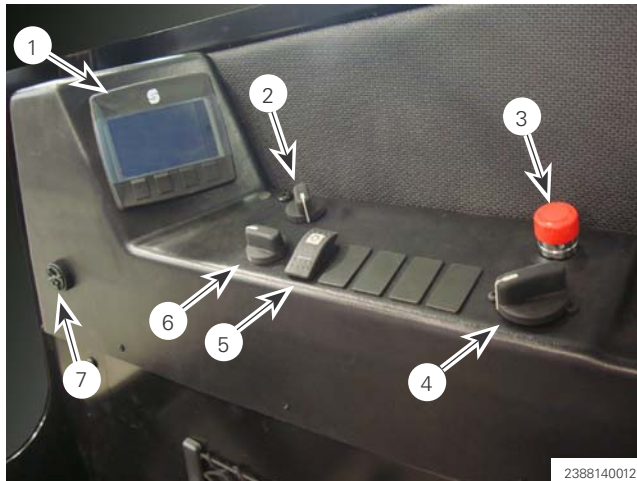

Figure 30

1. LCD Display
2. Heater fan speed control
3. Auxiliary brake switch
4. Engine RPM control knob
5. Air conditioner switch
6. Heater temperature control
7. Audible alarm unit

LCD DISPLAY



Figure 31
LCD display

The display shows information about the vehicle and the engine to help the driver operate the vehicle.

EMERGENCY STOP SWITCH



Figure 32
Emergency stop switch

WARNING

Crush hazard

An operator (and passenger if applicable) without a seat belt fastened could be injured if the brakes are applied while the vehicle moves. Braking distance is extremely short. Always wear the seat belt.

Push down the emergency stop switch (red knob) to cut the signal to the drive pumps and apply the brakes. The vehicle will stop in a very short distance but the engine will keep running.

Rotate the switch clockwise (see arrows) in order to release it and resume vehicle operation.

Once the brakes are disengaged, the transmission lever must be returned to the Neutral position and the speed pedal released before a new command signal (forward or reverse) can be issued to the drive system.

If the button is pressed while the upper frame is in rotation, the brake is applied and the upper frame will stop turning.

NOTICE

Premature wear

Pressing the emergency stop switch while the vehicle is in motion could cause premature wear of the brake components. Apply the emergency brake only in case of emergency or when the vehicle is motionless.

NOTE : The emergency stop switch must be pressed prior to start the engine.

LATERAL CONSOLE

ENGINE SPEED CONTROL KNOB



Figure 33
Engine speed control knob

The engine speed control knob (throttle) sets the rotation speed of the engine (rpm). Turning counterclockwise (towards the turtle) sets a lower engine speed, turning clockwise (towards the rabbit) sets a higher engine speed.

The engine speed control knob can set engine speed from 800 to 1400 rpm. Engine speed higher than 1400 rpm is possible only with the throttle pedal.

Reduce engine speed to the minimum before starting the engine and before stopping it.

NOTE : Leave the setting to the minimum for normal driving. Use a higher setting only for more power when getting the vehicle in motion.

HEATER CONTROL KNOBS

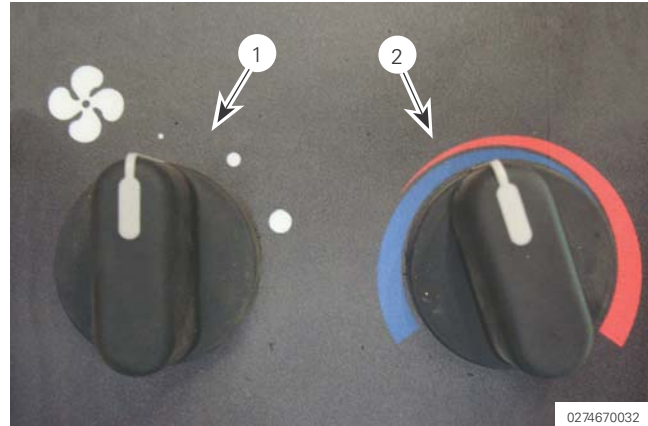

Figure 34
1. Heater fan speed control knob
2. Heater temperature control knob

Fan Speed Control Knob

The knob controls the fan speed which is used for regular heating and defrosting. Turn clockwise to increase the fan speed (toward the larger dots).

Heater Temperature Control Knob

NOTICE

Do not direct hot air from the defrosters directly onto a cold windshield. Localized heat on a cold windshield causes thermal stress which can crack the glass.

Turn this knob to select the appropriate temperature in the cab. The red zone provides warm air, the blue zone provides cool air.

NOTE : For maximum efficiency, ensure the both cab air filters are clean. A clogged filter reduces air circulation. Inspect and clean the filters more frequently in dusty work environment.

NOTE : The air conditioning unit uses the same controls for fan speed and temperature as the standard heater system.

SWITCHES FOR EQUIPMENT AND OPTIONS

According to the options and equipment installed on the vehicle, various switches and controls will be installed on the dashboard, in the cab or even outside the cab. On that particular aspect, every vehicle is unique.

AIR CONDITIONING SWITCH



Figure 35
Air conditioning switch

The air conditioning unit uses the same controls for fan speed and temperature as the standard heater system. Switch the air conditioning system on or off with the switch.

When using the air conditioning unit, close the cab door and lateral windows.

Temperature Control

In colder temperature, set the cab air filter grill (see Figure 99) to “close” The air conditioning will draw fresh air from outside to prevent window fogging and condensation.

In warmer temperature, set the cab air filter grill to “open” so the air is re-circulated which lowers humidity and provides colder air more quickly.

INVERSION SWITCH



Figure 36
Inversion switch

The inversion switch will invert the operation of the transmission lever and steering wheel if the vehicle meets the following conditions:

- » The vehicle is in the inverted configuration: the upper frame has an angle between 90 and 270 degrees with the lower frame.

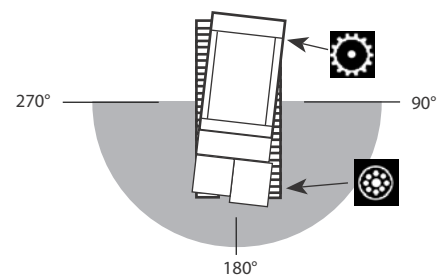

Figure 37
Vehicle in the inverted configuration

- » The vehicle is not moving.
- » Transmission is in Neutral.

If one of the conditions is not met, the inversion will NOT occur and the buzzer will sound when the switch is pressed. The inverted configuration icon will remain lit on the display as well as the red LED on the edge.

When the inversion switch has been activated, the “inverted configuration” icon will **disappear** from the display and the red icon of the display right side edge will turn off. The transmission and steering are then inverted.

When the diesel engine is turned off, the inversion of the transmission and steering is cancelled and the vehicle comes back to the normal configuration.

LATERAL CONSOLE

JOYSTICK ON/OFF SWITCH

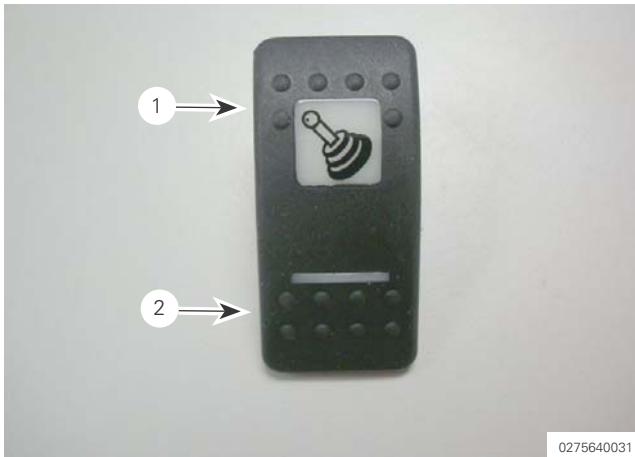

Figure 38

1. Joystick ON
2. Joystick OFF

Press the joystick ON/OFF switch to activate/deactivate the joystick.

When the switch is set to OFF, the joystick is disabled. Rotation, alignment and dump body will not operate. The buzzer in the cab will sound if the joystick is moved. With the switch in this position, the padlock will appear on the display and the yellow LED will illuminate on the right edge of the display.

When the switch is set to ON, the upper frame rotation, alignment and dump body operation are enabled.



Figure 39

Joystick OFF icon and yellow LED on right side edge of the display

CONNECTORS

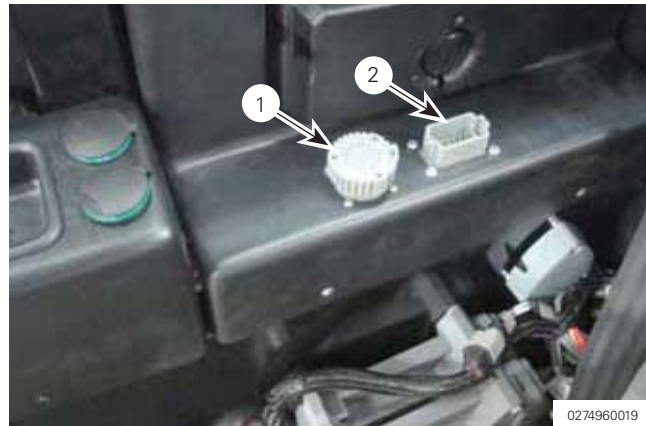

Figure 40

1. Connector for diagnostic and programming of the engine
2. Emergency drive module connector (shown without its cover)

NOTICE

A foreign object or liquid could provoke a connector failure. Always keep the cover on a connector that is not in use.

Emergency Drive Module Connector

A connector is available on the lateral console to connect the emergency drive module. Do not leave the drive module connected when it is not used.

Service Connector

A connector is available on the lateral console to connect a computer to the vehicle. Advanced functions are available only to authorized personnel.

AUDIBLE SIGNAL BUZZER



Figure 41

1. Audible signal buzzer

Most faults, minor or major, will trigger an audible signal to prompt the operator to check the LCD screen. The buzzer is located on the lateral console.

POWER SUPPLY OUTLETS



Figure 42

1. Power supply outlet (12 V)

The lateral console is equipped with two devices providing 12 V power.

The 12 V outlet closest to the cab wall provides continuous power even when the key is not in the ignition switch. The other 12 V outlet provides power only when the key is rotated to the “accessories” or “run” position.

Both outlets will be without power when the battery isolator switch of the vehicle is “OFF”.

STORAGE COMPARTMENT



Figure 43

1. Storage compartment
2. Cup holder

A cup holder and a storage space is provided on the lateral console.

Do not place an opened bottle or an object from which liquid could spill and damage electrical components.

LATERAL CONSOLE

PRE-HEATER CONTROL UNIT



0275580014

Figure 44
Engine pre-heater control unit

This unit controls the engine coolant heater system that may be used to help start the engine in cold weather. The system uses the same fuel and fuel tank as the diesel engine and does not require outside electrical power to operate.

⚠ WARNING

Explosion hazard
Fumes from refuelling could ignite and cause severe injuries or burns.
Always switch off the heater BEFORE refuelling the vehicle.
Do not operate the heater in an area where toxic or explosive materials or fumes may be present.

⚠ WARNING

Asphyxiation hazard
Breathing exhaust gases from the heater could cause severe injuries or even death. Always use the heater when the vehicle is outside or in a well ventilated area.

NOTICE

Damage by freezing
Damage could occur if the heater is operated while the coolant is frozen in the hoses. Ensure the coolant is compatible with the heater specifications.

Use the pre-heater system only when the vehicle is outside (or well ventilated area) and not being refu-

elled. Operation is unrestricted below 1500 m (5000 ft) of altitude. Consult a PRINOTH representative for operation above 1500 m (5000 ft).

It is not recommended to operate the pre-heater when the diesel engine is running.

Refer to the heater supplier literature for safety precautions and other tips on operation/maintenance of the unit.

Preselected starting times

The preselected starting time is the time at which the timer switches the heater on automatically. The Webasto SmarTemp Control fx allows for preset start-up cycles of your Webasto heater up to 7 days in advance with 4 unique programs for each day.

Operating time

The period of time during which the heater is in operation is referred to as operating time. The heater remains in operation for as long as the operating time has been preset. Heater operation can be preselected for any time from as little as 10 minutes to a maximum of 120 minutes (factory preset is 60 minutes).

Remaining Operating Time

The remaining operating time refers to the period of time the heater still continues to remain in operation. This can be changed with duration menu feature.

Setting the SmarTemp Control fx

The Webasto SmarTemp Control fx can be operated using a single rotary dial around the outside of the unit to browse through different menu options. Simply click the selection button () to make your choice. The following sections will define each menu item and its default setting.

Once the power has been connected, the time and date must be set. This can be done by using the rotary knob and the selection button as mentioned above. Within the timer menu, select the day or the specific timer program (T1 - T4) using the rotary knob. Once the day, time, and duration have been entered within the calendar table, press the selection button to set. A checkmark will confirm the program has been saved. Each program can be edited or removed simply by selecting the box again.



0275580015

Figure 45

1. ON/OFF button
2. LCD screen
3. Rotary knob
4. Screw cap
5. Status indicator lights
6. Selection button
7. Micro USB service port

NOTE : The micro USB Service Port is used for the heater diagnostic purposes only. This adaptor cannot be used to charge cell phones or other electronic devices.

Refer to the next table for additional information on the pre-heater operation.

LATERAL CONSOLE

Smartemp Control fx / Operation instructions

	Definition	Default
Time and date	Time & Date allows user to properly set the current date and time. User also has the ability to switch between AM/PM and 24 hour modes.	AM/PM (12 hour)
Mode	Two modes are possible: - Auto mode will allow the heater to turn ON/OFF based on the pre-defined timer programs. Manual ON/OFF operation is still possible while in this mode. - Manual Mode allows the heater to be manually operated via the Webasto button on the Smartemp Control fx. While in Manual Mode, all Auto Mode functionality is disabled (Timers-inactive). Note: While in manual mode the heater will continue to operate based on the pre-defined "Duration" set by the user.	Manual
Duration	Duration allows for the selection of timed heater run-time. Set range is between 10 - 120 minutes selectable by 10 minute increments. While using Manual Mode, the "Duration" setting will be used for the run-time of the heater when the Webasto button is pressed.	60 minutes
Timer	Timer allows the user to set 4 heater start-up cycles per day up to 7 days in advance. Select the day or the specific timer program (T1 - T4) using the rotary knob and the selection button. Once the day, time, and duration have been entered, press the selection button to set. A checkmark will confirm the program has been saved. Each program can be edited or removed simply by selecting the box again. Note: Setting the Duration run-time before setting a timer program will default all new programs to the user defined duration time.	No presets
Skip	The Skip feature looks similar to timer programming; however when a specific timer program is selected, it will update the checkmark to an "s" for skipped. When a program has been skipped, it will disable that specific timer program for one cycle (7 day period). Preset timer programming will reactivate after this one-time skip cycle.	N/A
LVD	LVD "Low Voltage Disconnect" allows the user to adjust the battery voltage level at which the Webasto Smartemp Control fx will shut down heater functionality. If battery voltage is equal to or less than the threshold selected +0.1v, the heater will not start. i.e. if an 11.5v threshold is selected the heater cannot be started until B+ has reached 11.7v. 12 volt - Range between 11v - 12.5v 24 volt - Range between 21v - 25.5v	12.1 v 24.2 v
Error codes	This section will log the last 5 error codes and the date that it was set. Highlight and select an error code for a full description. If the heater produces an error code, the status indicator lights will flash red and the error will display on the main screen. Error codes cannot be reset through the Webasto Smartemp Control fx. Refer to the heater service manual for resetting an error code. Note: Error code functionality does not apply to Thermo Top C heaters. Errors codes for this product can still be obtained using PC Diagnostics. Refer to the applicable service manual by visiting www.techwebasto.com for detailed PC diagnostics information	No errors
Hour meter	The hour meter logs the operating hours that the heater is commanded "ON" from the Smartemp Control fx. Note: For warranty purposes a diagnostic printout is still required where applicable. This hour meter is for reference only	N/A
Default	Default allows the user to perform a factory reset of the control settings and saved timer program data.	N/A
SW version	This displays the firmware version of the Webasto Smartemp Control fx.	Installed version
Back	Select this to return to the previous screen.	N/A

LCD DISPLAY

The LCD display provides information to the operator about the vehicle operation and diesel engine operation.

When the key is inserted in the ignition switch and turned to the “run” position, the introduction screen appears for a few seconds. Then, the main screen comes into view. Use the push buttons underneath the screen to navigate in the numerous screens available on the display. Access to some of the menus and screens is restricted to authorized personnel.

MAIN SCREEN

Information is available on the *Main* screen of the display. Refer to the following for details.



Figure 46
Main screen with icons that may appear (not all are shown)

Audible Alarm

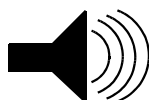

Minor and major faults will trigger an audible alarm to alert the operator of an abnormal situation. Some function relating to the frame rotation or dump body also sound the audible alarm.

LED INDICATORS

Fault indication

Yellow or red LEDs on each side of the screen will flash to notify the operator about a problem on the vehicle.

When the yellow LEDs flash, a minor fault has occurred. The vehicle can still operate but requires immediate attention. Icons on the screen will provide guidance to pinpoint the problem.

When the red LEDs flash, a major fault has occurred. A major fault will immobilize the vehicle. Icons on the screen will provide guidance to pinpoint the problem.

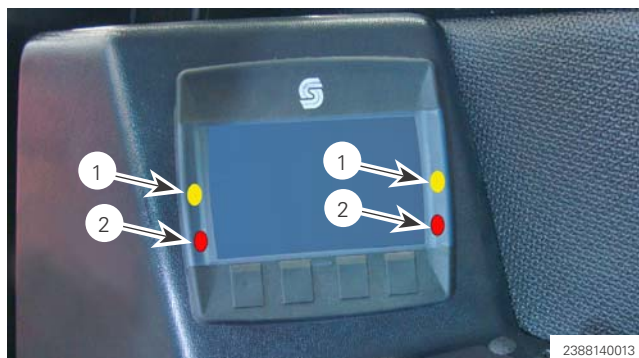

Figure 47
1. Minor fault LEDs (yellow)
2. Major fault LEDs (red)

Rotation indication

The LEDs on the **right side** of the display provide a rapid indication of the status of the rotation system.



Figure 48
1. Upper frame is centered (green LED)
2. Joystick OFF (rotation and dumping are disabled - yellow LED)
3. Upper frame is inverted (transmission and steering are NOT inverted - red LED)

LCD DISPLAY

MAIN SCREEN INDICATIONS

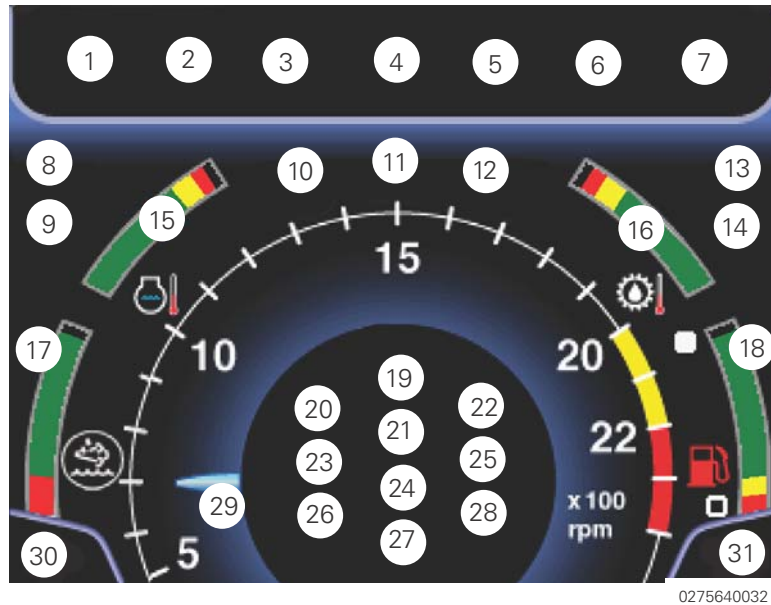



























Figure 49

POS.	ICON	INDICATION	SECTION WITH DETAILED INFORMATION
1		Engine oil pressure too low	See "Vehicle Data" on page 47
2		Engine coolant temperature too high	See "Vehicle Data" on page 47
3		Weak battery indication	See "Vehicle Data" on page 47
4		Clogged air filter indication	See "Vehicle Data" on page 47
5		Hot hydraulic oil (tank). Slow down to allow oil to cool. Investigate. Check if oil cooler is dirty.	See "Vehicle Data" on page 47 See "High oil temperature" on page 94
		Hot hydraulic oil (planetary) - first level. Slow down to allow oil to cool.	See "Oil in the planetary gearboxes" on page 95
		Hot hydraulic oil (planetary) - second level. Slow down to allow oil to cool.	See "Oil in the planetary gearboxes" on page 95
6		Hydraulic oil level	See "Vehicle Data" on page 47

POS.	ICON	INDICATION	SECTION WITH DETAILED INFORMATION
7		Hydraulic oil pressure too low	See "Vehicle Data" on page 47
8		DEF/AdBlue low level.	See "DEF/AdBlue® Level" on page 85
9		CAN fault : main microcontroller	Investigate electrical circuit : cables, major components and sensors.
		CAN fault : diesel engine ECM	Investigate electrical circuit : cables, major components and sensors.
		CAN fault : second microcontroller (joystick functions)	Investigate electrical circuit : cables, major components and sensors.
10		ECM major fault.	See "DM1 log (active faults)" on page 50
11		Glow plug activated. Wait until the icon disappear before cranking the starter.	See "Starting the Engine" on page 87
12		ECM minor fault.	See "DM1 log (active faults)" on page 50
13		Aftertreatment system fault.	See "DM1 log (active faults)" on page 50
14		Minor fault. The vehicle is still functional but requires attention, otherwise permanent damage could occur.	See "Microcontroller fault log" on page 49
		Major fault. The vehicle is no longer operational, one or more critical component has failed.	See "Microcontroller fault log" on page 49
15		Engine coolant temperature	See "Vehicle Data" on page 47
16		Hydrostatic oil temperature	See "Vehicle Data" on page 47
17		Flashing DEF icon activates when DEF level is low.	See "DEF/AdBlue® Level" on page 85
18		Flashing fuel pump icon activates when fuel level is very low.	See "Fuel Level" on page 85

LCD DISPLAY

POS.	ICON	INDICATION	SECTION WITH DETAILED INFORMATION
19		Transmission current setting (up=forward*) * : in normal configuration	See "Transmission Lever" on page 30
		Transmission current setting (down=backward*) * : in normal configuration	See "Transmission Lever" on page 30
20		Engine operating hours (hourmeter)	See "Engine Operating Hours" on page 170
21		Hydraulic oil temp (-20 °C / -4 °F) is below allowed range for upper frame rotation. Hydraulic oil temp (-5 °C / 23 °F) is below, allowed range for maximum vehicle speed.	See "Oil temperature and swing system" on page 96. See "Oil temperature and drive system" on page 94
22		Time of day	See "Set Up" on page 51
23		Release pedal or release brakes or buckle safety belt	See "Setting the Vehicle in Motion" on page 90
		Release pedal	See "Setting the Vehicle in Motion" on page 90
		Set transmission to neutral	See "Setting the Vehicle in Motion" on page 90
24		Limp home mode.	See "Driving a Partially Disabled Vehicle" on page 98, See "Dump body position sensor" on page 107
25		Parking brake icon: brake applied by the operator.	See "Parking Brake" on page 97
		Auto-brake icon: brake applied by the microcontroller.	See "Auto-brake" on page 94
26		Upper frame is centered	See "Alignment switch" on page 32
27		Joystick is OFF (all joystick functions)	See "Joystick on/off Switch" on page 36
		Swing function is disabled, oil temp is below -20 °C (-4 °F)	See "Joystick" on page 30
28		Upper frame is inverted	See "Swinging" on page 93

POS.	ICON	INDICATION	SECTION WITH DETAILED INFORMATION
29		Engine RPM	See "Vehicle Data" on page 47
30		Left flasher	See "Accessory Lever" on page 29
31		Right flasher	See "Accessory Lever" on page 29

LCD DISPLAY

NAVIGATING

The function of each button changes according to the screen presented. The function is shown on the bottom of the screen above each button (see Figure 76).

Press the last button to the right once. A black narrow band will appear at the bottom of the screen. The down arrow permits confirm and leave the main screen. The "X" cancels the command.



Figure 50

1. Last button on the right to access menus

Press the same button again to exit the main screen and navigate.



Figure 51

1. Arrow pointing button to exit the main screen and access the menu icons

Leaving the main screen gives access to the menu icons.

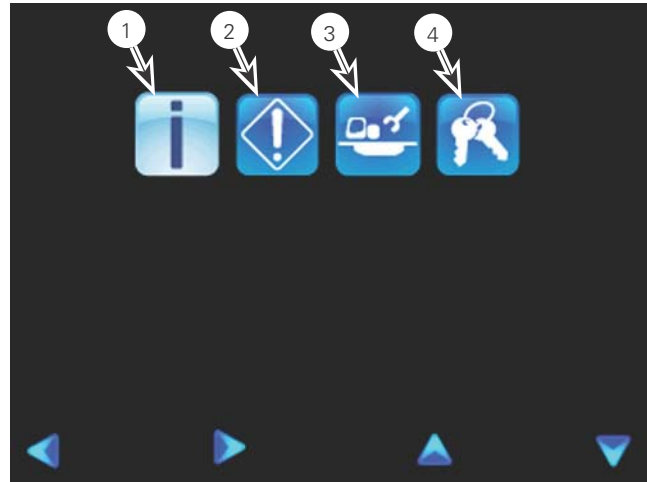

0274670189

Figure 52

1. Vehicle data
2. Fault log
3. Set up
4. Menus with restricted access (password required)

Use the arrows to select an icon. The icon selected will take a lighter colour. Then press the down arrow to enter the corresponding screen or to access the sub-menu.

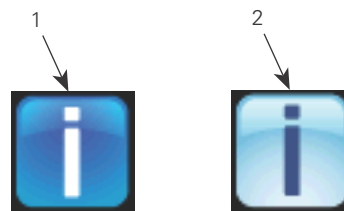

0274670272

Figure 53

1. Icon not selected (example)
2. Icon selected (example)

Vehicle Data

The Vehicle Data menu provides information with more details than the Main Screen.

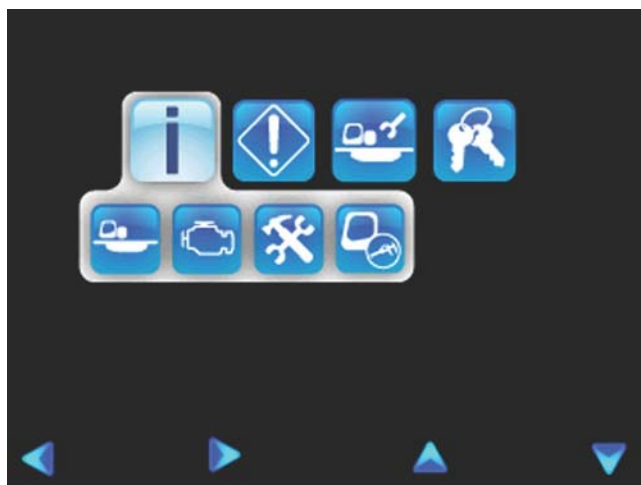

Figure 54
Vehicle data selected

0274670207

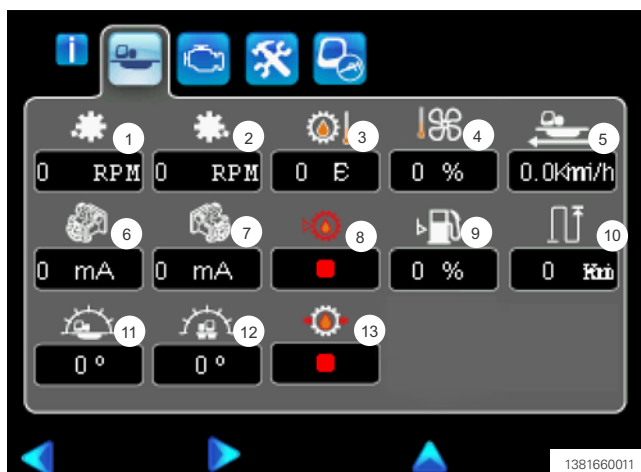

Figure 55
Vehicle data

1. Left hydrostatic motor rpm
2. Right hydrostatic motor rpm
3. Hyd oil temperature
4. Cooling fan speed in percentage
5. Vehicle forward speed
6. Left hyd. pump current
7. Right hyd. pump current
8. Hyd. oil level (red dot: too low, white dot: OK)
9. Fuel level remaining in percentage
10. Distance covered by vehicle
11. Slope indicator - up/down
12. Slope indicator - lateral
13. Hyd. oil pressure (red dot: too low, white dot: OK)

1381660011

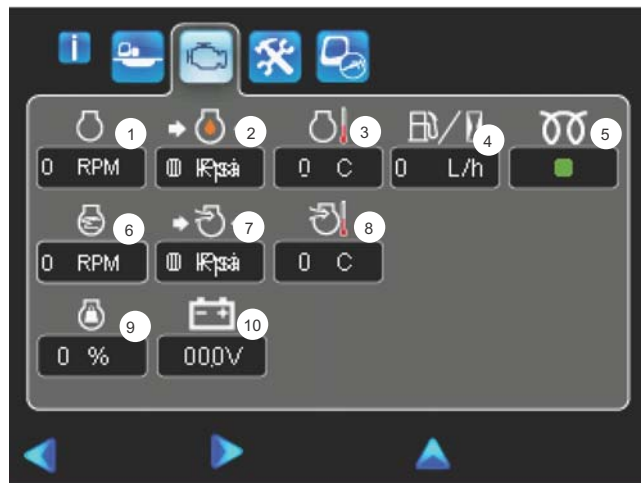

Figure 56
Engine and battery data

1. Diesel engine current rpm
2. Diesel engine oil pressure
3. Diesel engine coolant temperature
4. Diesel engine fuel consumption
5. Icon not used on the Panther T22
6. Diesel engine rpm setting
7. Diesel engine air intake pressure
8. Diesel engine inlet air temperature
9. Diesel engine load (in percent)
10. Battery voltage

0275230091



Figure 57
Microcontroller and display software part numbers

1. MP1, no of the main microcontroller software
2. MP2, no of the second microcontroller software
3. Display, no of the software
4. P1D, no of the software parameter

0275250089

NOTE : All numbers shown on the screen above are for example only. Do not use them.

LCD DISPLAY



0274960090

Figure 58

Current value of potentiometers and transmission selector:

1. Throttle pedal potentiometer current value
2. Steering wheel potentiometer current value
3. Transmission lever current selection
4. Engine speed potentiometer current value

LCD DISPLAY

DM1 log (active faults)

Once in the fault log, selecting the Electronic Control Module (ECM) faults will give access to information on the active engine faults.

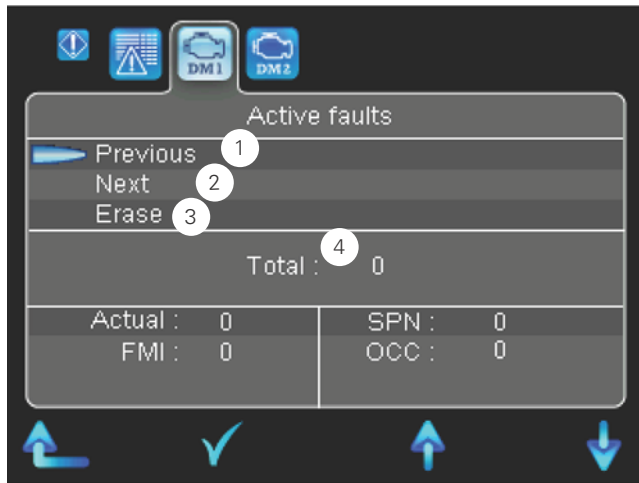

0274670209

Figure 61

1. Previous active fault
 2. Next active fault
 3. Erase the fault
 4. Number of active faults that are currently detected
- NOTE : The blue arrow indicates the selection (here : Previous)

Procedure

- » Enter the DM1 log screen;
- » Select the desired fault (previous, next) or erase;
- » Read the result on the lower part of the screen.



0275560033

Figure 62

The screen provides information:

Current : Current fault selection
 FMI : Failure Mode Identifier
 SPN : Suspect Parameter Number
 OCC : Occurrence (how often the fault occurred)

Write down the code and contact your Caterpillar authorized representative to solve the problem.

DM2 log (previous faults)

Once in the fault log, selecting the Electronic Control Module (ECM) faults will give access to information on the previous engine faults

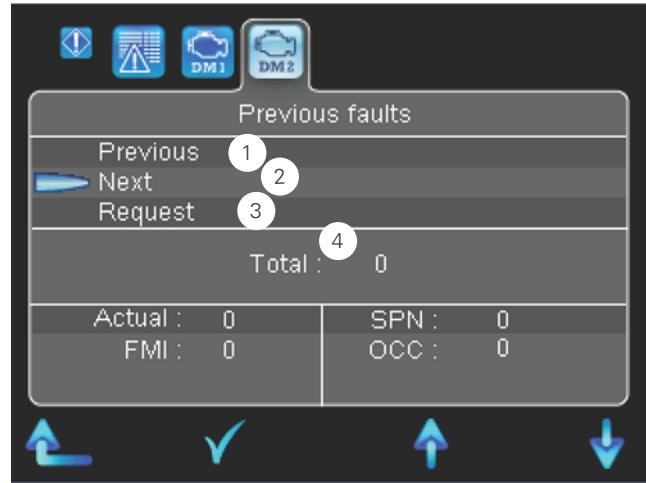

0274670210

Figure 63

1. Previous inactive fault in the log
 2. Next inactive fault in the log
 3. Request function
 4. Number of inactive faults (that are no longer detected)
- NOTE : The blue arrow indicates the selection (here : Next)

Procedure

- » Enter the DM2 log screen;
- » Select Request;
- » Select the desired fault (previous or next);
- » Read the result on the lower part of the screen.



0275560033

Figure 64

Current : Current fault selection
 FMI : Failure Mode Identifier
 SPN : Suspect Parameter Number
 OCC : Occurrence

Write down the code and contact your Caterpillar authorized representative to solve the problem if required.

Set Up

The Set Up menu provides information on input and output signals of certain systems/components and also menus to select measuring units, language and time of day.

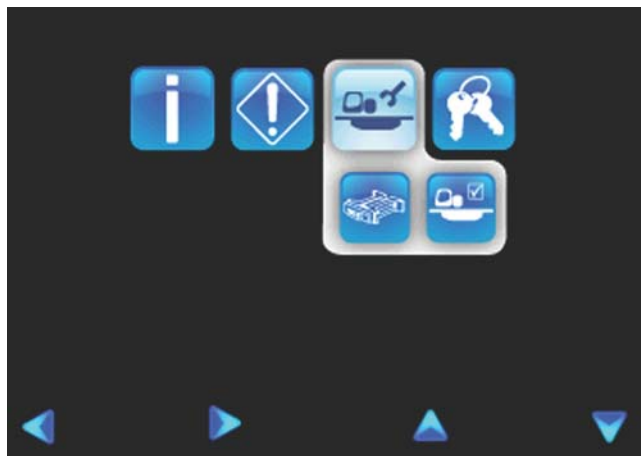

Figure 65
Input/output data

0274670197

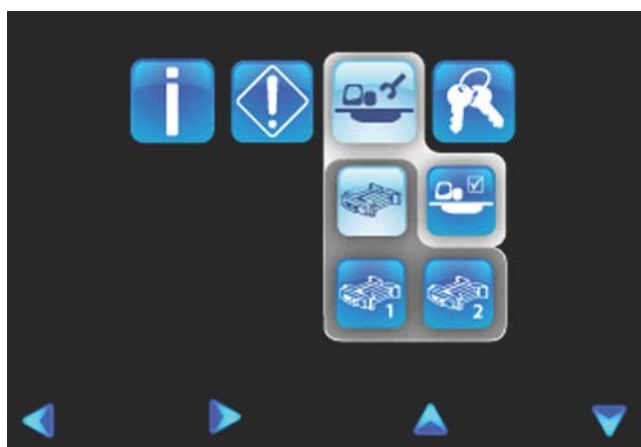
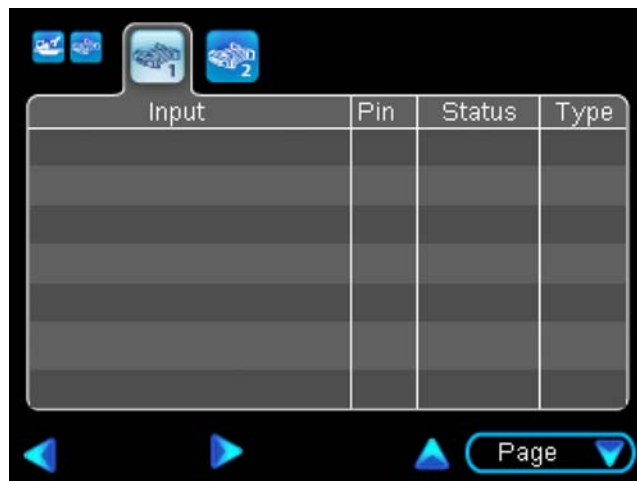

Figure 66
Input/output data - microcontroller no 1

0274670198

The Set Up menu provides information on input and output signals of certain systems/components and also menus to select measuring units, language and time of day.

NOTE : A basic vehicle is equipped with one microcontroller. When the vehicle is equipped with the Premium Package, there are two microcontrollers on board. The second microcontroller is dedicated to handling the additional input and output signals that come with the Premium Package.



1939680014

Figure 67
Input/output signals - microcontroller no 1

Abbreviations used in the Set Up menu

Column title	Description
AIN	Analog input
DIN	Digital input
DOUT	Digital output
FreqIN	Frequency input
mV	millivolt
PWM	Pulse width modulation
RheoIN	Rheostat input (resistance)

LCD DISPLAY

MP2 Microcontroller

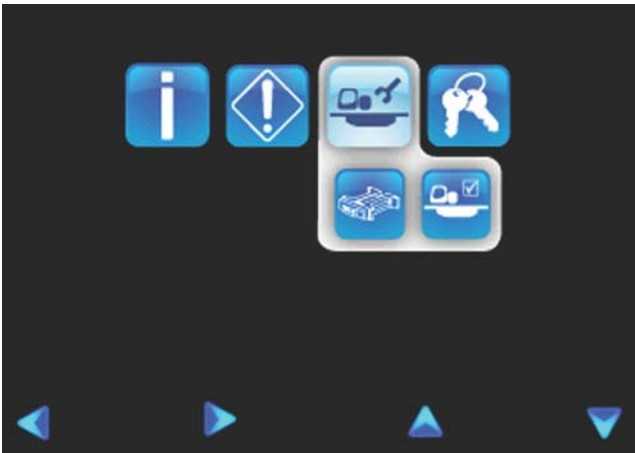

Figure 68
Input/output data

0274670197

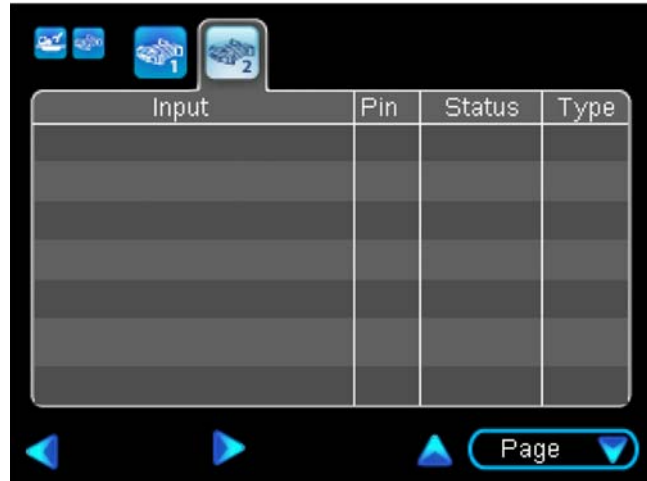

Figure 70
Input data - microcontroller no 2 - Premium option installed

1939680015

See the table on the previous page for the description of the abbreviations that appear in the Set Up menu.

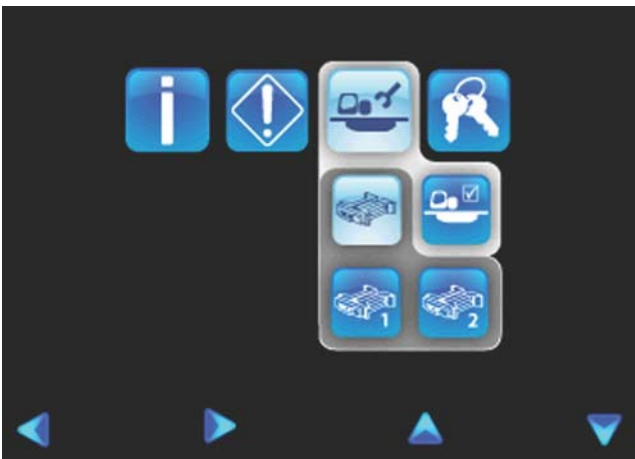

Figure 69
Input data - microcontroller no 2 - Premium option installed

0274670198

NOTE : The No 2 microcontroller comes with the Premium option only.

Measuring units, time and language

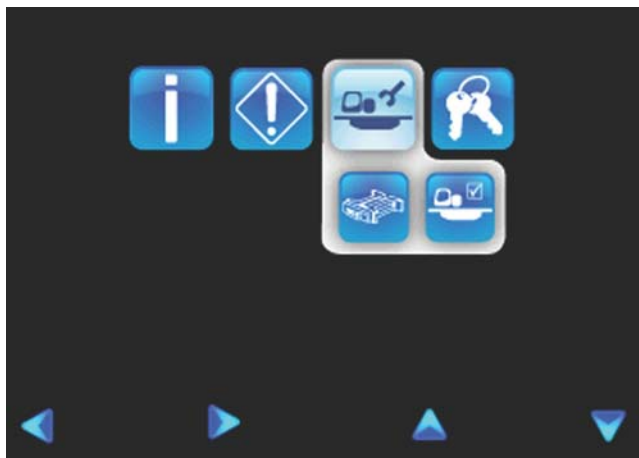

Figure 71
Input/output data

0274670197

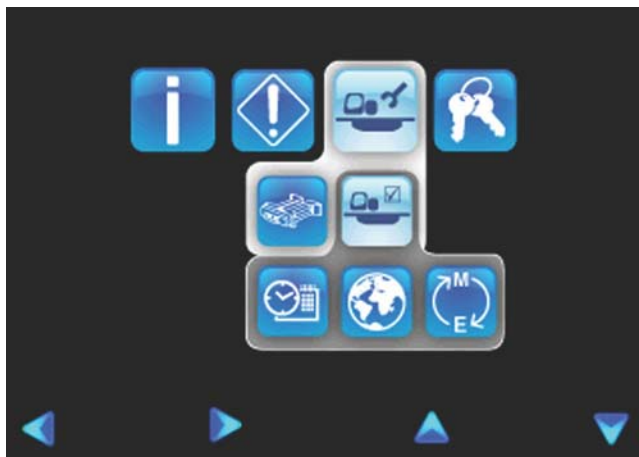
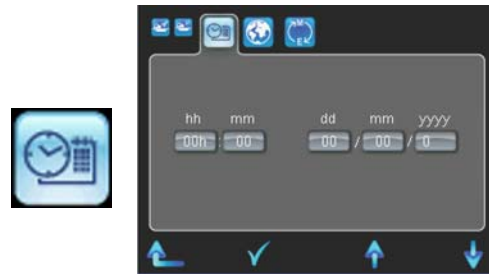
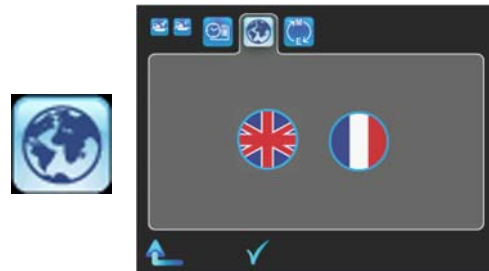

Figure 72
Time, language and measuring units

0274670199



0274670200



0274670201

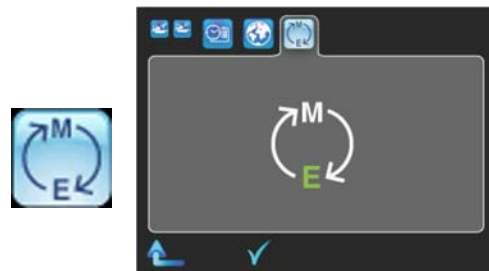

0274670202

Figure 73
Time of day (top), language (middle) and measuring units (bottom) adjustment/selection according to the icon selected

LCD DISPLAY

Menus with restricted access

There is a set of menus with restricted access. These menus cover calibration, engine presets, inclinometer settings. An other level of restricted menu provides access to advanced parameters only to be used by service technicians.

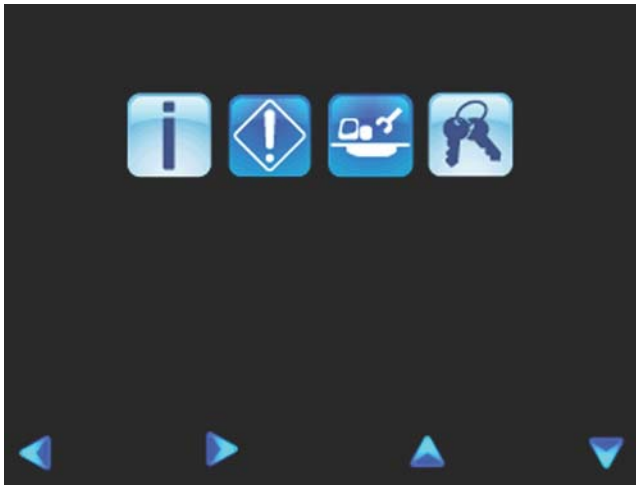

Figure 74
Access code (key icon)



Figure 75
Enter the password access to restricted menus

Refer the appropriate manual for more information on menus with restricted access.

Navigation icons at bottom of LCD screens

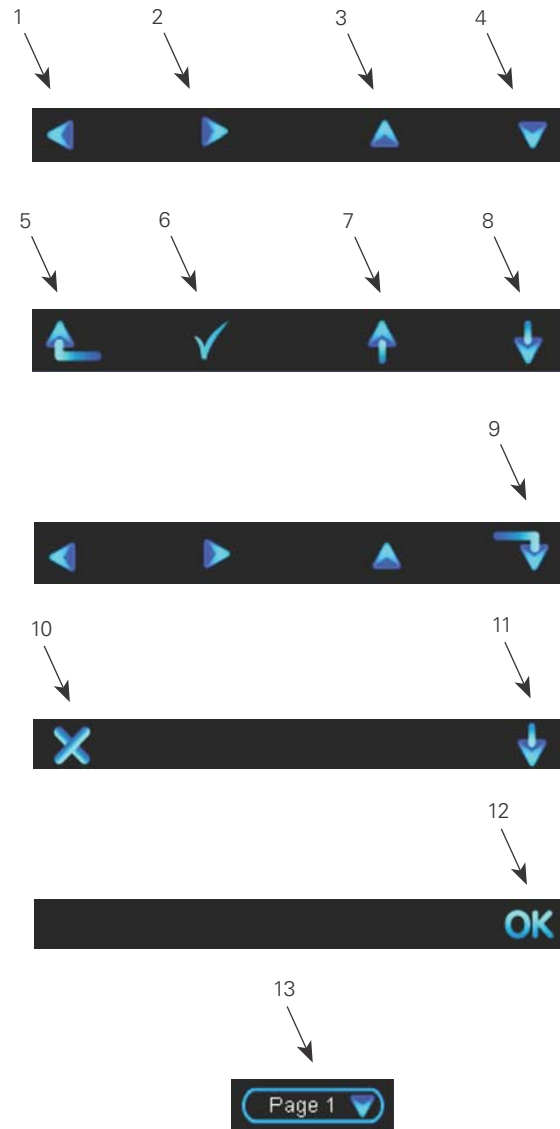

Figure 76

1. Move left
2. Move right
3. Move up
4. Move down
5. Exit a screen where an entry was made
6. Confirm or select an entry
7. Move up
8. Move down
9. Enter a field to make an entry
10. Cancel a command (or entry) or erase a fault on screen
11. Move down to the next sub-menu
12. Confirm a command
13. Move to the next screen when multiple screens (or pages) are available

Information messages

To alert the driver, messages (popup) may appear on the display if a situation or problem occurs.

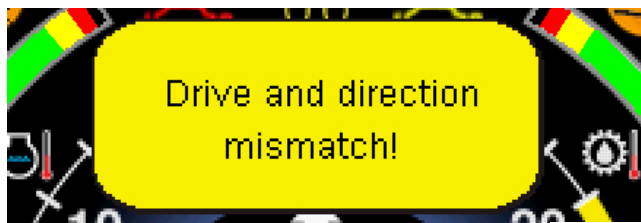

Figure 77
Drive and direction mismatch message on the display

The message shown in the previous figure may occur when the rotation sensor fails or if its signal is no longer received by the microcontroller.

In this situation the upper frame can still rotate but :

- » the alignment function is cancelled;
- » the minor fault icon will appear on the display;
- » the buzzer will sound;
- » the default value is used by the microcontroller (the default value is the “normal configuration” regardless of the real configuration);
- » the red inverted configuration icon will flash on the display;
- » the green alignment icon will not appear;
- » an entry will be logged in the fault log.

If this message appears, consult a mechanic at once for a service procedure. If the sensor is replaced, it will require a calibration.

Clearing faults

A fault is an anomaly indicated by an icon, a high hydraulic oil temperature for example. Some anomalies also trigger flashing LEDs on each side of the display. Yellow LEDs are for minor faults while red LEDs are for major faults.

NOTE : All faults are not treated the same way by the microcontroller. Some have little impact (like fuel low level), some will generate a 50% cut in the drive signal to the drive pumps while some will prevent the vehicle from being set in motion.

The operator may dismiss the problem and continue to operate the vehicle. In that case, the warning indications on the screen will re-appear periodically.

The operator may solve the problem on site or a mechanic make the repair in a shop. If this is the case, proceed as follows to clear the fault indication on the display:

- » Turn off the engine and re-start it, or:
- » Complete the erasing sequence as follows:
 - » Execute a complete brake application cycle (safety belt of the seat must be buckled).
 - » Press the last button to the right (under the down arrow icon) to access the icons shown on the following figure, then press the last button to the left (under the “X” icon).



Figure 78

NOTE : The icons will disappear after a few seconds.

One of the above procedures is required to modify the fault status from active to passive. On the *Fault log* page of the display, the Qty of that fault will be increased by one.

Remember that clearing a fault does not eliminate a problem. A problem must be solved by the operator or an authorized technician and then the fault has to be “cleared” as described previously. Once cleared, the fault goes from *active* to *passive* and will be recorded in the microcontroller fault log.

OVERHEAD CONSOLE

OVERHEAD CONSOLE

This section describes the controls mounted on the overhead console. Some items or components shown in this section may be optional or installed only on vehicles intended for specific countries or regions.



Figure 79

1. Radio unit
2. Light switches
3. Directional light controls

RADIO UNIT



Figure 80

Radio (may differ from picture)

The radio is equipped with two loudspeakers and an antenna. Refer to the supplier literature for detailed operating instructions.

It is recommended to keep the volume adjusted so the operator is able to hear horn, alarm and other sounds which could help avoid an incident/accident.

Switch off the radio when not in use.

MONITOR FOR THE REAR VIEW CAMERAS



Figure 81

1. On/Off button
2. Menu/selection button
3. Camera selection
4. Down arrow
5. Up arrow
6. Rotate image (Back/Exit when in Menu Mode)

The monitor for the rear view cameras is located on the lateral console inside the cab.

Use the rear view system to enhance dumping precision and as an additional viewing angles to detect potential obstacles.

WARNING

Crush hazard

Do not use the rear view camera as a safety feature. Bad lighting conditions or dirt on the lens could impair rear vision. Look directly at the rear or use a spotter to backup the vehicle or to safely dump a load.

Use of this system is not a substitute for safe, proper or legal driving. Never backup while looking at the monitor alone.

The monitor can be configured to show the image either camera or, using the split screen function, show the images of both camera.

Use the menu on the screen to adjust and configure the unit.

LIGHT SWITCHES



Figure 82
Light switches on the overhead console

NOTICE

Leaving the lights “on” when the diesel engine is not running could drain the batteries. Turn off the lights when not needed.

Headlamp Switch



Figure 83
Press the switch to turn on the main headlights.

0274670075

Second headlamp Switch



Figure 84
Press the switch to turn on the second set of headlights.

0274670075

Rear Working Light Switch



Figure 85
Press the switch to turn on the rear working lights.

0274670077

Beacon Light Switch



Figure 86
Press the switch to turn on the amber beacon light.

0274670079

REAR WIPER SWITCH



Figure 87
This switch controls the operation of the rear window wiper and washer fluid.
Press the switch to the first stop to activate the wiper. Press the switch to the second stop (spring-load position) to activate the washer fluid pump.

0274670081

COMPONENTS INSIDE THE CAB

COMPONENTS INSIDE THE CAB

Some items or components shown in this section may be optional or installed only on vehicles intended for specific countries or regions.

KEY



Figure 88
Vehicle key

One key is required to operate the vehicle. It permits access/operate the following components:

- » Ignition switch;
- » Cab door lock;
- » Engine compartment access panels;
- » Fuel tank filler cap.

Copies of the key are available from the PRINOTH parts department.

DOOR



Figure 89

1. Cab door
2. Exterior door latch

⚠ CAUTION

Crush and impact hazard

An unsecured (unlatched) door could swing open or close and hurt someone in the process. Always secure the door fully opened or closed (with respective latches) before operating the vehicle. Bring the vehicle to a complete stop before opening or closing the door.

⚠ CAUTION

Accident hazard

Driving the vehicle with the door opened could allow foreign objects to enter the cab and hit or distract the driver (or passenger) which could cause an accident. Always drive with the door fully closed unless work conditions requires an open door.

The door is equipped with two latches so it can be secured in the fully opened or fully closed position.

Unless required by the type of work, it is recommended to drive the vehicle with the door closed.

Always stop the vehicle completely on level ground before opening or closing the door.

Exterior door handle



Figure 90

Exterior door handle with key hole

Pull out the door handle to open the door. To lock or unlock the door, insert the key and turn 90°. The door lock uses the same key as the ignition switch.

Exterior door latch

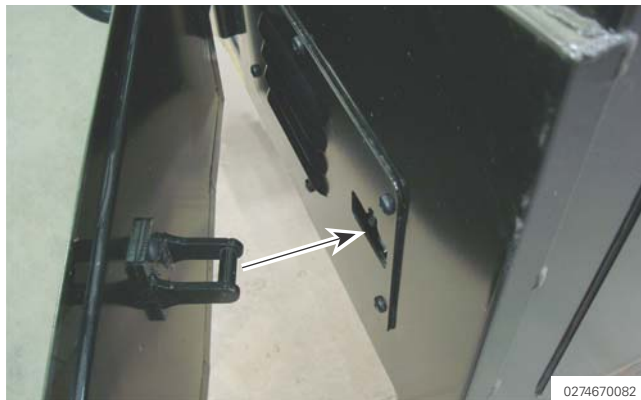

Figure 91

Exterior door latch (to secure door in a "latched-open" position)

The exterior door latch is used to secure the door completely opened. Push the door firmly on the cab side wall to engage the latch.

Interior door handles



Figure 92

Interior door knob

To open a fully closed door from the interior of the cab, push down the interior door knob and push out the door.



Figure 93

1. *Interior door T-handle (to release a "latched-open" door)*

To close a "latched-open" door, pull forward the T-handle at the bottom of the left cab wall and swing the door to close it.

COMPONENTS INSIDE THE CAB

LEFT LATERAL WINDOW

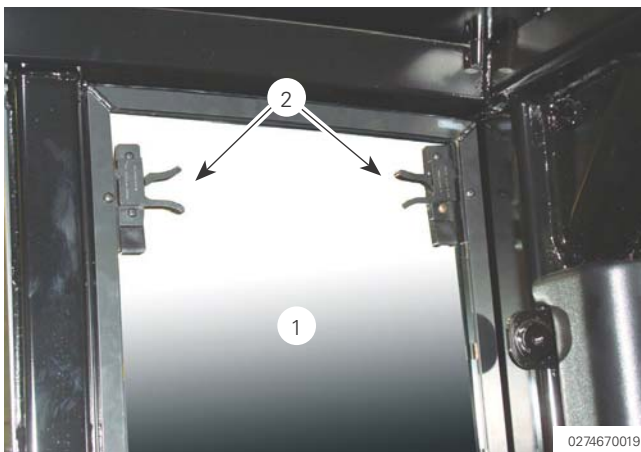

Figure 94

1. Lateral window
2. Tabs

Use the tabs to open, close or lock in position the left lateral window.

To slide the window up or down, squeeze together the top and bottom tabs on each side of the window, then move the window up or down as desired. Release the tabs to lock in position on the nearest notch.

RIGHT SIDE FRONT WINDOW



Figure 95

1. Window latch
2. Right side front window

The right side front window can be opened partially to allow fresh air in the cab. Use the latch to lock the window opened or closed.

The latch may be disconnected by pulling out the locking pin.

NOTICE

Damage may occur if the opening of the right lateral window and the upper access panel of the engine compartment is not coordinated.

CAB STORAGE NET

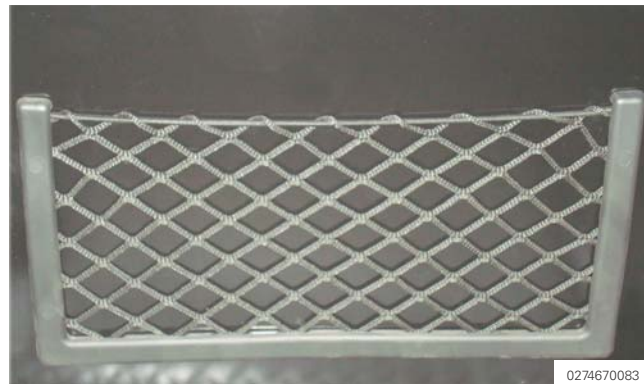

Figure 96

Storage net

There is a storage net on the right side of the cab, under the window.

DOMELIGHT

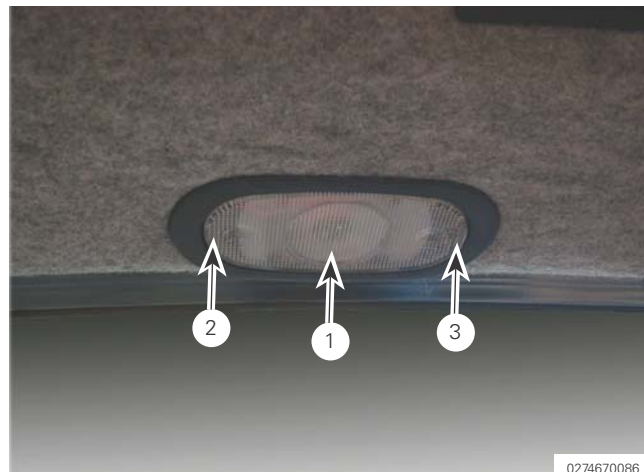

Figure 97

1. Center position
2. Always ON position
3. Always OFF position

Push on the front or rear edges of the lens to turn on or off the dome lamp.

CAB AIR VENTS AND GRILL

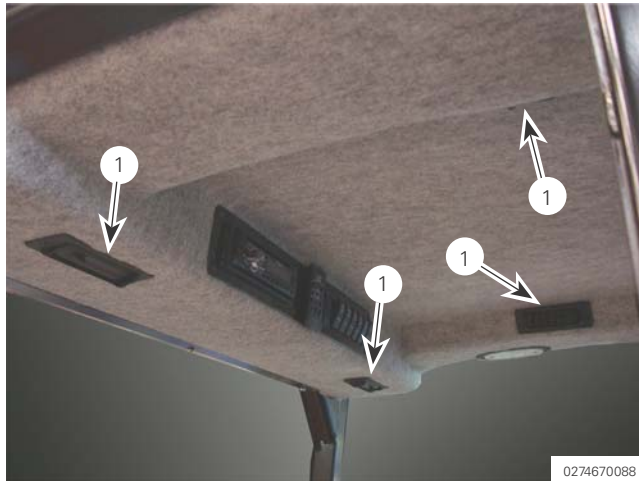

Figure 98

1. Ceiling air vents (floor vents not shown)

Cab Ventilation

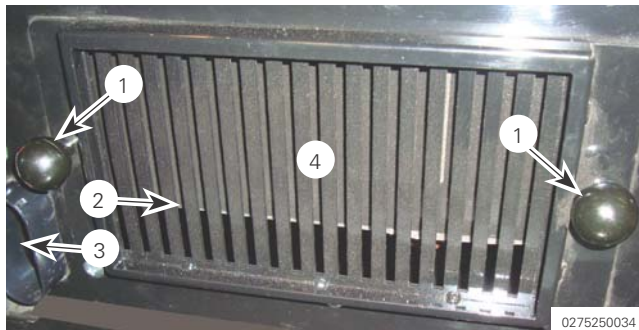

Figure 99

1. Grill locking nuts
2. Control tab pushed to open the grill
3. Control tab pulled to close the grill
4. Air filter foam removed to show details

The space behind the seat contains a housing with some of the heating/air conditioning components. On the front of this housing, there is a sliding grill. To open or close the grill, loosen the two round knobs, move the grill as desired and retighten the grill. The filter is easy to remove/install, it can be removed to allow visual verification of the grill position.

- » If the air inlet grill is opened, the system will draw air mostly from inside the cab. This is the preferred position in summer.
- » If the air inlet grill is closed, the system will draw air mostly from outside the cab. This is the preferred position in winter.
- » To obtain the maximum efficiency of the air conditioning unit, keep the air grill behind the seat opened.

- » Adjust the cab air vents as desired for air circulation. The air vents are located on the ceiling liner and on the floor.

NOTICE

Do not direct a hot air flow from the air vents directly on a cold windshield or cold window. The difference in temperature could break the glass.

Do not block the grill with rags, gear or objects that could disrupt the air flow. Blocked air flow will prevent good ventilation and proper operation of the air conditioner.

Ensure the change of temperature on the windows is gradual.

TILT SENSOR

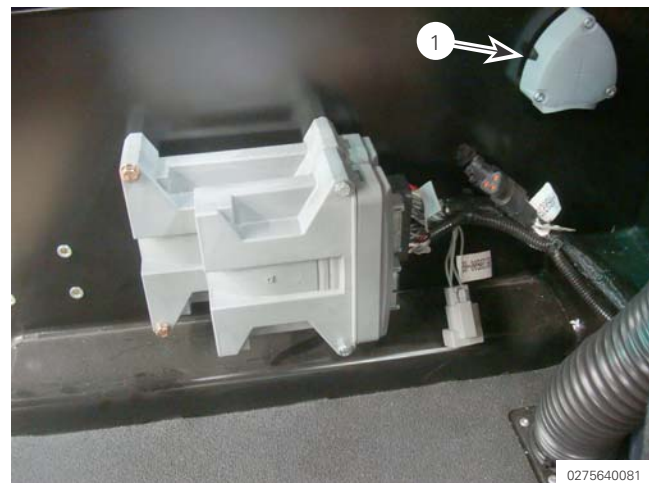

Figure 100

1. Vehicle tilt sensor

The tilt sensor will emit a warning sound when the vehicle reaches a pre-selected angle while riding on a slope. It helps the driver to be more vigilant, to better evaluate the steepness of the terrain and to select the best path for the vehicle.

The factory default setting for the slope indicator is:

- » Uphill/downhill: 15 degrees;
- » Sidehill: 15 degrees.

COMPONENTS INSIDE THE CAB

⚠ WARNING

Tip over hazard

Exceeding the gradeability of the vehicle could result in tip over. Equipment installed could lower vehicle capability. Remain vigilant when approaching critical angles and when the tilt sensor sounds.

If equipment is installed, it could lower the vehicle capability and the equipment itself may have limitations different from the ones of the empty vehicle. The equipment installer should ensure the tilt sensor is re-programmed if required.

DRIVER SEAT



Figure 101

1. Driver's seat (generic Panther shown)

⚠ WARNING

Crush hazard

Never adjust the seat position while driving as this may lead to loss of control causing injuries or death. Always adjust the seat when the vehicle is immobilized.

Ensure the operator is comfortable and can easily reach the controls in the cab once seated. Always adjust the seat **before** driving the vehicle.

The seat is equipped with a suspension system and the numerous adjustments:

Bottom cushion height adjustment



Figure 102

Height and angle adjustment lever

To adjust, pull up the adjustment lever and position the cushion as desired. Release the lever when done.

Back rest angle



Figure 103

Backrest angle adjustment lever

To adjust, pull up the adjustment lever and position the cushion as desired. Release the lever when done.

Weight adjustment (suspension seat)



Figure 104

Weight adjustment dial

To adjust, turn the dial according to body weight.

Fore and aft adjustment



Figure 105

Fore and aft adjustment handle

To adjust, pull up the adjustment handle and position the seat (fore-aft) as desired. Release when done.

Right armrest angle adjustment



Figure 106

1. *Roller for armrest angle adjustment*

Turn the roller underneath the right side armrest to adjust the angle.

Headrest height and angle adjustment



Figure 107

Headrest height

Pull the headrest up to the desired height. Tilt to change the angle.

Seat Storage Pocket

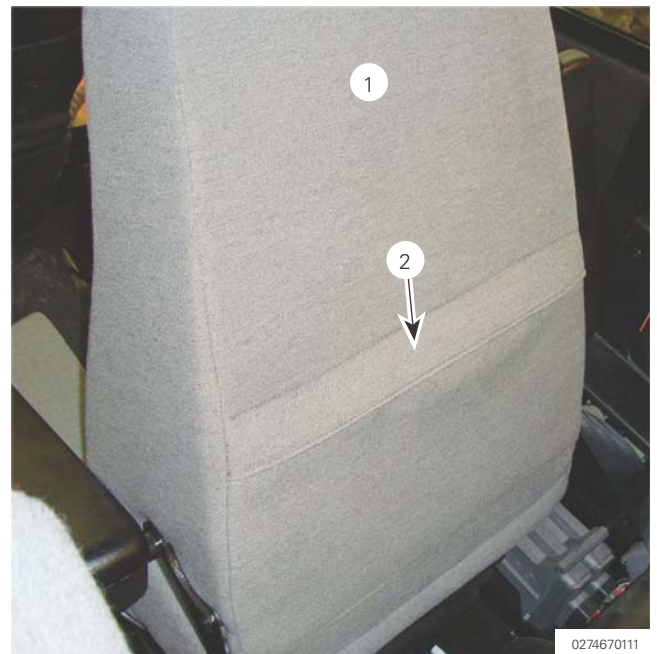

Figure 108

1. *Back of seat*
2. *Seat storage pocket*

The seat incorporates a storage pocket in its back. At the first delivery of the vehicle, the Operating and Maintenance Manual is located inside the rear pocket of the driver's seat.

COMPONENTS INSIDE THE CAB

SEAT BELTS



Figure 109

The seat is equipped with three point seat belt.

Ensure the belt is well adjusted:

- » The lap portion should be worn as low as possible on the hips;
- » The shoulder portion should fit snugly across the body. It should always be worn over the shoulder;
- » Ensure the belt is not twist on itself.

Use proper maintenance techniques:

- » Perform regular inspection on every parts of the belt system;
- » Never modify or disassemble the seat belt;
- » Never bleach, dye or use strong cleanser on the seat belts, chemicals can weaken them;
- » If seat in not working properly, see a PRINOTH authorized dealer for repair or replacement;
- » Inspect the belt, its anchor point and related components yearly. Replace at the first sign of damage or wear.

⚠ WARNING

Impact and crush hazard

The operator (and passenger if applicable) must wear the safety belt at all times. Failure to do so may result in severe injury or death.

The vehicle is capable of very short braking distance, especially when the parking/emergency brakes are engaged. Therefore the occupant must wear the seat belt at all times when riding the vehicle.

Never drive the vehicle with the seat belt buckled behind the driver to avoid wearing it and to bypass the safety system. Never modify the seat belt systems in any way.

The safety belt of the driver seat is equipped with a contact switch. If the safety belt of the driver is not fasten, then:

- » The transmission system is disabled and the brakes are applied;
- » A fault on the micro-controller cannot be cleared;
- » An warning icon will appear on the display;
- » If already in motion, the vehicle will stop.

If the vehicle was stopped because of an unfasten seat belt, it is required to return the transmission to the neutral point and release the speed pedal before a new drive command can be executed.

If the vehicle was involved in an accident and repaired, the seat belt, seat and cab should be inspected by trained personnel.

LEFT SIDE ARM REST

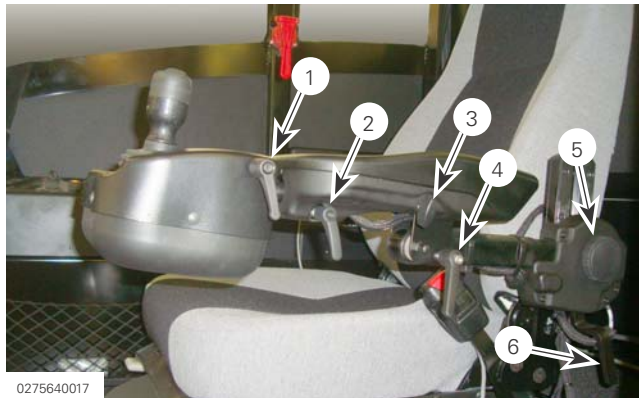

Figure 110

1. Locking lever for joystick support angle
2. Locking lever for joystick support length
3. Locking lever for armrest tilt angle
4. Locking lever for armrest angle
5. Locking knob for armrest height
6. Locking lever to unlock and raise the complete armrest

Use the adjustment levers and knob to get a comfortable position for the armrest. A position sensor will cancel all the functions of the joystick and the drive system when the armrest is raised.

NOTE : Rising the armrest is the equivalent of pressing the emergency stop switch. Dump body, frame rotation and drive system are disabled.

FIRE EXTINGUISHER



Figure 111

Fire extinguisher (North America model shown)

Refer to the “Safety Items inside the cab” section for details.

CAB ACCESSORIES

Cab accessories are provided for the comfort and safety of the operator. It includes the following:

- » Coat hook;
- » Radio speakers;
- » Handles to enter/exit the cab.

COMPONENTS INSIDE THE CAB

FIRST AID KIT



Figure 112
First aid kit

Refer to the “Safety Items inside the cab” section for details.

ESCAPE SYSTEM

Refer to the “Safety Items inside the cab” section for details.

MANUALS, TOOLS AND ACCESSORIES

Document case and literature



Figure 113
Document case with manual, USB flash drive and pen

The document case contains a paper version of the Operating and Maintenance Manual (present manual).

The Parts Catalogue of the vehicle is provided in an electronic format on the USB flash drive (the present manual is provided as well).



0274960027

Figure 114
USB flash drive

The files (in pdf format) can be consulted on a computer equipped with the Adobe® Reader® software. The software is available free of charge and can be downloaded from Adobe's web site.

Also in the document case is the Limited Warranty Policy Form, the Delivery Inspection Form and a pencil.

"Adobe® Reader® are either registered trademarks or trademarks of Adobe Systems Incorporated in the United States and/or other countries."

NOTICE

The USB flash drive is not write protected and thus the files it contains can be erased or deleted. It is recommended to make a backup copy of the files.

Tools and accessories

A terminal extractor is included with the vehicle to extract terminals from an electrical connector if needed for a repair, troubleshooting or installation of equipment.

Also with the vehicle is a key holder, a quick reference card (engine start procedure) and some hand tools.

EMERGENCY DRIVE MODULE

Figure 115
Emergency drive module

In the event of an emergency involving the failure of the steering wheel potentiometer, the transmission selector, the speed pedal potentiometer or the micro-controller, the emergency drive module can be used. **This module must only be used for an emergency return to base or to test the brakes. Do not use it under any other circumstance.**

⚠ WARNING**Collision hazard**

The emergency drive module does not provide the same precision as the steering wheel. The operator could lose control of the vehicle which may result in severe injuries or death. Read and understand all operation procedures before using the emergency drive module.

⚠ WARNING**Accident hazard**

If the vehicle is in the inverted configuration, the controls of the emergency drive module will be inverted. Use extreme caution when selecting the direction of motion.

Do not perform work with a partially disabled vehicle. Refer to the See “Using the Emergency Drive Module” on page 161 for instructions on how to use this device.

COMPONENTS OUTSIDE THE CAB

COMPONENTS OUTSIDE THE CAB

Some items or components shown in this section may be optional or installed only on vehicles intended for specific countries or regions.

BATTERY ISOLATOR SWITCH

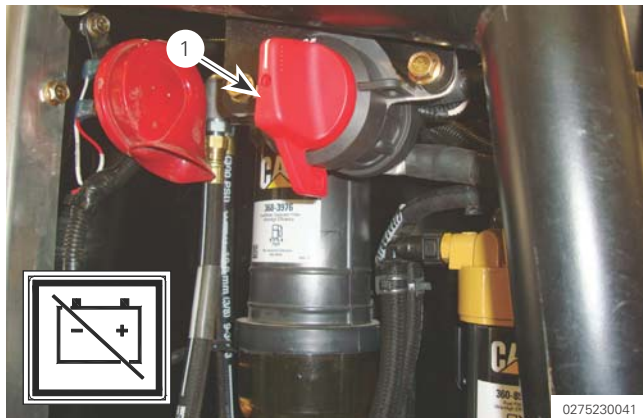

Figure 116

1. Battery isolator switch (in the "ON" position)

The battery isolator switch is located behind the front access panel of the cowling. The switch connects (ON) or disconnects (OFF) the negative poles of the batteries from the electric circuit of the vehicle. In the OFF position, a padlock can be installed to secure the switch setting. Its function is as follows:

- » Prevent a battery discharge during vehicle shipping or storage;
- » Protect service technicians from danger caused by inadvertent engine crank or start.

When turning ON the battery isolator switch, allow 30 seconds before switching ON the ignition.

Unless an emergency occurs, do not turn off the battery isolator switch if the engine is running. A voltage peak could damage electronic components.

If welding is performed on accessories attached to the vehicle, turn off the battery isolator switch AND disconnect the batteries.

Aftertreatment delay

NOTICE

WAIT 2 MINUTES before turning off the battery isolator switch after the engine shut down. If the battery isolator switch is turned off immediately, DEF/AdBlue® could be trapped in hoses and freeze in cold temperature, causing damage to the system components.

When turning OFF the vehicle ignition switch, allow 2 minutes before switching OFF the battery isolator switch. The PETU pump will operate for a short period following an engine shut down. This will empty the hoses to prevent freezing.

TRACK TENSION RELEASE KNOBS

The pressure relief buttons are located inside the cowling, behind the rear lateral access panel. One knob controls the right track tension, the other controls the left track tension.

When the small pin (1) is inserted in the notch, the knob is "pushed in" and the track will be under tension while the engine runs. See next figures.

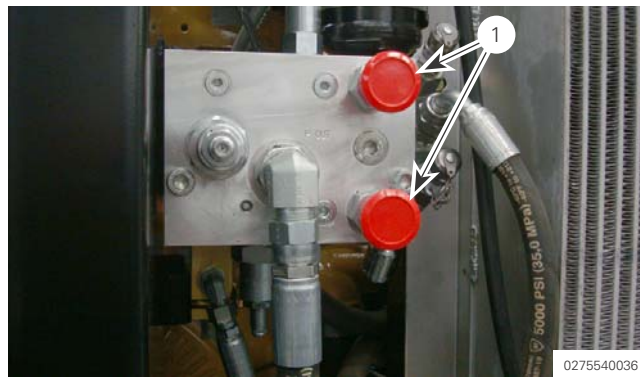

Figure 117

1. Track tension release knob

NOTICE

Turn off the diesel engine if the track tension is released. Leaving the engine running for more than a few minutes could cause permanent damage.

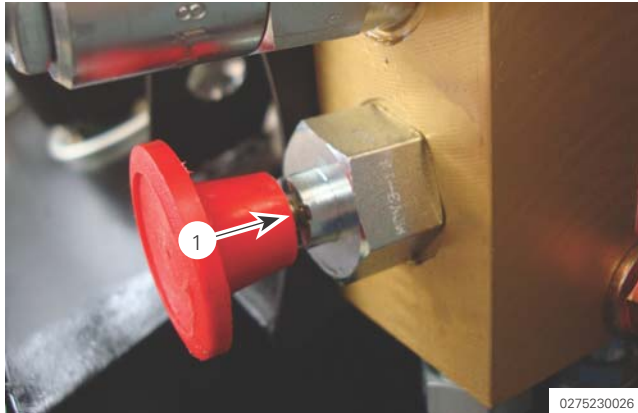

Figure 118

1. Pin inside the notch (track under tension)

When the small pin (1) is out of the notch, the knob is “pulled out” and the track will be NOT under tension while the engine runs. See next figure.

NOTE : To release tension, pull out the knob, then rotate it 90 degrees clockwise.

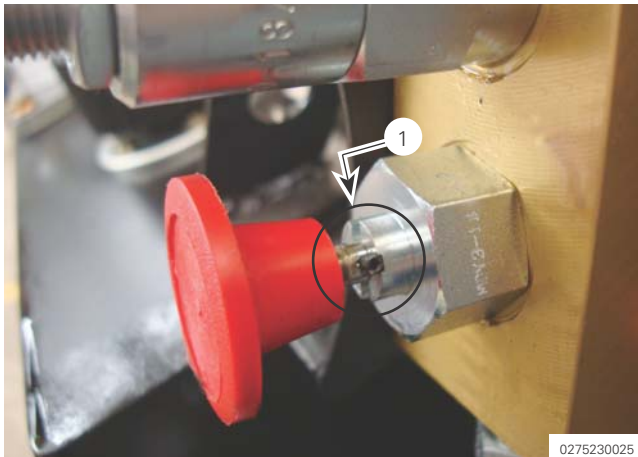

Figure 119

1. Pin outside the notch (track tension released)

Ensure the track tension release knobs are in the running position (“pushed in”) before driving the vehicle. Setting the vehicle in motion with loose tracks could lead to detracking.

Track tension adjustment is automatic once the diesel engine is running and the vehicle rides a short distance.

NOTE : Use these buttons to release track tension when lubricating the grease points of the tensioner crank arms or to facilitate removal of the sun gear when disengaging the planetary gearboxes.

FUEL FILLER CAP AND TANK



Figure 120

1. Fuel filler cap

The fuel tank filler cap is located behind the cowling on the vehicle left side. The cap is equipped with a lock and key. The lock uses the same key as the ignition switch.

⚠ WARNING

Explosion and fire hazard

Fuel is flammable and explosive under certain conditions. Always manipulate in a well ventilated area. Do not smoke or allow open flames or sparks in the vicinity of the vehicle. Do not operate the engine cooling heater while refueling. Failure to do so may cause injuries or death.

ENVIRONMENTAL PROTECTION : Spilling fuel could harm the environment. Refuel the vehicle on level ground, avoid overfilling.

Use fresh diesel fuel of the appropriate type when refuelling the vehicle. Observe following common safety practices when refuelling:

- » Always manipulate fuel in a well ventilated area;
- » Do not smoke or allow open flames or sparks in the vicinity of fuel;
- » Do not refuel if engine is hot or running;
- » Avoid physical contact with fuel;
- » Regularly inspect fuel system components;
- » Wipe up any spilled fuel;
- » If fuel or fumes are noticed while driving, cause must be determined and corrected without delay;
- » Never open the fuel lines or remove the injectors if the engine runs out of fuel.

COMPONENTS OUTSIDE THE CAB

It is recommended to fill the tank at the end of each day of operation. This helps to prevent moisture from collecting in the fuel system.

⚠ WARNING

Fuel under pressure

NEVER open fuel lines, the fuel rail or crack injectors to bleed the fuel circuit.

Injectors operate at very high pressure and could cause severe injuries or death. Use the priming pump to fill the fuel lines.

If the engine shuts down because it ran out of fuel, refill the tank and crank the engine. Do not crank for more than 2 minutes as this could cause permanent damage to engine components.

Ultra low sulfur fuel for Tier 4 engine

Ensure to use only ULSD (ultra low sulfur diesel) fuel with Tier 4 engine.

⚠ WARNING

Fire and explosion hazards

Avoid static electricity risk when refuelling. Ultra low sulfur diesel (ULSD) poses a greater static ignition hazard than diesel formulation with a higher sulfur content. Follow fuelling standards for proper grounding and bonding practices.

Take all necessary precautions when refuelling with ULS diesel fuel.

NOTICE

Do not run the engine with regular diesel fuel. Tier 4 engine must run on ultra low sulfur diesel (ULSD) fuel otherwise the engine may sustain permanent damage.

Ultra Low Sulphur Diesel (ULSD) with a maximum fuel sulphur level of either 15 or 20 ppm is required. Fuel sulphur levels in excess of 20 ppm will rapidly damage the diesel particulate filter (DPF) and diesel oxydation catalyst (DOC), likely resulting in the need to replace the aftertreatment unit. Damage to the DPF and/or DOC may impact emissions. Refer to "TECHNICAL DATA" on page 114 for information on the recommended fuel.

Bio-diesel fuel may be used up to B20 (80% standard ULSD with 20% bio-fuel dilution by volume), provided an appropriate approved additive is used, refer to engine supplier for the acceptable specification. Use

of a higher concentration will affect performance, durability and warranty conditions.

As bio-fuel is chemically more reactive than the mineral oil used in diesel fuel, it is imperative to consider the effects of this fuel on all components that it may come into contact with.

Obtain the advice from the your Prinoth representative if the use of bio-diesel is required.

Dual Fuel Tanks

The Panther T14R is equipped with two fuel tanks and a single filler neck.

When refuelling, ensure the quantity will fill both tanks to obtain the maximum driving range of the vehicle.

Rubber Blanket Between the Fuel Tanks

The rubber blanket installed between the fuel tanks provides a certain amount of protection against small rocks and dirt while the dump body is raised. Without the blanket, the cavity inside the bearing of the swing system would fill with unwanted material.

If removed, reinstall the blanket after maintenance. Replace if damaged or worn.

DEF/AdBlue® FILLER CAP



Figure 121
DEF/AdBlue® tank filler neck

The DEF/AdBlue® (Diesel Exhaust Fluid) tank and filler cap are located behind the access panel at the front of the right side cowling.

Keep the cap closed to prevent contaminant intrusion and evaporation of the fluid.

Use only DEF/AdBlue® (urea solution) compliant with the ISO 22241-1 standard. Fluid that does not meet this standard could damage the emission control system. Refer to “TECHNICAL DATA” on page 114 for information on the recommended fluid.

NOTICE

The operator should NEVER top off the DEF/AdBlue® tank. Fill until the nozzle stops flowing. Expansion from freezing temperature could damage the unit in case of overflow. Clean any spill since the DEF solution is corrosive.

The DEF/AdBlue® level in the tank is indicated on the cab LCD display. Engine power adjustment and eventual shut down will occur in the event of insufficient or poor quality DEF/AdBlue® supply.

DEF/AdBlue® solution is typically colourless and clear. Changes to colour or clarity are indicators of quality problems.

WATER SEPARATOR DRAIN VALVE



Figure 122
1. Fuel filter/water separator drain valve

The valve is located behind the access panel at the front of the right side cowling. To drain the water in the clear bowl of the water separator, turn the valve knob. Return the valve knob to its original position once all the water is drained.

HEATER CONNECTOR

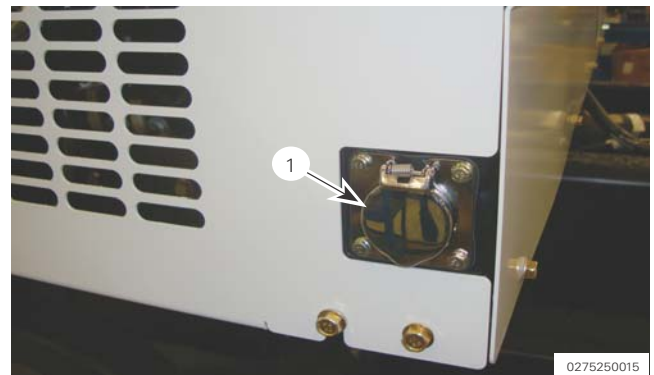

Figure 123
1. Heater connector

It is recommended to connect the heaters to an external electric power source for at least a few hours if the outside temperature drops below the freezing point. This will ease engine start, shorten time to set in motion and reduce wear on several components.

The vehicle heater connector is located behind the door, on the left side of the cab. Electric heaters are located in the engine block (to warm the coolant fluid) and in the hydrostatic oil reservoir.

COMPONENTS OUTSIDE THE CAB

NOTICE

Remember to disconnect the vehicle from the external power source before starting and getting the vehicle in motion.

Power cord for heater connector

Heaters on the vehicle are either 120 or 240 volts. The vehicle electrical connector for the external power source is of North America type.

In North America, use a standard power cord.

In other parts of the world, proceed as follows to modify a power cord:

NOTE : Ensure the voltage rating of the external power source is the same as the voltage rating of the heaters.

The power cord is not supplied with the vehicle.

- » Find a power cord with the proper connectors for the external power source;

NOTICE

Follow all applicable standards for electrical cords or devices.

- » Cut and remove the female connector of the power cord and reconnect the wires to the supplied female connector. See the following figure for polarity.

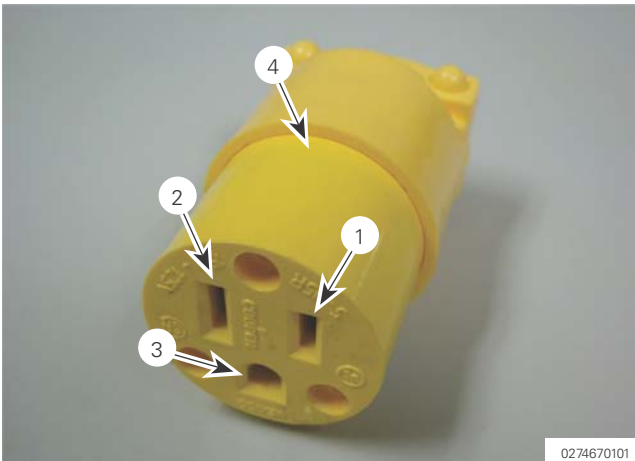

Figure 124

1. L1 - Positive
2. L2 - Neutral
3. Protective earth - ground
4. Female connector for power cord

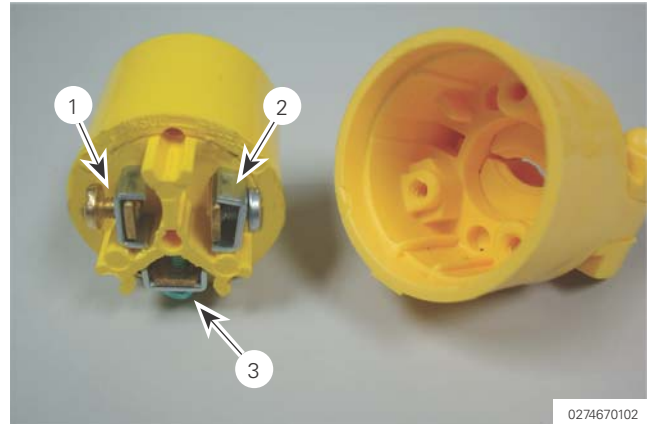

Figure 125

1. L1 - Positive (gold screw)
2. L2 - Neutral (silver screw)
3. Protective earth - ground

- » With the modified power cord, connect the female connector (shown here) to the vehicle and the male connector to the external power supply.

NOTICE

Fire hazard

A power cord with an insufficient rating could overheat and cause a fire. Always select a power cord as short as possible and with a capacity higher than the combined heaters.

Use the following power requirement to calculate the rating of the power cord according to its length:

- » With 240 volt heaters: about 5 amperes,
- » With 120 volt heaters: about 10 amperes.

FUEL HEATER

If installed, the fuel heater is incorporated to the primary fuel filter. Operation is automatic and the unit is maintenance free.

WINDSHIELD WASHER FLUID RESERVOIR



Figure 126

1. Windshield fluid tank

The windshield washer reservoir is located inside the engine compartment. The reservoir supplies fluid to the front and rear windows.

HYDRAULIC OIL LEVEL SIGHT GLASS

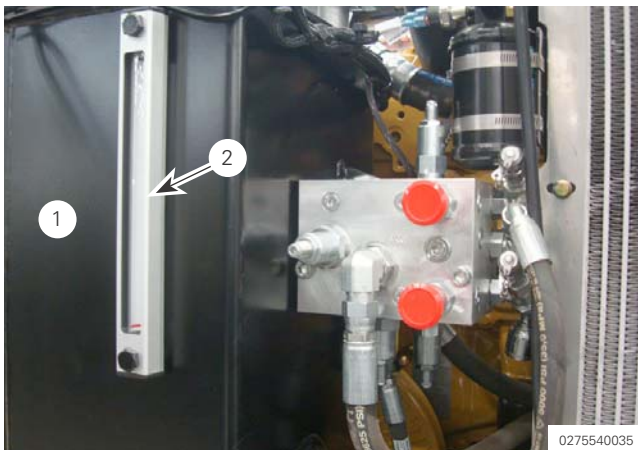

Figure 127

1. Hydraulic reservoir
2. Hydraulic oil level sight glass

For a quick verification, the oil level sight glass is visible through the cavity in the rear cowling.

EXTERIOR MIRRORS



Figure 128

1. Left side exterior mirror

The exterior mirrors can be adjusted manually.

Convex mirrors, if installed, provide a wider viewing angle for the driver.

REAR VIEW CAMERAS



Figure 129

Exterior camera with low light capability

There are two rear view cameras. One is located below the right side mirror, the other is located under the rear end of the dump body.

Use the camera to enhance dumping precision and as additional viewing angles to detect potential obstacles.

Keep the lens clean on both cameras to ensure a clear image on the monitor in the cab. Do not clean with strong chemical. Wipe carefully with a damp cloth.

COMPONENTS OUTSIDE THE CAB

The cameras are equipped with infrared LED night vision system and heating elements to provide low temperature operation.

ROOF GRILL (FOPS)



0274670156

Figure 130
Roof FOPS structure

A grill adapted to the curve of the roof may be installed over the cab to conform with the FOPS (Falling Objects Protective Structure) standard. It is designed for areas where falling objects pose hazards to the occupant in the cab.

⚠ WARNING

Crush hazard

Altering the roof grill structure (FOPS) could reduce its resistance to falling objects and cause severe injuries or death. Do not modify the grill and its attaching hardware in any way.

Never install a grill and attaching hardware other than the genuine PRINOTH parts. Refer to the label in the cab for information on the FOPS.

BRUSH GUARD

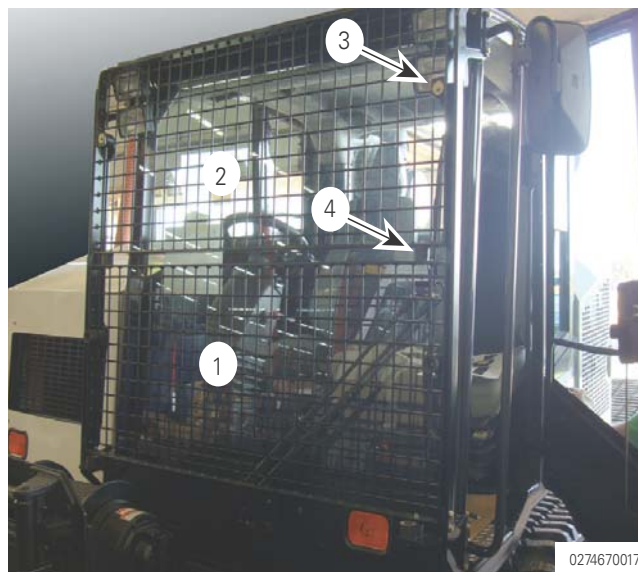

0274670017

Figure 131

1. *Brush guard lower section*
2. *Brush guard upper section*
3. *Upper fastener*
4. *Lower fastener*

The front brush guard is divided in two removable sections (to provide better visibility if protection is temporarily not required). The sections are identical except for some of the fasteners. The top section can be stowed ("snapped") in front of the bottom section.

To remove the top section, pull it forward to disconnect the top fasteners (item 3 on previous figure). Then, pull the unit up to disconnect the lower fasteners (item 4). Store the section in a suitable location or relocate it in front of the bottom section.

DUMP BODY



Figure 132
Vehicle equipped with a dump body

The Panther T14R dump body has a raised tail end. Use the joystick in the cab to operate the unit. Refer to the section describing the dump body operation for details and safety precautions.

Dump body safety rod

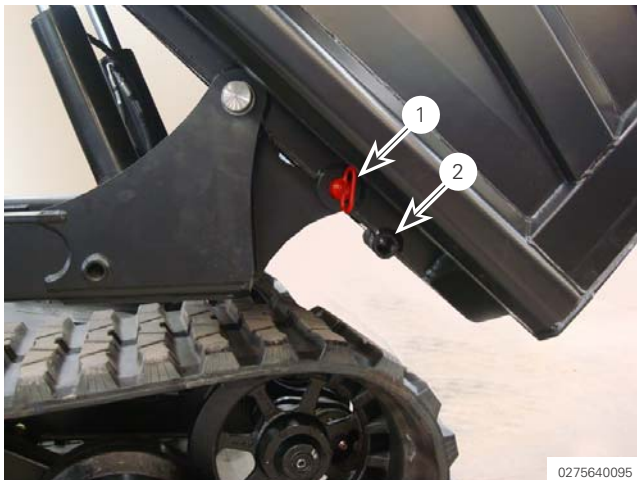

Figure 133
1. Safety rod in the locked position
2. Cavity for stowage of the safety rod

Refer to the section covering the dump body operation for details and safety precautions.

COWLING ACCESS PANELS AND OPENINGS

There are several access panels on the cowling. Refer to the following for location and description

⚠ CAUTION

Burn hazard

Opening the engine cowling access panels or reaching in access holes of the cowling exposes hot components that can cause severe burns. Stop the diesel engine and let it cool down before opening access panels or reaching in the access holes of the cowling.

Ensure all access panels are closed and secure when operating the vehicle. Ensure the grills allow free air circulation (air and coolant radiator, oil cooler and cab).

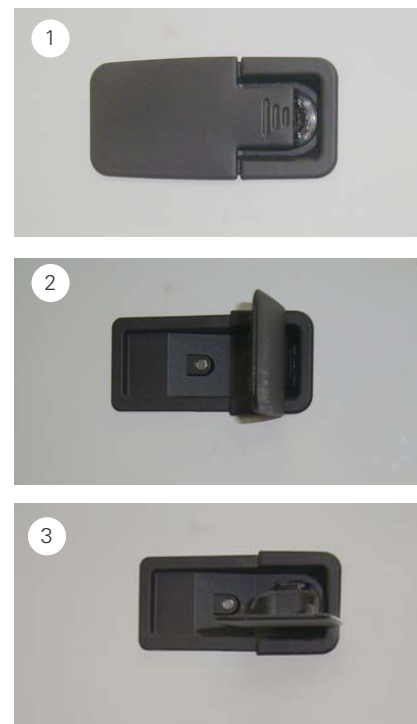

Figure 134
1. Latch closed
2. Pull out the flap
3. Rotate the flap 90 degrees clockwise to open

Some of the access panels require the vehicle key to open, some use the latch shown on the previous figure.

COMPONENTS OUTSIDE THE CAB

The latches of the access panels can be slightly adjusted. For a tighter fit, screw in the inner nut and then the outer nut. To loosen, perform the opposite. Use thread locking fluid to prevent loosening. See next figure.



Figure 135
Access panel latch
1. Inner nut
2. Outer nut

The top access panels are attached using a rubber fastener that can be accessed by the nearest lateral panel. See next figure. One panel requires the vehicle key to open.

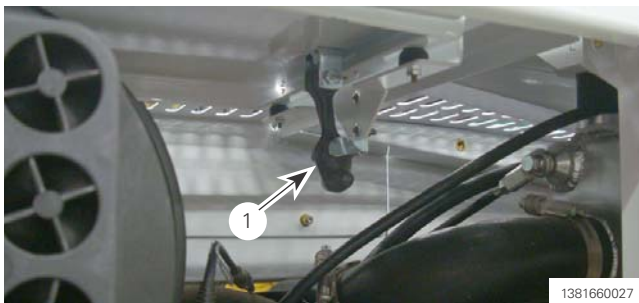

Figure 136
1. Rubber panel fastener

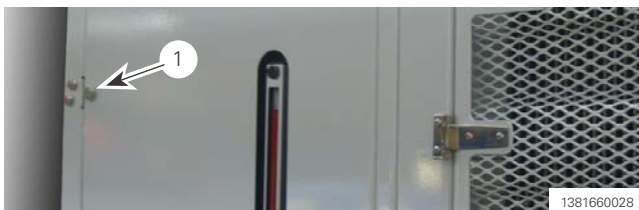

Figure 137
1. Key lock

Some of the access panels require the vehicle key to open.



Figure 138
Lateral right side access panel (rear) - engine oil dipstick, oil tank filler neck and sight glass, engine air filter, windshield washer fluid tank and track tension release buttons (rubber track vehicle)



Figure 139
Center lateral right side access panel (access to radiators and cooler for cleaning)



Figure 140
Lateral right side (front) access panel - DEF/AdBlue tank, water separator, secondary fuel filter and battery isolator switch.

STEPS AND GRAB HANDLES

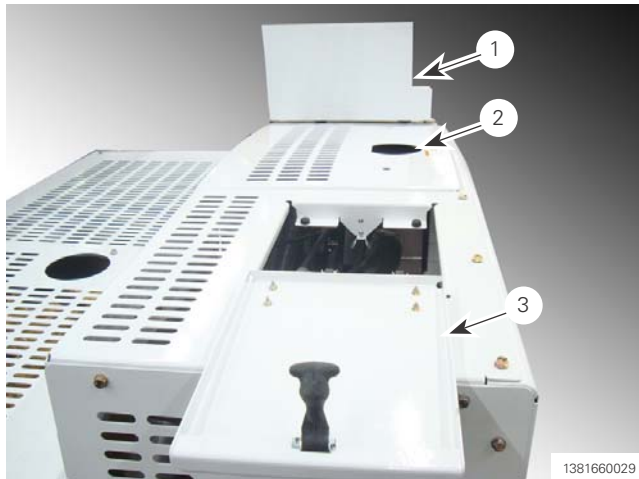

Figure 141

1. Front access panel
2. Cut out for radiator filler cap
3. Rear access panel

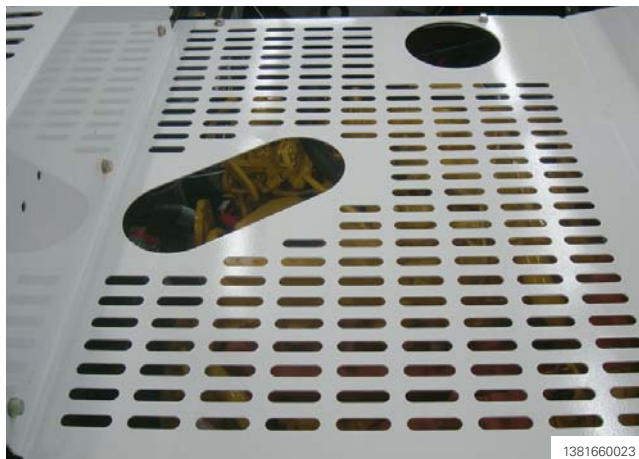

Figure 142

Cut out to access the engine oil filler neck and the transfer case oil dipstick (oblong cut out) and the engine crankcase breather oil filter (round cut out)

All other cowling panels of the cowling are bolted.



Figure 143

1. Step (toothed ring) to enter/exit the cab - on sprocket
2. Auxiliary step - on idler wheel (if vehicle is inverted)

Use the larger toothed ring (item 1 on previous figure) on the sprocket to enter or exit the cab. The smaller toothed ring (item 2 on previous figure), on the idler wheel, should be used only as an auxiliary step if the vehicle is inverted.

There are two grab handles on the cab, one for each hand. To avoid a fall, use the three point rule to enter the cab. Always face the vehicle when entering or exiting the cab.

When exiting, always face the vehicle, grab both handles and ensure to put a foot on the track and then on the notched ring before releasing one of the handles.

Always keep the handles free of dirt, oil, grease or mud. Slipping on these items may cause injuries.

NOTE : The three-point system means three of your four limbs are in contact with the vehicle at all times: two hands and one foot, or two feet and one hand.

COMPONENTS OUTSIDE THE CAB

BEACON LIGHT

If installed, the beacon light is located on top of the cab and is activated by a switch located on the overhead console.

“D” RINGS

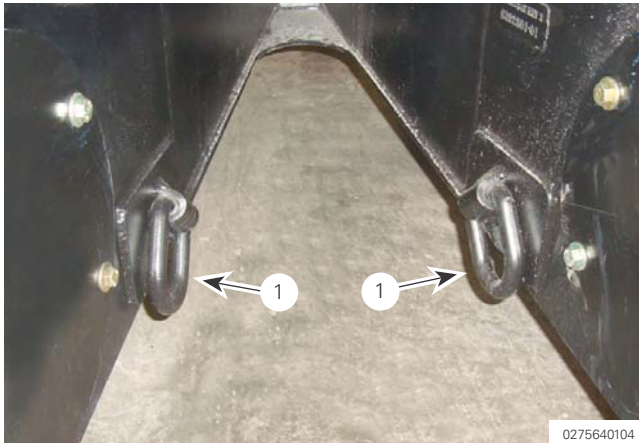

Figure 144
1. “D” ring

⚠ WARNING

Crush hazard

Never use the “D” rings to lift, move or tow the vehicle. It could sustain damage, move unexpectedly, turn over or crash, causing severe injuries or death.

The “D” rings are to be used only to tie down the vehicle during transport on a flatbed, in a container, or other. Two “D” rings are provided at the front of the vehicle. At the back, use the round beam to chain the vehicle.

LUBRICATION PORTS



Figure 145
Grease fittings

Lubrication ports for some of the components are located at the back of the vehicle. Refer to the “Maintenance Schedule” section for information on the lubrication intervals. Refer to the “Lubrication” section to locate components to be lubricated.

DRAINING HOSE FOR HYDROSTATIC TANK

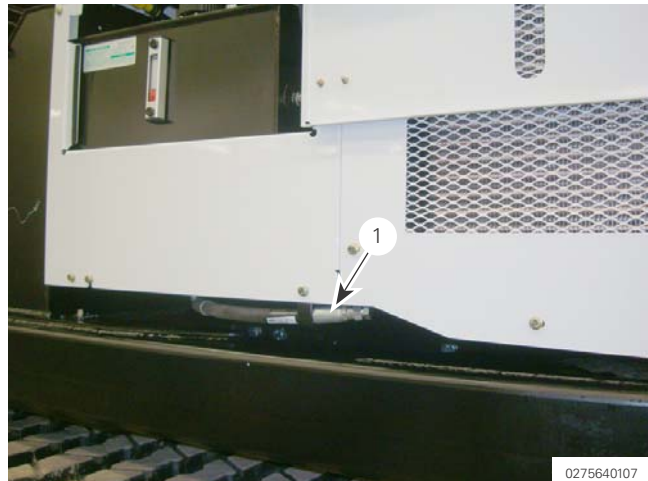

Figure 146
1. Hydrostatic tank draining hose

Use the hose shown in the preceding figure to drain the hydrostatic tank. Using the hose enables oil change without removing the cowling panel.

PRE-OPERATION INSPECTION

INSPECTION BEFORE STARTING THE ENGINE

Ensure all fluid levels are checked when the vehicle is on a flat and level surface. A cool engine and components will reduce burn hazard.

If a fluid low level is noticed, top off while observing recommendations in the “GENERAL MAINTENANCE GUIDELINES” section. If a low level is observed in a repetitive fashion, report the problem to the maintenance personnel.

ENGINE OIL LEVEL

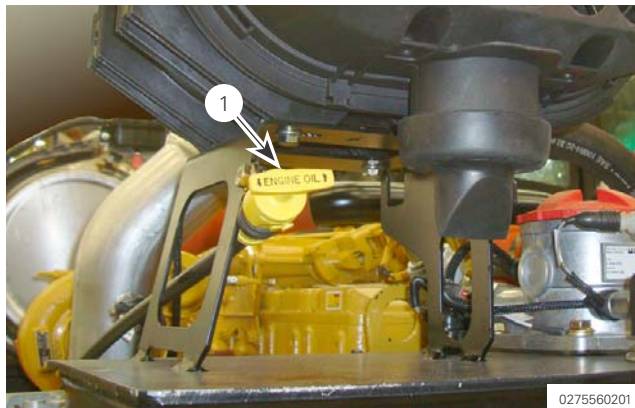

Figure 147

1. Engine oil dipstick

Check oil level daily when the engine is cool. To access the oil dipstick, open the rear access panel on the right side of the cowling. To unlock the dipstick, push the handle and turn it a quarter of a turn counter-clockwise.

The oil level should always remain within the marks on the dipstick.

Allow 10 minutes between engine stop and oil level check.

Top up with recommended oil if level is low. The filling cap is located on the top of the engine valve cover.

ENGINE COOLANT LEVEL

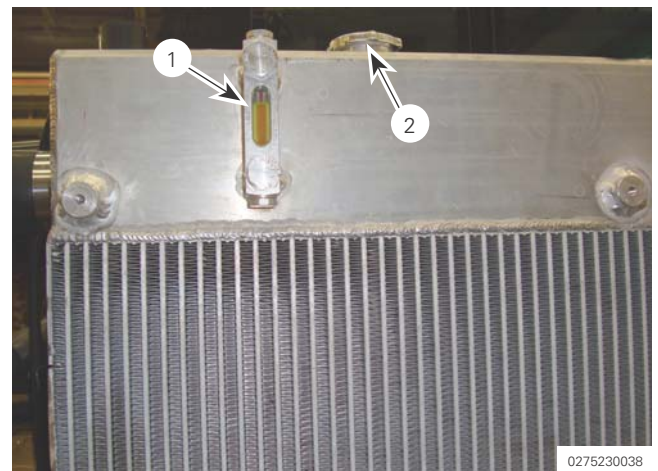

Figure 148

1. Engine coolant and fluid sight glass
2. Coolant reservoir cap

⚠ WARNING

Burn hazard

Never remove the coolant reservoir cap when the engine is hot. To avoid severe burns, do not inspect the coolant system or attempt to add coolant if the engine is hot.

Check engine coolant level daily. The engine coolant reservoir, sight glass and cap are located on top of the coolant radiator.

At ambient temperature (cold fluid), the coolant level should reach the “full” mark on the sight glass.

Ensure the coolant temperature is cool before checking the level. Top up with recommended fluid if level is low.

PRE-OPERATION INSPECTION

HYDROSTATIC OIL LEVEL



Figure 149

1. Hydraulic reservoir
2. Hydraulic oil level sight glass

Check oil level daily on the sight glass which is visible in the oblong cutout at the rear of the cowling.



Figure 150

1. Cut out for hydraulic oil sight glass

The oil level should reach between the "low" and "full" marks on the sight glass. If tracks are loose, double check oil level when the engine is running and tracks are under tension. If equipped, the dump body should be in lower position.

Top up with recommended oil if level is low.

NOTE : Retraction or extension of any cylinder on the vehicle will change the quantity of oil in the reservoir.

FUEL FILTER / WATER SEPARATOR



Figure 151

1. Drain valve of the fuel filter/water separator

Check for presence of water daily (according to the local conditions). The fuel filter is located behind the front access panel of the cowling.

ENVIRONMENTAL PROTECTION : Spilling fuel could harm the environment. Use a recipient to collect water and fuel, stop drainage as soon as the clear bowl is empty of water.

If water is detected in the clear bowl, position a recipient under the valve and turn the valve knob to drain the water. Return the valve knob to its original position once water is drained.

NOTE : Water is heavier than fuel and will flow to the bottom of the clear bowl.

PUMP DRIVE OIL LEVEL

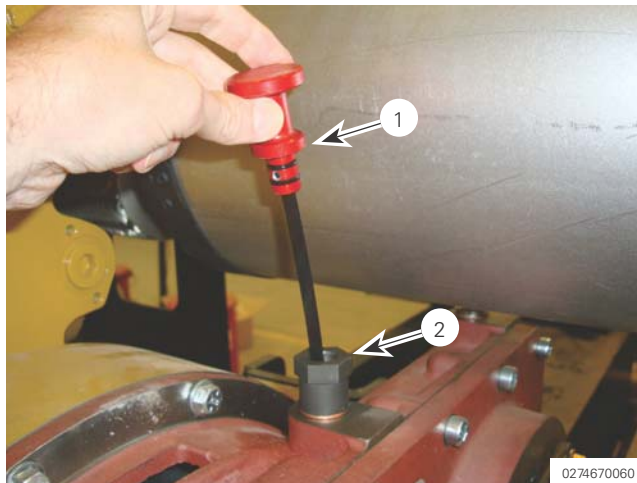

Figure 152

1. Oil level dipstick
2. Dipstick receptacle on pump drive

- » Pull it out again and check the level;
NOTE : The level must be between the marks of the dipstick at ambient temperature. Top up with recommended oil if level is low.
- » Insert the dipstick in its receptacle completely.100

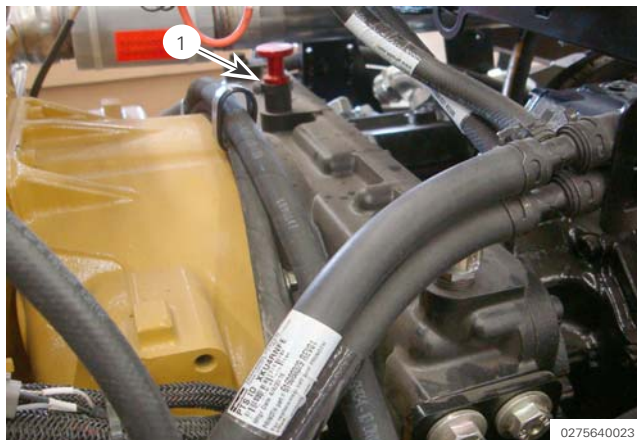

Figure 153

1. Oil level measurement position

⚠ CAUTION

Burn hazard

The oil level dipstick is located close the muffler which becomes hot during operation. Take precautions when pulling out and re-inserting the dipstick if muffler is hot.

Check oil level daily. Access the oil dipstick from the access hole at the top of the cowling.

To check the oil level perform the following:

- » Pull out the dipstick;
- » Using a clean rag, wipe oil from the dipstick;
- » Insert the dipstick in the receptacle, push the dipstick completely in (see previous figure);

PRE-OPERATION INSPECTION

PLANETARY GEARBOXES OIL LEVEL

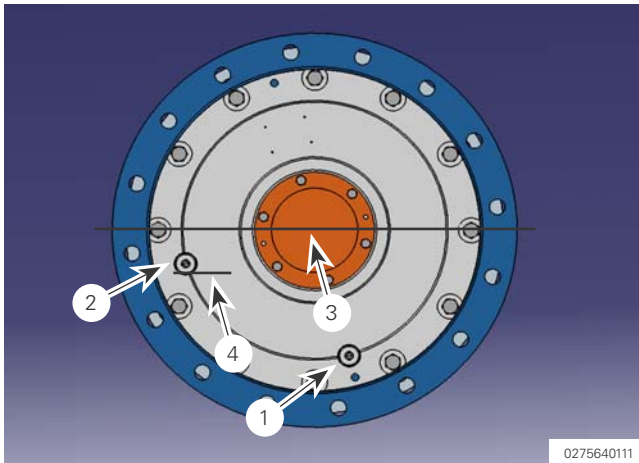

Figure 154

1. Fill / drain plug
2. Level plug
3. Imaginary housing center line (align with bolts)
4. Recommended oil level

Check oil level on both planetary gearboxes on a 50-hour basis.

Rotate the planetary gearbox to position the drain plug and level plug as shown on the previous figure. Ensure the imaginary horizontal line is aligned with the bolts at the circumference (as shown).

Re-adjust level with the recommended oil if required. Ensure no foreign matter enters the housing as contamination could cause irreversible damage. Do not overfill as this could lead to overheating and cause permanent damage.

NOTE : Replace the brass washer of the plug at every removal.

WINDSHIELD WASHER FLUID LEVEL



Figure 155

1. Windshield washer tank

Check fluid level on a daily basis. Access the reservoir from the access panel on the right side of the power pack cowling. Top up as required with standard windshield washer fluid.

TRACK AND UNDERCARRIAGE CONDITION



Figure 156
Track and undercarriage (generic Panther shown)

Before operating the vehicle, check track and undercarriage condition on a daily basis:

- » Check track general condition;
- » Check track rubber for wear (see next figure);
- » Check track rubber for cracks, delamination or local damage. Check also for cuts, chuncking, punctures or exposed cables;
- » Check track guides for wear and damage, check for missing track guides;
- » Check wheels, idler wheels, top rollers and sprockets for wear and damage;
- » Check lubricant level on wheels, idler wheels hubs and top roller hubs on a 50-hour basis.
- » Check sprocket condition and wear.

Material that is abrasive or sticky like clay, mud or gravel should be cleaned from the undercarriage to minimize component wear.

Corrosive material (fuel, DEF/AdBlue®, oil, salt, fertilizers and others) can corrode the metal embedded in the rubber track. flush with clean water at beginning and end of each work shift.

Track wear

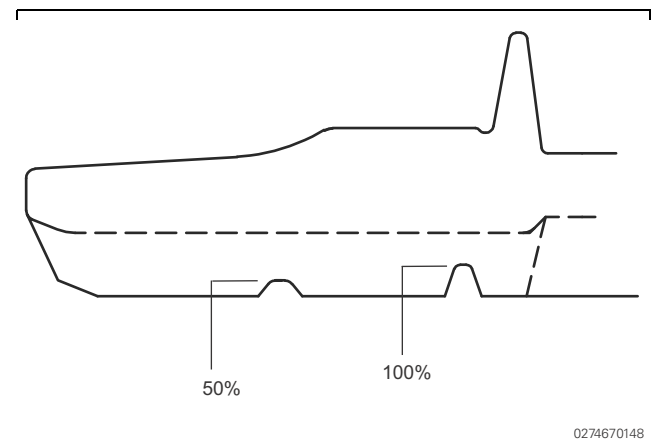

Figure 157
Track wear indicators (outer groove 50%, inner groove 100%)

The outer groove from the center of the track indicates 50 percent wear of the thread pattern. The inner groove indicates 100 percent wear and mandatory track replacement.

Depending on the traction requirement for the vehicle, replacement of the track should be carried out between the 50 and 100 percent wear.

Replace the track when the 50 percent wear mark is reached to keep maximum traction. When traction is not critical or when the vehicle travels mostly on level ground, replace the track later but not past the 100 percent wear mark. If the track is kept past the 100 percent wear mark, traction will be minimal and the track will slowly destroy itself, possibly damaging the undercarriage components at the same time.

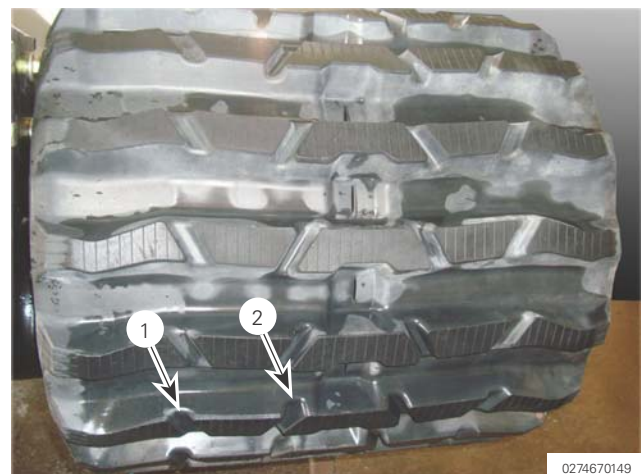

Figure 158
1. Outer track wear indicator (50% wear)
2. Inner track wear indicator (100% wear)

PRE-OPERATION INSPECTION

OIL LEVEL IN WHEEL HUBS AND ROLLER HUBS

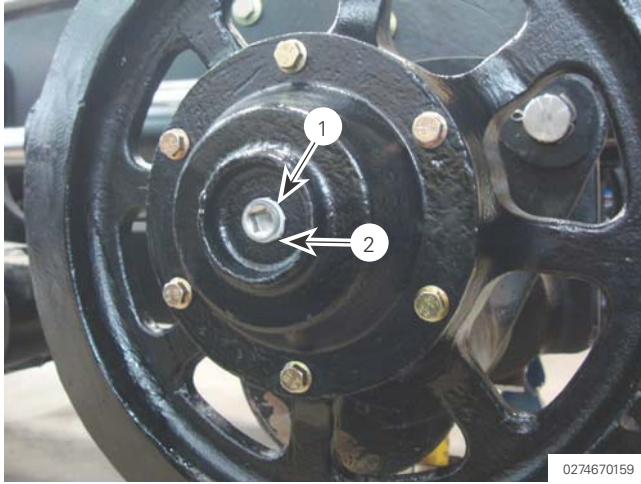

Figure 159

1. Wheel hub center plug (idler wheel hub shown)
2. Recommended oil level

Check oil level every 50 hours in wheel hubs, idler wheel hubs and top roller hubs. To do so, remove the center plug. The oil surface should be visible in the cavity. Add oil if required. Clean the plug and re-install it with a sealing compound. Ensure no foreign matter enters the cavity.

NOTE : The center plug is magnetic. When removed, inspect it for large metal particles. If present, it could indicate a problem.

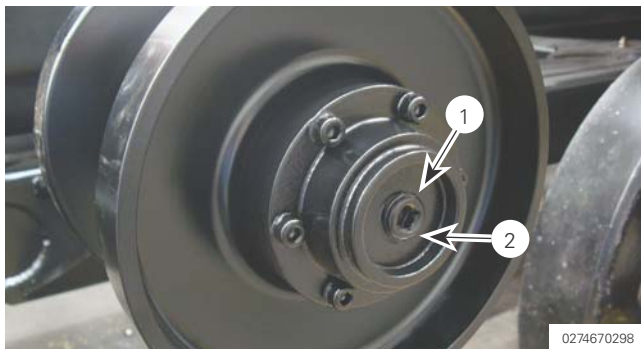

Figure 160

1. Top roller hub center plug
2. Recommended oil level

LUBRICATION

Lubrication is an important part of the pre-operation inspection/lubrication routine.

Refer to “Lubrication” in the “MISCELLANEOUS MAINTENANCE” section for the location of grease points and frequency of lubrication.

WALK AROUND CHECK

Check the vehicle carefully for the presence of dead leaves, pine needles, waste paper, grease, oil, or other flammable material around the batteries, muffler, or other component that reach high temperature. These could cause fire.

Check for leaks of oil or fuel from hoses and check for spills on the ground.

Check for abnormal situations like missing bolts, nuts connecting pins, hanging electrical wires, connectors or suspicious bulges on hydraulic hoses.

Correct these problems before operating the vehicle.

SAFETY EQUIPMENT

Verify safety equipment condition and presence in the cab:

- » fire extinguisher;
- » Removable rubber strip with the triangular tag on the windshield edge;
- » first aid kit;
- » emergency drive module.

SAFE WORK ENVIRONMENT

Always perform the following tasks to keep the vehicle clean and safe:

- » keep the cab floor and grab handles clean to prevent slipping and falling;
- » do not leave tools or parts lying on the floor or loose in the cab, they could become flying objects in case of emergency stop;
- » remove wood chips, debris, grass, oil or flammable material to eliminate the risk of fire;
- » remove mud or rocks stuck in the tracks that could cause injuries or damage.

INSPECTION AFTER ENGINE START

Perform the following verifications while the engine runs.

FUEL LEVEL



Figure 161
Fuel level on the display

Once the engine is running, check the fuel level on the display main screen. Check before operating the vehicle.

DEF/AdBlue® LEVEL



Figure 162
DEF/AdBlue® level on LCD screen

Once the engine is running, check the DEF/AdBlue® level on the display main screen. Check before operating the vehicle. Refill as required.

HYDROSTATIC OIL LEVEL

Double check the oil level when the diesel engine is running. Ensure the oil level is correct when the track tensioning cylinders are extended.

BACKUP ALARM AND PARK BRAKE VERIFICATION

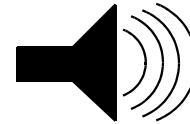

The back-up alarm activates automatically when the vehicle moves in the direction of the dumping edge of the dump body. Additionally, the alarm will sound when the upper frame of the vehicle is in rotation.

⚠ WARNING

Impact and crush hazard

The back-up alarm must operate when the vehicle moves in the direction of the dumping edge of the dump body and when the upper frame rotates. If the alarm fails, severe injury or death may occur to bystanders.

Ensure the backup alarm functions normally before operating the vehicle.



Ensure the parking brake operates normally before riding the vehicle. On the display, the (P) icon indicates that the brake has been applied with the emergency brake button. The (A) icon indicates that the brake has been applied automatically by the microcontroller (vehicle immobilized a few seconds, safety belt unbuckled, etc.).

LIGHTS

Check light operation prior to start the work shift.

PRE-OPERATION INSPECTION

TRACK TENSION



Figure 163
Normal track tension (generic Panther shown)

⚠ WARNING

Accident hazard

The vehicle loses its braking ability and is more prone to detracking when the tracks are loose. Braking problems could cause accident and injuries to the operator or bystanders. Ensure the tracks are under tension before driving.

Check track tension before operating the vehicle. To check track tension, ensure the brake is applied, the engine is running and the tension release buttons are in the “in” position (pressure applied).

The top section of the track above the top roller should be straight, no sag in front or behind the roller. Ensure track tension is the about the same on both sides of the vehicle. While driving, remain vigilant.

The track tensioning system is designed to apply the appropriate tension automatically as soon as the engine runs. A lack of tension is likely to be caused by a “pulled out” track tension release buttons, a hydraulic failure, a mechanical problem or a foreign object in the undercarriage. Do not drive the vehicle if one or both tracks are not under tension.

Air trapped in the tensioning cylinders could contribute to loose tracks, bad performance and even detracking.

CLOGGED FILTER INDICATOR



Figure 164
Clogged filter indicator

Check the clogged filter indicator gauge while the engine is running and the dump body is in operation. The filter is installed on the oil return line to the tank.

Replace the filter as soon as the needle reaches the red zone on the dial or replace at the same time as the other hydraulic filters, whichever comes first.

Replacing the filter may introduce air in the hydraulic circuit. Refer to the proper maintenance documentation to purge the air.

ENGINE STARTING AND SHUTDOWN

STARTING THE ENGINE

⚠ WARNING

Hazardous gases

A running engine produces hazardous gases. Never run the engine in an enclosed space. Open a window and ventilate the cab if running the engine at idle for long periods outside.

NOTICE

Never use ether or other non-approved external starting aid. Using such fluid or device could damage the engine or its sub-systems.

In cold weather, connect the heaters to an external power source prior to engine start.

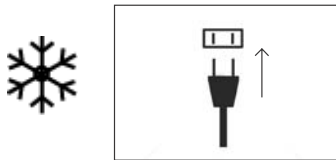

To start the engine, perform the following:

- » Apply the parking brake;

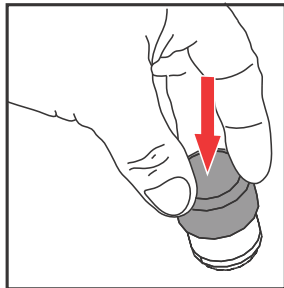

0274670129

- » Set the engine RPM to the minimum;

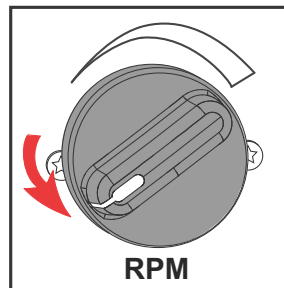

0274670131

- » Set the transmission to Neutral;

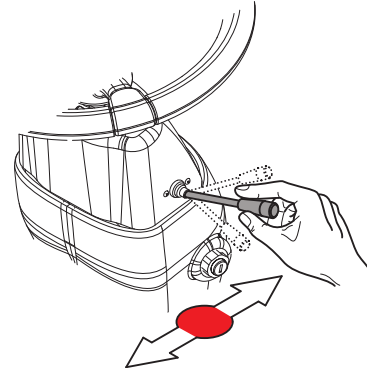

0274960083

- » Insert the key in the ignition switch and turn it to the "RUN" position.

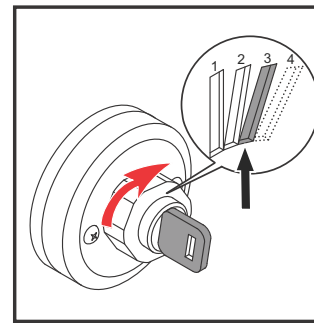

0274670132

- » In cold weather, wait until the "heater" icon disappears from the LCD display.

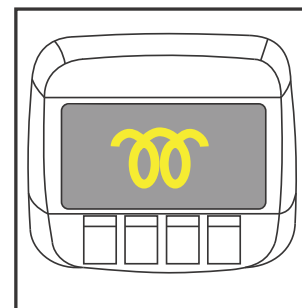

0274670133

- » Once the "heater" icon has disappeared, turn the key to the START position. Release once the engine runs.

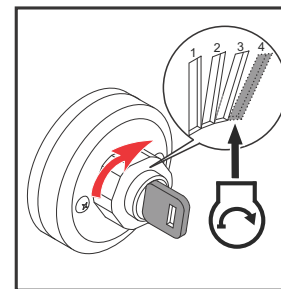

0274670134

ENGINE STARTING AND SHUTDOWN

NOTICE

Holding the key in the “START” position when the engine is running will damage the starter. Additionally, to avoid overheating, do not operate the starter for more than 30 seconds at a time and allow 120 seconds minimum between each operation.

NOTE : From the “Off” position, the key will go only once all the way to the “Start” position to prevent starter damage. If the engine fails to start the first time (at the “Start” position), return the key to the “Off” position and repeat the operation.

Cold Weather Start Procedure

Prior to starting the engine, use electric block heater and hydraulic oil heater or engine pre-heater if available/installed. Disengage any driven equipment, minimize or eliminate any inessential electrical loads.

Do not forget to disconnect electric power cord **before** getting the vehicle in motion.

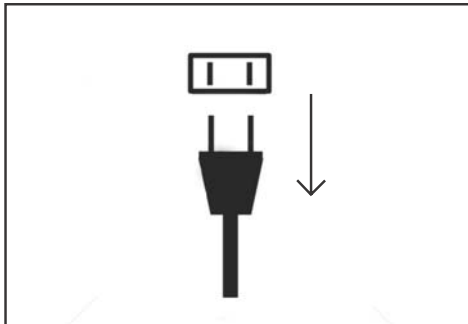

0274670175

Figure 165

Cold weather start procedure is not different from the sequence used in mild or warm temperature. Engine cranking may take longer as well as time to reach normal operating temperature. Allow at least 120 seconds between starter cycles. When the engine runs, proceed slowly at first and do not load the engine and vehicle too quickly.

SHUTTING DOWN THE ENGINE

WARNING

Accident hazard

Never shut down the engine while the vehicle is in motion. Loss of control could occur. Stop the vehicle completely and apply the parking brake before shutting down the engine.

Stopping the engine applies the brakes instantly. Ensure the vehicle is immobilized before shutting down the engine.

NOTICE

Engine and lubricant life will be shortened if the engine is not properly cooled before shutdown. Allow the engine to run at idle speed for five minutes to allow a gradual and uniform cooling.

Before shutting down the engine, perform the following:

1. Perform a complete stop of the vehicle;
2. Set the transmission lever to the neutral position;
3. If not already done, deactivate the equipment (if installed);
4. Engage the parking brake;
5. Turn rpm to idle to cool down the turbo. Let the engine run at idle for a few minutes.
6. To stop the engine, turn the key in the ignition switch to the "off" position.
7. If it is required to turn off the battery isolator switch, wait two minutes to allow the aftertreatment unit to shut down.

NOTICE

The engine may be damaged and warranty declared void if the battery isolator switch is turned off before the required delay.

DRIVING INSTRUCTIONS

DRIVING INSTRUCTIONS

SETTING THE VEHICLE IN MOTION

NOTE : In cold weather, allow the engine to run at idle speed for about 10 minutes before operating at full load.

NOTE : Remember to disconnect the vehicle from the external power source before starting and getting the vehicle in motion.

- » Fasten the seat belt;

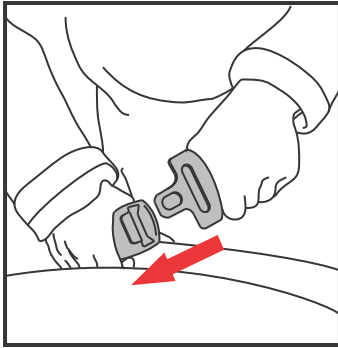

- » Ensure the transmission lever is in neutral;

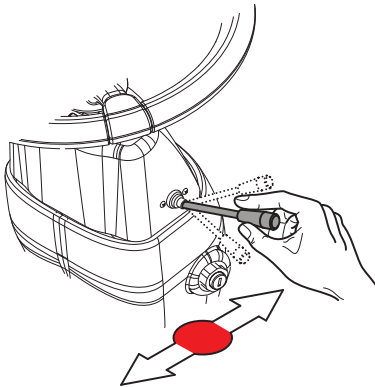

- » Ensure the left armrest is down;

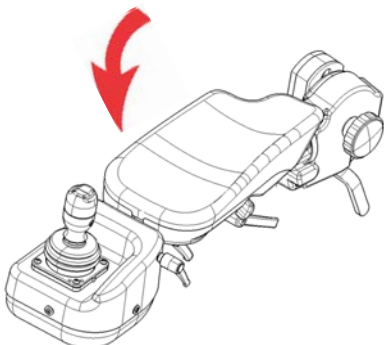

- » Leave the engine speed control knob at the minimum setting or set a higher engine speed if desired (maximum is 1400 rpm);

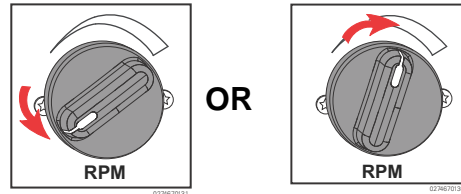

NOTE : Keep the lower setting is for normal driving. Higher setting will provide higher torque, for example when immobilized and getting out of a mud hole or starting on a steep incline. Use when power is more helpful than speed.

- » Ensure the emergency stop button is “released”;

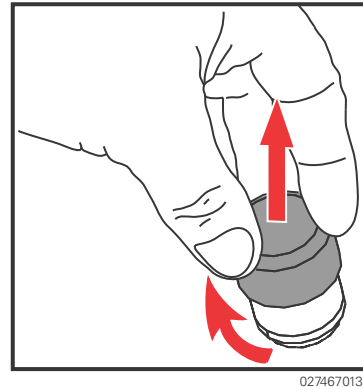

- » Release speed pedal completely;

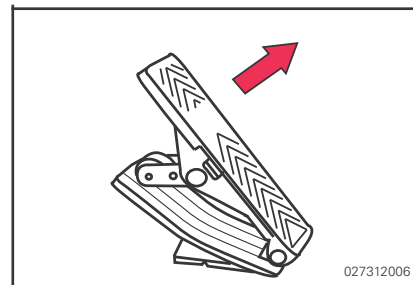

FORWARD MOTION

⚠ WARNING

Accident hazard

The operator should be thoroughly familiarized with the steering and handling of the vehicle before operating. Abrupt changes in direction will occur when the steering wheel is moved quickly and could cause loss of control. Lack of training may result in severe injury or death.

⚠ WARNING

Crush hazard

The operator must wear the seat belt at all times. Failure to do so may result in severe injury or death.

⚠ WARNING

Accident hazard

The operator must be aware of the vehicle configuration and normal/inverted drive setting at all times. In the inverted configuration, the transmission lever and the steering wheel are inverted.

Not taking into account the vehicle configuration may result in severe injury or death.

- » Check the display to see if the vehicle is in the normal configuration or in the inverted configuration;

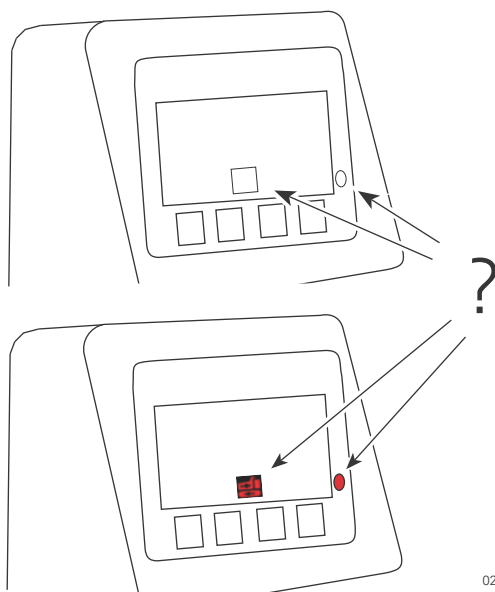
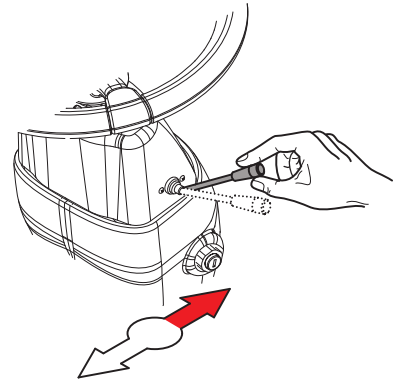

Figure 166
Normal configuration (top), inverted configuration (bottom)

- » Push the transmission forward;



0274960084

- » Slowly apply pressure on the speed pedal;

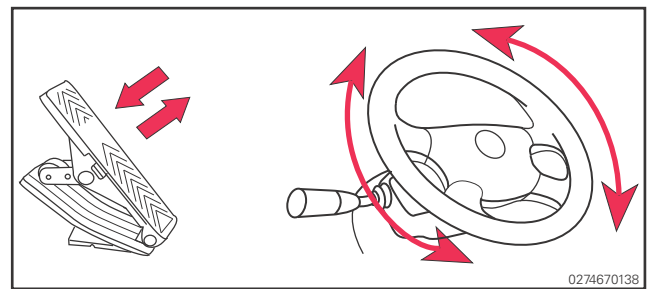

0274670138

- » To turn right, turn the steering wheel to the right;
- » To turn left, turn the steering wheel to the left;
- » To brake or slow down, gradually release pressure on the speed pedal;
- » In case of emergency, press the emergency stop button.

DRIVING INSTRUCTIONS

REVERSE MOTION

⚠ WARNING

Accident hazard

The operator must be aware of the vehicle configuration and normal/inverted drive setting at all times. In the inverted configuration, the transmission lever and the steering wheel are inverted.

Not taking into account the vehicle configuration may result in severe injury or death.

- » Check the display to see if the vehicle is in the normal configuration or in the inverted configuration;

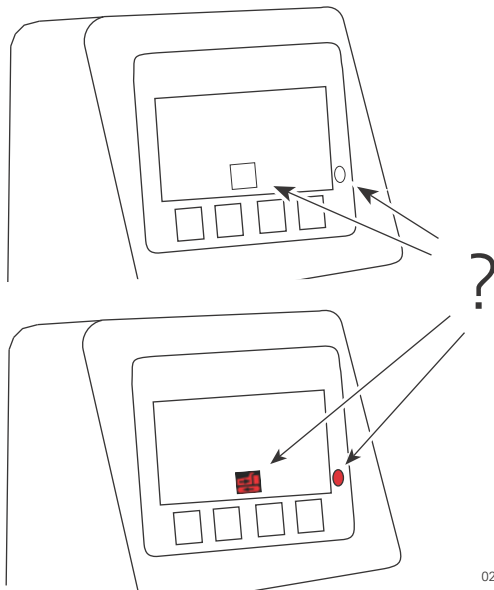
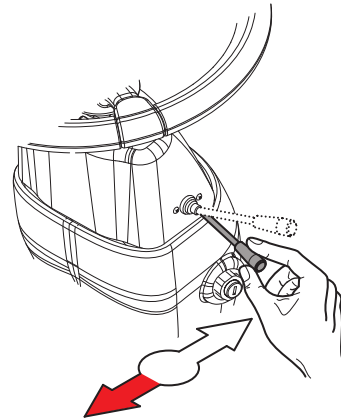

Figure 167
Normal configuration (top), inverted configuration (bottom)

0275640043

To go into reverse, stop the vehicle, then, pull back on the transmission lever.



0274960085

- » Slowly press the speed pedal

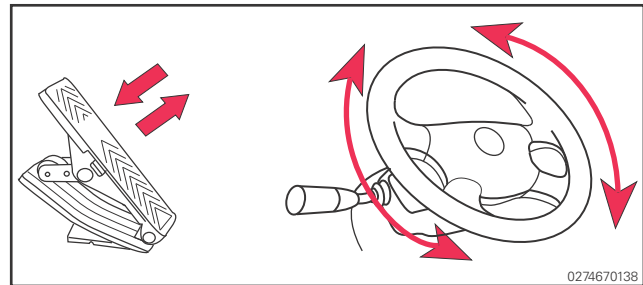

0274670138

- » To turn, turn the steering wheel in the desired direction;
- » To brake or slow down, gradually release pressure on the speed pedal or bring the transmission lever to neutral;
- » In case of emergency, press the emergency stop button.

Ensure the backup alarm operates while the vehicle moves in the direction of its own dump body. Observe all warnings and safety precautions listed in the Forward Motion section.

SWINGING

To swing the upper frame of the vehicle, use the joystick alone or the joystick with the alignment switch. Proceed as follows:

- » If not already done, press the joystick ON/OFF switch to ON;

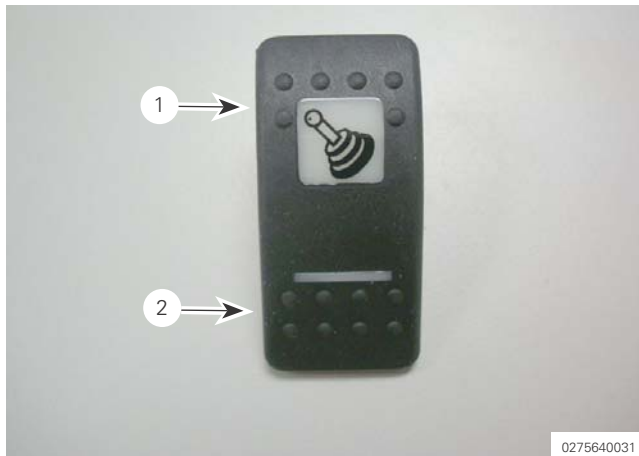

Figure 168
1. Joystick ON
2. Joystick OFF

- » To swing, tilt the joystick in the desired direction;



Figure 169
Joystick with swing function

- » In case of emergency, press the emergency stop button to stop the swinging motion.

Ensure the alarm sounds while the vehicle swings. Observe all warnings and safety precautions.

⚠ DANGER

Crush hazard

The upper section of the vehicle will extend beyond the track width when swinging. While doing so, it could hit someone and cause severe injuries or death. Always check that the surrounding area is clear before swinging the vehicle.

⚠ WARNING

Accident hazard

Swinging the vehicle while it is in motion could cause a flip over if the vehicle exceeds its slope limit. Always use caution when driving on a slope.

- » Perform a visual verification that it is safe and clear for the vehicle to swing.

NOTE : Use the mirrors and cameras to assist in checking the area around the vehicle.

Upper Frame Rotating Radius

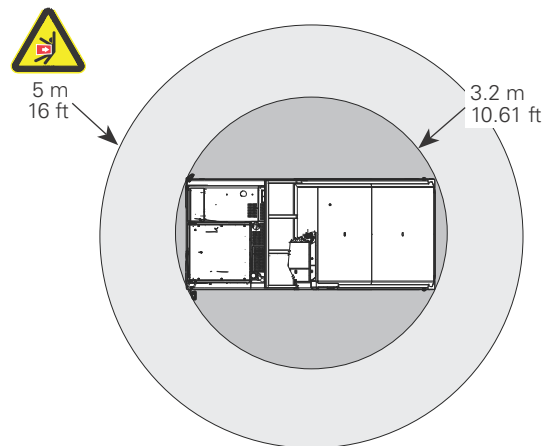

Figure 170
Vehicle view from top to show the required space for rotation and safety perimeter (not to scale)

The upper frame of the Panther T14R has a rotating radius of 3236 mm (10.61 ft). When rotating the upper frame, take all required precautions and ensure there is enough space around the vehicle. Check for presence of personnel before rotating the vehicle.

If rotating the upper frame for maintenance in a repair shop or hangar, establish a safety perimeter of at least 5 m (16 ft) around the vehicle.

DRIVING INSTRUCTIONS

STEERING WHEEL HANDLING

DANGER

Accident hazard

The operator must be aware of the vehicle configuration and normal/inverted drive setting at all times. In the inverted configuration, the transmission lever and the steering wheel are inverted.

Not taking into account the vehicle configuration may result in severe injury or death.

For smooth operation, do not turn the steering wheel suddenly or hit the stop with force at the end of the turn. Sharp turns of the steering wheel will produce jerking motion and possibly over-correction on the next move of the steering wheel.

Adjust the amplitude of the steering movement with the speed of the vehicle. The faster the speed of the vehicle, the slower the steering inputs should be, except for an emergency situation.

At slow speed, turning the wheel slightly will decrease track speed on one side and increase it on the other side. Turning the wheel further will stop one track and keep the other one running. Turning the wheel to the stop will produce counter-rotation: turning one track in one direction while turning the other track in the opposite direction.

At full speed, both tracks may already be at maximum speed so the vehicle is likely to slow down slightly when turning.

AUTO-BRAKE

If the vehicle is immobilized for a few seconds, the auto-brake function is activated and brakes are applied automatically. This is to prevent the vehicle from creeping backwards on a slope. As soon as the speed pedal is pressed again, the auto-brake function is deactivated and brakes are released.



The icon shown above appears on the LCD display whenever the auto-brake function is activated.

OIL TEMPERATURE AND DRIVE SYSTEM

Low oil temperature

Low hydraulic oil temperature will trigger a warm up sequence of the drive system.



The icons shown above appear on the LCD display whenever the oil temperature reaches critical low level.

When the oil temperature is colder than +5 °C (+41 °F), there is a warm up curve of the drive system that limits the diesel engine maximum speed to 1400 rpm. The snowflake icon appears on the display in that oil temperature range.

When a low oil temperature indication occurs, leave the engine running at idle speed until the oil returns to normal operating temperature or work while applying only a light load to the engine.

When the oil temperature increases above +5 °C (+41 °F), the buzzer will sound and the snow icon will flash. *The accelerator pedal must be released before the vehicle can regain its full speed capacity (2100 rpm max.).*

High oil temperature



High hydraulic oil temperature could cause permanent damage to the hydraulic circuit and to several components. To prevent this, heat sensors and the vehicle microprocessor will trigger a cooling sequence to lower the oil temperature.

High hydraulic oil temperature can cause oil degradation and, eventually, bring premature failure of the components operating with that fluid.

As the oil temperature increases, its viscosity decreases. Therefore, a hydraulic system is operating too hot when it reaches the temperature at which oil viscosity falls below that required for adequate lubrication.

Hot oil can destroy hydraulic components, seals, hoses and the oil itself when high-temperature operation is allowed. Avoid this situations as much as possible.

Oil in the tank

Maximum diesel engine speed, 2100 rpm, is allowed with hydraulic oil temperature up to +76 °C (+169 °F). At higher hyd. oil temperature, allowed maximum engine speed will be gradually reduced (down to 1700 rpm) as the oil temperature increases.

If the oil temperature rises at +85 °C (+185 °F) or more, the drive system will be limited to 50 % of maximum speed (and the engine speed limited to 1700 rpm) until the hyd. oil temperature goes down to a safe level.

NOTE : Operator must stop the vehicle to prevent damage if alarm sounds. Inspect cooling components at once. When the high oil temp icon and the yellow triangle flashes, release the accelerator pedal completely to enable the vehicle to regain full speed capability.



This icon appears on the LCD display whenever the oil temperature reaches a critical levels.

Oil in the planetary gearboxes

High oil temperature in the planetary gearboxes will result in a drive system power adjustment on two levels:

» First level:



» Second level:



The icons shown above appear on the LCD display whenever the oil temperature reaches a critical level in the planetary gearboxes.

- » Yellow temperature icon: max speed reduced by 25%.
- » Red temperature icon: max speed reduced by 50%.

NOTE :

Operator must stop the vehicle to prevent damage if alarm sounds. Inspect :

- » **Hyd oil level and quality in the planetaries;**
- » **Planetaries housing and components.**

Lowering the oil temperature in the tank or in the planetary gearboxes

When a high oil temperature indication occurs, the power adjustment will slow down the vehicle to lower the oil temperature.

Regaining speed capability after a first level alarm (flashing yellow planetary icon)

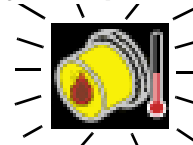

Once the oil temperature drops below the critical level (the yellow planetary icon will flash), release the accelerator pedal completely to enable the vehicle to regain full speed capability.

Regaining speed capability after a second level alarm (flashing red planetary icon)

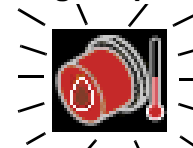

Once the oil temperature drops below the critical level (the red planetary icon will flash), release the accelerator pedal completely to enable the vehicle to regain full speed capability.

Regaining speed capability after a hyd oil temp alarm (red oil icon)



It is recommended to stop the vehicle and perform a quick check to try to spot the problem. Ensure the oil cooler is clean and air circulation is unobstructed. Maximum speed capability returns automatically when the oil temperature drops below the critical level (check the oil temperature gauge).

NOTE : Perform the clearing fault procedure to erase the fault.

DRIVING INSTRUCTIONS

Temperature sensor failure

The failure of a temperature sensor (in the tank or in the planetary) could lead to undetected high oil temperature.

Faulty temperature sensor in the tank

If this happens, there will be :

- » A high temperature icon (tank) and the minor fault icon (yellow triangle);



- » An entry in the Fault Log.

No.	Description	Qty	Hour
1	Hydros. oil temperature sensor	0	0

Faulty temperature sensor in the planetary

If this happens, there will be :

- » A high temperature icon (planetary) and the minor fault icon (yellow triangle);



- » An entry in the Fault Log.

No.	Description	Qty	Hour
17-1	Faulty right planetary temp. sensor	0	0

In both cases, replace the faulty sensor.

NOTE : Only one planetary is equipped with a temperature sensor.

The buzzer will sound when the minor fault icon appears.

OIL TEMPERATURE AND SWING SYSTEM

Low hydraulic oil temperature will result in a disabled swing system.



The snowflake and rotation padlock icons appear when the oil temperature is below -20 °C (-4 °F)

When a low oil temperature indication occurs, the swing system is temporarily disabled. Drive the vehicle without swinging the upper frame or wait until the oil temperature raises above -20 °C (-4 °F).

The padlock icon will start to flash and the buzzer will sound for 5 seconds to signal the operator that the oil temperature has raised above the critical temperature and thus the rotation system becomes operational.

The dump body system is not affected by the hydraulic oil temperature. 0

SLOWING DOWN AND BRAKING

⚠ WARNING

Impact hazard

Do not use the emergency stop button as a standard brake while the vehicle is in motion. The operator could lose control of the vehicle and cause an accident.

⚠ WARNING

Impact hazard

The vehicle loses its braking ability when:

- » **the planetary gearboxes are disengaged,**
- » **the vehicle is untracked,**
- » **the tracks are loose.**

Braking problems could cause accident and injuries to the operator, passengers or bystanders. Ensure the track tension is correct at all times.

To brake while the vehicle is in motion, gradually release pressure on the speed pedal. The drive system will act as a brake and cause the vehicle to progressively slow down and come to a complete stop. Never use the emergency stop button as a standard brake while the vehicle is in motion.

Never brake suddenly, especially when going down hill. Harsh operation at high speed will cause unnecessary jars to the vehicle and could cause loss of control.

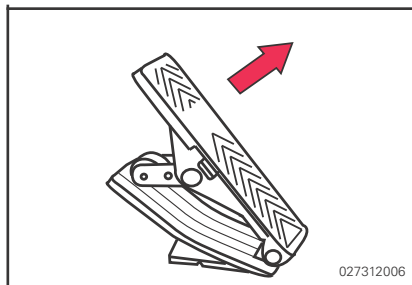

Ensure the track tension is correct otherwise the brake operation will be impaired.

PARKING BRAKE

The vehicle is equipped with a parking/emergency brake. Apply the parking brake only once the vehicle is completely immobilized.



The icon shown above appears on the LCD display whenever the parking brake is applied.

Take all necessary precautions when parking the vehicle. Select a safe and level location, set the parking brake. Shut off the engine and remove the keys from the ignition switch.

PARKING THE VEHICLE

⚠ WARNING

Accident hazard

Never leave the vehicle without setting the parking brake and always shut off the engine. Do not park the vehicle on a slope where it could start to roll or slide. Always check the parking brake system for proper function before operating the vehicle. Failure to do so could cause injury or death.

When parking the vehicle, select a safe and level location. Avoid sloped terrain. If parking the vehicle outside for extended periods of time, consider water or snow accumulation on the vehicle.

Protect the tracks from direct sunlight if parking outside for long periods of time. Sunlight can cause damage to the rubber of the tracks.

DRIVING INSTRUCTIONS

DRIVING A PARTIALLY DISABLED VEHICLE

In the event of a component failure, the operator will be informed of the situation by the LCD display. According to the severity of the failure, three possibilities exist:

- » Driving with the “Limp Home” Mode;
- » Driving with the Emergency Drive Module;
- » Towing the vehicle.

⚠ WARNING

Accident hazard

Operating the vehicle as a dumper or carrier with the emergency drive module is unsafe. Do not work with a partially disabled vehicle. Return to the repair station by the shortest path possible.

A partially disabled vehicle should stop any work in progress and be brought to a repair station at once.

Driving with the “Limp Home” Mode



The icon shown above appears on the LCD display whenever the limp-home function is activated by the micro-controller.

In the event of a minor failure, the microcontroller can still control the drive system:

- » High temperature of hydrostatic oil in the tank;
- » High temperature of the hydrostatic oil in the planetary gearboxes;
- » Interruption of communication with the ECM (Electronic Control Module) of the engine.

For the failures listed above, the vehicle maximum speed will be cut by 25% or 50% and the anti-stall feature will be cancelled. The “Limp Home” mode is indicated with the yellow turtle icon on the main screen of the display.

Driving with the Emergency Drive Module

⚠ WARNING

Accident hazard

The operator must be aware of the vehicle configuration when using the emergency drive module. In the inverted configuration, the sliders operation will be inverted.

Not taking into account the vehicle configuration may result in severe injury or death.

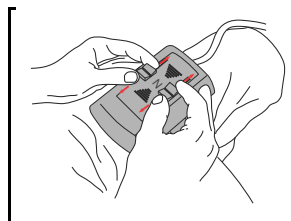

The microcontroller cannot control the drive system, in the event of a failure such as:

- » Microcontroller failure;
- » Transmission selector failure;
- » Speed pedal potentiometer failure;
- » Steering wheel potentiometer failure.

If one of these situations occurs, use the emergency drive module to drive to the nearest repair facility. Refer to “Using the Emergency Drive Module” for complete instruction on how to use the module.

NOTE : With the use of the emergency drive module the anti-stall feature is cancelled and maximum speed is reduced.

Completely Disabled Vehicle

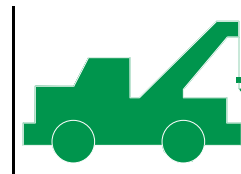

In case of a major failure, tow the vehicle to the nearest repair facility. Refer to “Towing” for complete instructions.

ADVANCED GUIDELINES FOR DRIVING

LOSS OF CONTROL OF THE VEHICLE

WARNING

Accident hazard

Abrupt changes of vehicle's motion, such as but not limited to, applying the parking brake while in motion, rapid movement of the steering wheel, etc., should be avoided as they lead to vehicle imbalance which could ultimately result in loss of control, tip-over and/or roll-over of the vehicle

Skidding on a slope can lead to loss of control. To regain control of vehicle, adjust speed of each track until control is regained. To brake when skidding, regain control of vehicle; then slow down gradually.

OFF-HIGHWAY OPERATION

The off-highway operation carries potential risks. Any terrain, which has not been specially prepared to carry vehicles, presents a danger where surface, dirt substance and exact steepness are unpredictable.

An operator who takes a vehicle off-road should always exercise the utmost care in selecting the safest path and keeping close watch on the terrain ahead. The vehicle should not be operated by anyone who is not completely familiar with the driving instructions applicable of the vehicle, nor should it be operated in steep or treacherous terrain by anyone who has not become thoroughly familiar with the vehicle performance.

Never assume that one off-road all-terrain vehicle has the same capabilities as another. There are a wide variety of different sizes and designs of off-road all-terrain vehicles. Each is built with differing abilities.

One must remember that, with a tracked vehicle, the traction is so great that it can propel itself beyond its own limits of stability. This can occur on all types of terrain.

Moreover the vehicle can continue to move, even when much of its traction is no longer supported by the ground. As a result, the vehicle can be driven over a drop-off without any prior warning that tip-over is about to occur.

The vehicle is capable of sharp turns as well as zero turn radius. However, performing these manoeuvres frequently may cause premature wear on undercarriage components, including the tracks. Wide radius turns will minimize wear.

GENERAL SAFETY PRECAUTIONS

Care, caution, experience and driving skill are the best precautions against the hazard of off-road all-terrain vehicle operation.

Whenever there is the slightest doubt that the vehicle can safely negotiate an obstacle of a particular piece of terrain, always choose an alternate route.

In off-road operation, power and traction, not speed, are important. Never drive faster than visibility and operator ability to select a safe route permits.

Constantly watch the terrain ahead for sudden changes in slopes or obstacles, such as rocks or stumps, that may cause loss of stability, resulting in tip-over or roll-over.

Never jump out of the vehicle while it is still moving. When driving the vehicle with the cab door "latched-opened", always stop the vehicle completely before getting out. The same applies to the passenger, if applicable.

GUIDELINES FOR VEHICLE GRADEABILITY LIMIT

WARNING

Tip over hazard

The specifications for the vehicle may state maximum performance limit guidelines for uphill, downhill, and sidehill operations.

These limit guidelines are determined with the vehicle being stationary on a firm, flat surface. The extent to which the vehicle can operate safely on such slopes will depend on the expertise of the operator and his familiarity with the vehicle. The loading of the vehicle will also affect the vehicle performance on slopes. Moreover, under actual operating conditions, the slope of the terrain is constantly changing and sudden local variation may result in slopes which exceed operational limit guidelines, although the overall slope of the terrain is within safe operational limits.

Adapt operation of the vehicle to actual terrain conditions. Failure to do so could lead to loss of control and potentially severe injuries or death.

The ability of the vehicle to travel on slopes is stated on the following sub-sections. These specifications apply to a new vehicle as delivered from the factory. Any addition of equipment or modification may change these limits.

ADVANCED GUIDELINES FOR DRIVING

Transmission Lever Handling

Always stop the vehicle before switching the transmission lever from Forward to Reverse and vice versa. If the direction of travel is reverse suddenly, the hydrostatic drive system may sustain damage.

Move the transmission lever smoothly and slowly. Do not perform unnecessary counter-rotation turns or sudden turns at high speed. Such frequent manoeuvres could cause damage, premature wear or increase risk of hitting objects/obstacles.

Tilt Sensor Alarm Sounding

If the tilt sensor audible warning sounds, the operator should take action immediately to avoid a possibly dangerous situation.

Specific action vary according to the situation at hand, however prudent driving dictates the following:

- » release some pressure on the speed pedal;
- » drive carefully using the appropriate path and as described in the following Uphill/downhill and Side-hill Driving sections;

UPHILL DRIVING

Due to configuration, off-road all-terrain vehicles have excellent climbing ability, so much so that tip-over is possible before traction is lost. For example, its common to encounter terrain situations where the top of the hill has eroded to a point that the hill peak rises very sharply. The tracked vehicle can readily negotiate such a condition, however, in doing so, when the front of the vehicle is driven to a point that the vehicle's balance changes rearward roll over can occur.

The same situation may apply if an embedded object causes the front of the vehicle to climb more than desired. If such a situation occurs take an alternate route. Be aware of side hill driving dangers when doing so.

It is also wise to know the terrain condition on the other side of the hill or bank. All too often there exists a sharp drop-off that is impossible to negotiate or descend.

The vehicle is equipped with a dump body, always evaluate load stability before riding steep uphill slopes.

Maximum uphill operation :

- » With empty dump body : 31 degrees
- » With loaded dump body : 15 degrees

DOWNHILL DRIVING

As a rule, off-road all-terrain vehicles can climb slopes that are steeper than they can safely descend. Therefore, it is essential to assure that a safe route exists to descend a slope before you climb it.

Decelerating while negotiating a slippery downhill slope could bring the vehicle into a slide. Maintain steady speed and/or accelerate slightly to regain control.

Maximum downhill operation :

- » With empty dump body : 31 degrees
- » With loaded dump body : 15 degrees

SIDE HILL DRIVING

Whenever possible, such operation should be avoided. If necessary, do so with extreme caution. Driving sidehill on steep inclines could result in roll-over. In addition, slippery or soft surfaces could result in uncontrollable side sliding. A side-slide may be overcome by attempting to turn the vehicle uphill and accelerating forward out of the slide. Do not attempt to turn the vehicle downhill with the slide. Avoid all objects or depressions that will intensify the raising of one side of the vehicle higher than the other, thus causing roll-over.

Maximum sidehill operation :

- » With empty dump body : 21,8 degrees
- » With loaded dump body : 15 degrees

DROP-OFFS

The operation of tracked vehicle differs greatly from that of a four wheeled vehicle. For example, a four wheeled vehicle will “bottom-out“ and usually stop if either the front or rear wheels are driven over a drop-off.

WARNING

Accident hazard
Avoid negotiating drop-offs. Reverse and select an alternate route. Failure to do so may lead to accident and cause injury or death.

A tracked vehicle, however will continue to proceed over the drop-off until its center of gravity passes the edge of the drop-off and the vehicle plunges forward. If the drop is sharp or deep, the vehicle will nose dive and tip-over.

TRACK TENSION

The track tensioners are equipped with a safety relief valve in addition to the manual override valve. If an extreme tension is applied to a track, the relief valve will open and release tension to prevent track damage. Tension is restored automatically.

Weak track tension (when track tensioning cylinders are engaged) could occur when air is trapped in the cylinders. Bleed air from the cylinder to correct the situation.

DETRACKING

WARNING

Collision hazard
Detracking can lead to loss of control or skidding. Maintain tracks in top condition, check track tension and drive carefully. Failure to do so may lead to accident and cause injury or death.

Loose tracks, combined with other factors could lead to detracking. This could provoke an accident, especially on sloped terrain. Avoid these situations as much as possible.

ROTATION BRAKE

WARNING

Accident hazard
In a slope with the vehicle fully loaded, the brake may fail to prevent unwanted rotation of the upper frame.
Always travel on a perpendicular path

The upper structure of the vehicle will stop to swing when the joystick is released by the operator. The swing brake will be applied automatically when there is no command to activate the swing system.

ADVANCED GUIDELINES FOR DRIVING

ICE HAZARD

Snow and ice can be slippery for rubber tracks. Be careful on these surfaces and avoid lateral slopes as much as possible.

⚠ WARNING

Drowning hazard

The vehicle is very heavy. It could break the ice on a frozen body of water and sink. Never drive on frozen bodies of water.

Keep a safe distance with frozen bodies of water.

⚠ WARNING

Accident hazard

Rubber tracks may provide low grip on a smooth slippery surface such as an icy patch, a metal sloped ramp, etc. Drive with care on such surfaces.

Driving on these surfaces must be undertaken with great precautions as well as riding the vehicle sidehill. If the manoeuvre cannot be avoided, consider the following before proceeding:

- » Angle of the ramp/slope;
- » Path of vehicle on a sloped surface;
- » Dryness/wetness and temperature of the metal surface (for example, icy surface);
- » Load on the vehicle, C.G. position;
- » Experience of the driver;

RIDING ON ROUGH OR HAZARDOUS GROUNDS

Extremely rough rocky grounds, places with tree stumps, steel rods, metal scrap, sharp objects or rough concrete can damage the rubber tracks.

River beds or job site with rocks of different sizes can lead to rocks getting caught in the undercarriage/track and cause damage.

Do not ride on oil, fuel or chemical solvent which could react with the rubber of the tracks.

Do not drive on surfaces at high temperature such as asphalt or steel plates that have been a long time in the sun or where there have been fires or where ground fire remains.

Avoid turning in places where there is a large ridge. Approach such obstacles at a right angle.

If transporting loads (in the dump body for example) of chemicals, be sure to thoroughly rinse the tracks to avoid damage to the rubber tracks.

CROSSING IN SHALLOW WATER

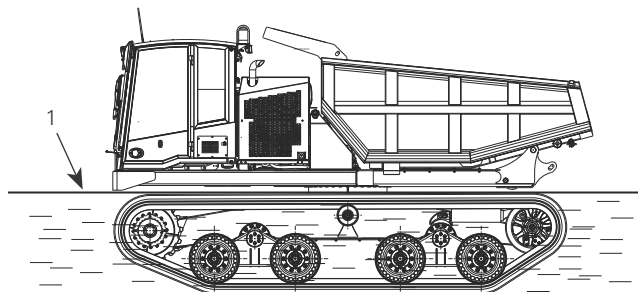

0275640053

Figure 171

1. Maximum water level allowed (no waves)

When crossing shallow bodies of water, the vehicle may proceed in water up to a height of 1200 mm (47 in). Allowed depth is less if there are waves on the water surface or if the vehicle is not level with the surface.

NOTE : Keep vehicle speed under 5 km/h (3 mph) to prevent creation of a wave.

⚠ WARNING

Drowning hazard

Driving in water means driving without knowledge of the type of surface under the tracks. Never ride in areas where the driver and passenger can be at risk.

An operator should always exercise the utmost care in selecting the safest and shallowest path if crossing water. Never proceed ahead if the bottom is not visible or if the bottom is soft and the vehicle could sink in. Select an alternate path if possible.

While the vehicle crosses the water, drive slowly, remain vigilant and stop at the first sign of trouble or if the water level rises above the wheels. The vehicle is not designed for long distance driving in shallow water. When the vehicle is parked at the end of the day, perform a short inspection to ensure no remaining water could cause damage.

If crossing shallow bodies of salt water or if operating near salt water, thoroughly clean the vehicle to prevent corrosion.

CENTER OF GRAVITY OF EMPTY VEHICLE

Refer to the next figure to locate the center of gravity of the vehicle when empty (all fluids at full but without options, without driver and without passenger).

Distance between front of vehicle and CG is 2704 mm (106.5 in), distance between ground and CG is 1092 mm (43.0 in).

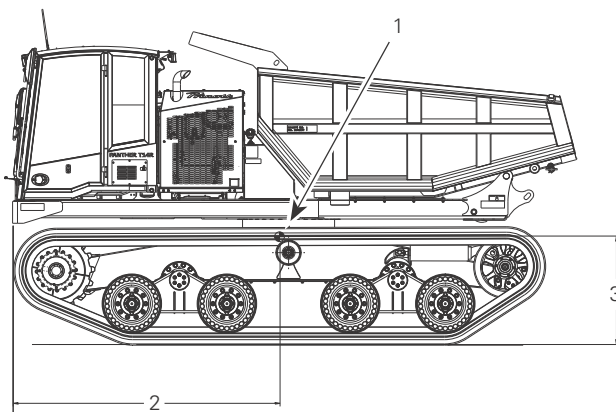

Figure 172

1. Center of gravity
2. Distance between front of vehicle and CG
3. Distance between ground and CG

FRONT COUNTERWEIGHT

The front counterweight, if installed, improves the stability of the vehicle while unloading the dump body.



Figure 173

1. Front counterweight bolted to the upper frame

ADVANCED GUIDELINES FOR DRIVING

LOADING AND UNLOADING VEHICLE ON RAMPS

When driving on ramps to load or unload the vehicle from a transport trailer, check the following to reduce the risk of accident:

- » The ramps are strong enough to support the weight of the vehicle (and its load if applicable);
- » Each ramp is wider than the tracks that will ride on it;
- » The angle of the ramps is moderate (less than 15°);

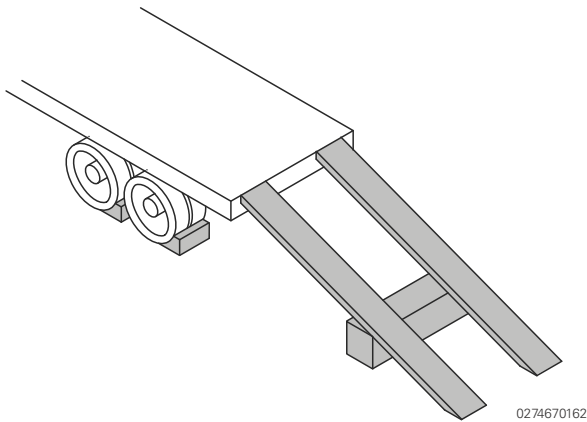

Figure 174
Moderate angle of the loading/unloading ramps

- » The ramps are not too long;
- » The ramps are well hooked to the transport trailer;
- » The ramps have a non-slip surface;
- » The ramps are clean and free of grease, oil, ice or loose material.

When driving on ramps to load or unload the vehicle from a transport trailer, observe the following precautions:

- » Perform the loading and unloading on firm ground only;
- » Stop the engine or the haulage truck, apply the brake and block the tires;
- » Arrange the ramps so they are parallel and in line;
- » Attach the ramps securely to the trailer;
- » Position the Panther vehicle in line with the ramps and approach at low speed;
- » Do not change direction once on the ramps. If required, drive off the ramps, re-align and drive again on the ramps;
- » After loading, put blocks at the front and the rear of the tracks of the Panther vehicle. Tie down in an "X" pattern using the "D" rings on the vehicle and strong chains.

OVERSPEED ON DOWNHILL SLOPES

Overspeed situations usually occur when the vehicle is loaded and travels at or near full speed on a flat terrain and then enters a downhill slope.

In overspeed, the hydrostatic motors will suddenly fail and thus withdraw the braking capacity of the vehicle. This situation is to be avoided at all costs.

NOTICE

Overspeed can cause permanent damage to the drive system. Remain vigilant and avoid path that could lead to this situation.

To prevent this dangerous situation, the operator must:

- » travel at moderate speed when the vehicle is heavily loaded and the path it follows has portions with downhill slopes;
- » slow down before driving on down slopes;
- » take an alternate path.

ANTI-STALL

The anti-stall feature is activated automatically if there is a difference between the required engine rpm (position of the throttle pedal) and the rpm the engine produces. The anti-stall feature decreases the hydraulic drive command to prevent an engine stall.

When the required and actual engine rpm return to the same level, the anti-stall is deactivated.

SPECIAL SITUATIONS

- » Towing the vehicle requires special precautions. Refer to “Towing” in the Drive System Maintenance Section for detailed information.
- » Certain chemical compounds could react with the rubber of the tracks or be corrosive and attack exposed surfaces of the vehicle. In these conditions, it is recommended to wash the vehicle thoroughly at the end of the work shift.
- » It is wise to wash the dump body clean at the end of the day. Certain material may harden or stick to the dump body surfaces and increase the risk of sticking loads.
- » If the vehicle becomes stuck, the track can be damaged by excessive material packing in the track/undercarriage. This is likely to occur when the track is spinning and begins to dig below the surface level. To minimize possible damage, it is recommended to tow the vehicle instead of trying to move it on its own. Attempting to clear excess material by driving is likely to cause some wear or damage.
- » Spinning the tracks or making frequent zero radius turns may cause premature wear. Constant operation on a hill or slope could also accelerate wear. This could be especially hard on track guides.
- » Working along a transition where one track is not fully supported by the ground could cause damage. If the side of the track comes in contact with curb lines or hard surfaces, it could damage the track or bend it severely on a permanent basis.
- » It is a good practice to return the vehicle to its normal configuration before shutting down the engine. This way, the next driver will have the controls with the “normal” functions.

DUMP BODY OPERATION

DUMP BODY OPERATION

This section applies exclusively to a vehicle equipped with a PRINOTH dump body:

OVERVIEW

Operating the dump body consist of loading material, transporting it and unloading it at a selected location. Safety precautions are very important in this type of operations.

The time required to raising the dump body completely will vary according to the load and to the engine rpm. When equipped with a dump body, the vehicle center of gravity (C.G.) moves as it is loaded and then raised to unload. This has little effect on stability as long as the vehicle is on a flat and firm ground.

A Panther T14R vehicle equipped with a dump body must only be operated as such and only by a qualified and trained operator.

Blind Spots

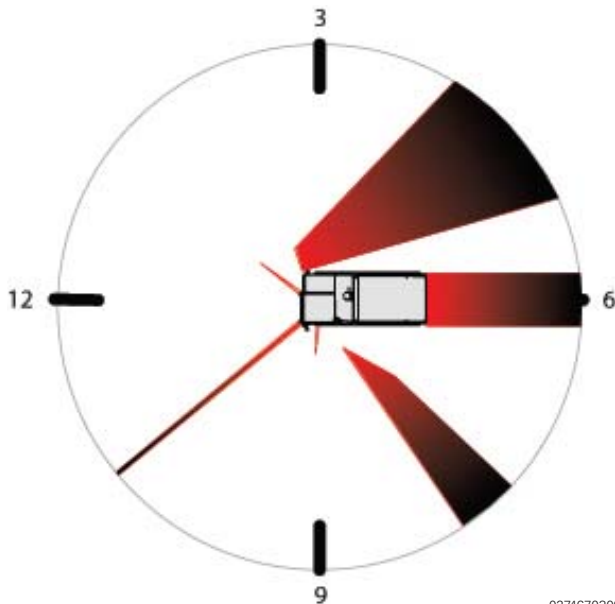

Figure 175
Vehicle view from top in the center of the circle with red/black blind spots

On the previous figure, 12 indicates front of vehicle (aerial view in normal configuration), 6 is rear, while 3 and 9 are the sides. The shaded dark areas are the blind spots of the vehicle.

The operator must be aware of the blind spots that exist with the specific configuration of the cab and equipment installed on the vehicle. The operator is responsible to maintain a good job site organisation to insure a safe operation of the vehicle.

Dump Body Specifications

The PRINOTH dump body has the following characteristics:

- » Maximum loading capacity :
 - » 13200 Kg (29100 lb) for the dump body.
- » Capacities for **the** dump body :
 - » 6,5 cubic meter heaped (8,5 cubic yard)
- » Maximum dumping angle of the dump body:
 - » 60 degrees.

Upper Frame Rotating Radius

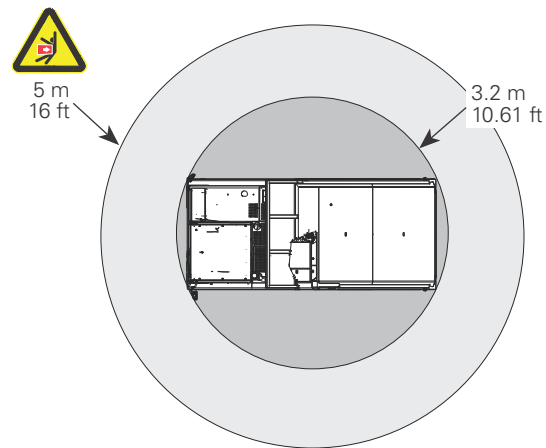

Figure 176
Vehicle view from top to show the required space for rotation and safety radius (not to scale)

The upper frame of the Panther T14R has a rotating radius of 3236 mm (10.61 ft). When rotating the upper frame, take all required precautions and ensure there is enough space around the vehicle. If rotating the upper frame for maintenance in a repair shop or hangar, establish a safety perimeter of at least 5 m (16 ft) around the vehicle.

Dump body position sensor

If installed, a sensor detects if the dump body is raised and reduces the speed of the vehicle as long as the dump body is not lowered. The buzzer sounds and the turtle icon appears in the display when the vehicle moves with the dump body raised.

Lowering the dump body with the engine off

The dump body control lever is not operational when the diesel engine is off. Turn on the diesel engine to lower the dump body.

Inspect and Prepare the Work Area

WARNING

Electrical hazard

Contacting electric lines with the dump body can cause electric shock or burn. Keep away from electric lines or power sources.

The operator should be familiar with the work area where the vehicle will operate. If dumping will be done at the edge of a particular site or location, make that point as stable and level as possible. Since the load distribution at the time of dumping puts the weight primarily on the rear section of the vehicle, try to increase stability at that point of dumping by building a raised pile of material at the very edge. This is to avoid a downward slope. If possible, avoid dumping right at the edge and dump short of that point, utilizing a bulldozer to push the material over the edge. Ensure the position of the raised body, when dumping, does not put it at risk of coming in contact with power lines. Check lighting if the work is to be performed at night or in the dark.

Dumping at an Angle from the Tracks

Because of the geometry of the vehicle, dumping at certain angles will result in pouring material on the tracks. To avoid this situation, perform dumping at right angles with the tracks or once aligned in the normal or inverted configuration.

Aerial High-Voltage Cables

WARNING

Electrical hazard

Contacting electric lines with the dump body can cause electric shock or burn. Keep away from electric lines or power sources.

Do not travel or operate the vehicle near electric cables. There is a hazard of electric shock which could cause severe injuries or death. If the vehicle has to get in motion near electric cables, observe the following:

- » **Before starting to work, inform the local power company and ask for the necessary actions;**
- » Electrocutation can occur even without contacting a cable. Always maintain a safe distance between the vehicle, the dump body and the aerial power line. The higher the voltage, the greater the safe distance needs to be.

Voltage of cables	Safety distance
125 kV	more than 3 m (10 ft)
125 to 250 kV	more than 5 m (16 ft)
250 to 550 kV	more than 8 m (26 ft)
more than 550 kV	more than 12 m (40 ft)

NOTE : Use this table as a guideline only, always contact the local power company.

- » Use a signalman to give warning if the vehicle approaches too close to the electric cables;
- » When working near high voltage cables, do not let anyone around the vehicle;
- » If a part of the vehicle, or dump body, should come very close or directly in contact with the power lines, the operator should not leave the cab until it has been confirmed that the electricity has been shut off. Do not let anyone near the vehicle.

Ventilation and Toxic Dust

When working in enclosed areas, ensure adequate ventilation is available. Take every precautions to prevent gas poisoning.

Certain types of dust (Asbestos for example) may be harmful to health and could be present on the work field. Take appropriate steps to prevent breathing airborne dust:

- » Spray water to keep down the dust when cleaning. Do not use compressed air for cleaning;
- » Do not allow unauthorized personnel to approach the work site;
- » Operate the vehicle in a position where the wind pushes the dust away from the vehicle
- » Observe local rules and environmental standards.

Distribute Load Properly

Ensure the material is loaded onto the vehicle from the front near the cab/cowling to the back as evenly as possible. Do not load too heavily, especially if the material being dumped has the potential to floor poorly.

DUMP BODY OPERATION

Driving with a Load

Some PRINOTH dump body models are not equipped with a tail gate, in this case, driving a steep incline could result in a loss of bulk material. Anticipate the path of the vehicle to avoid unwanted material loss before designated dumping site.

A loaded dump body changes the position of the center of gravity of the vehicle. This, with the additional weight must be taken into consideration for safe driving.

Driving to Reduce Vibration

Terrain in the work site could be rough and cause vibrations to be transmitted to the cab and ultimately to the operator.

Whenever possible, follow these recommendations to reduce vibration and fatigue to the minimum:

- » select a path with less obstacles;
- » reduce speed;
- » when possible, stop vehicle and take some rest;
- » carefully adjust seating position and seat suspension;

Best Braking Performance

A loaded vehicle will require a longer braking distance. Anticipate vehicle reactions and follow a safe path that takes the load into consideration.

Best braking performance is highly related to the type of surface on the ground, the degree of slope, the load in the dump body and the track wear.

Avoid sliding ground and try to decelerate while driving in straight line uphill or downhill. Braking while driving sidehill is less effective.

Driving to and from the discharge zone

- » Always wear the seat belt.
- » Lower the dump body before starting to travel.
- » On rough terrain, travel slowly and avoid sudden change in direction.
- » Avoid paths that require to travel over obstacles, otherwise take precautions and drive carefully.
- » Do not overload the dump body.

Precautions While Dumping



1105340024

Figure 177

Never exceed the inclination limit when dumping the load

⚠ WARNING

Impact hazard

Material falling from a raised dump body could crush someone.

Observe all safety precautions when operating the dump body.

⚠ DANGER

Tip over hazard

Never exceed the vehicle limit when driving on slopes or while dumping the load.

Do not use the swing function or carry out dumping operation on slopes, regardless of the orientation of the tracks. The vehicle could lose its balance, tip over and cause severe injuries or death. It is especially risky to dump downhill. Only dump if the vehicle is on firm, level ground.

Ensure there are no bystanders or workers around the area where the material will be dumped.

Always apply the parking brake before starting to dump material.

Do not dump side-by-side with another vehicle; if one of the vehicles does tip over, it would most likely disrupt the next vehicle and cause an unanticipated accident. Most importantly, check to make sure that there are not any other workers near the dumping site who may be working on other jobs and may not be totally aware of the dumping process.

Remember that the center of gravity of the vehicle continuously changes while the dump body raises, the load dumps and the dump body lowers. This could greatly affect the stability of the vehicle if ground is unstable.



Figure 178

1. Tilt forward to lower the dump body
2. Tilt backward to raise the dump body

The joystick operates the dump body position cylinders. To raise the dump body, pull the joystick. To lower the dump body, push the joystick forward. The speed of up/down operation increases as the joystick is pushed further in the selected direction.

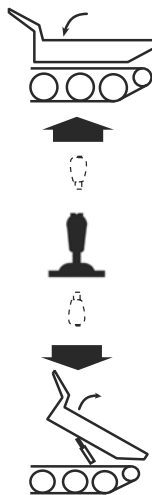

Figure 179

Dump body control

⚠ WARNING

Impact or electric shock hazard
Contacting electric lines with the dump body can cause electric shock or burn.
Material falling from a raised dump body could crush someone.
Observe all safety precautions when operating the dump body.

Have someone to give signals to the vehicle operator when aerial power cables are present on the work zone. Check with electricity company before starting of operation. Going close to high-voltage cables can cause electric arc, even if there is no direct contact between the cable and the dump body. The higher the voltage on the power lines, the greater the safety distance must be.

If the dump body touch an electrical cable, the operator should remain in the cab and call someone to report the situation and get help.

Preventive actions include shoes with rubber soles for the operator and use of someone to signal a path to avoid power lines.

Sticking Load

A sticking load is a kind of material that will partly or entirely stick to the dump body when it is raised to dump. Clay is a good example. A load that will freeze in the dump body is another. This situation presents disadvantages and raises the risk of accident because it increases the shift of the center of gravity thus potentially creating instability.

When possible, avoid leaving material that could freeze overnight in the dump body.

⚠ WARNING

Crush hazard
Never try to remove a sticking load manually on a partially or completely raised dump body. The load could loosen suddenly and crush someone. Always remove a sticking load while the dump body is completely down.

Keep the dump body surfaces as clean as possible. Avoid loading material that could stick to the dump body. If loading cannot be avoided, lower the dump body entirely with the cylinder control valve partially open (avoid lowering the dump box with the cylinder control valve completely open). Turn off the engine. Then unload the dump box manually or with the recourse to a mechanical aid (being careful not to damage the dump body).

DUMP BODY OPERATION

Do not use the cylinders to loosen (“shake”) loads stuck in the dump box.

Do not move the vehicle and apply the brakes while the cylinder is partially or fully extended to loosen loads stuck in the dump box.

Ground Stability

Ground stability is very important to ensure safety of dumping operation.

Raising the dump body moves the center of gravity of the vehicle higher and backward. Ensure the ground is strong enough to support the vehicle.

Dump Body Maintenance

NOTICE

If the dump body is loaded with material such as salt, ammonium sulphate, potassium chloride, potassium sulphate or phosphates, the dump body, frame and tracks should be washed thoroughly after each work shift.

- » Hydraulic hoses should be checked regularly and replaced if worn out or damaged.
- » Grease the dump body pivots every 50 hours or more often if required.
- » Check the lift cylinders for leaks once the dump body is raised and the safety rod is installed. Leak could indicate worn seals.
- » Keep the interior of the dump body clean and smooth to prevent sticking load.
- » Inspect safety rod periodically, replace if required.

SAFETY ROD



Figure 180

1. Safety rod in the stowed position

⚠ WARNING

Crush hazard

If the raised dump body is not secured with the safety rod, an accidental activation of the joystick or a cylinder failure could lower the dump body and cause severe injuries or death. Always secure the dump body with the safety rod before working under it.

Never work under the raised dump body unless the safety rod is installed and secure. A label should also be installed to lock-out/tag-out the joystick.

The safety rod is designed to support an empty dump body. Always empty the dump body before installing the safety rod.

Do not use the safety rod to support the dump body when replacing the dump cylinders, hydraulic hoses or other equipment. In such cases, always support the dump body with a crane or lifting equipment.

⚠ WARNING

Accident hazard

A raised dump body could contact aerial power lines, damage dump body/frame and generate instability. Always lower the dump body when driving the vehicle.

Never drive the vehicle with the safety rod installed. The rod is not design for dynamic forces and side loads.

Installing the Safety Rod

- » Set the vehicle on a firm and level ground.
- » Verify that the dump body is empty, if not empty it.
- » Survey the area around and above the vehicle, ensure there are no power lines above, other obstacles or personnel close by.
- » Apply the parking brake, leave the engine running.
- » Using the joystick in the cab, raise the dump body completely.
- » Stop diesel engine.
- » Remove the safety rod locking pin and pull out the safety rod from its stowed position.

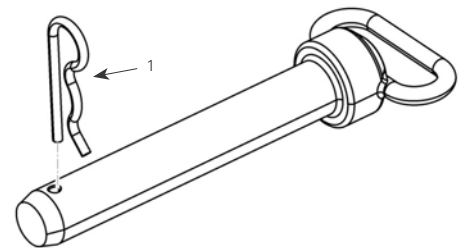

0275640098

Figure 181

1. Safety rod locking pin

- » Insert the safety rod in the dump body forward orifice aligned with the slotted cavity of the dump body. Secure with the locking pin.

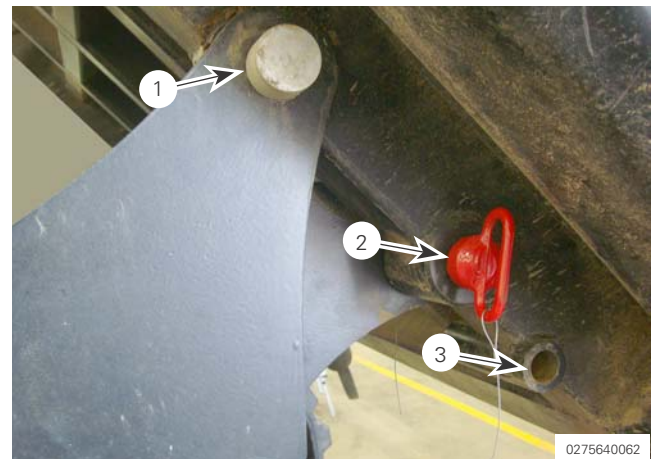

0275640062

Figure 182

1. Left pivot of the dump body
2. Safety rod (dump body locked in the raised position)
3. Stowing cavity of the safety rod

DUMP BODY OPERATION

NOTE : It is a good habit to check the lift cylinders for leaks once the dump body is raised and the safety rod is installed. Always install the safety rod before having body parts under the dump body.

Removing the Safety Rod

» Survey the area under the dump body, ensure there are no obstacles or tools left on the frame or personnel close by;

» Remove the locking pin on the receptacle of the dump body.

NOTE : If the safety rod cannot be removed because it is stuck in the slotted hole of the receptacle, start the engine and raise the dump body slightly to free the locking pin.

» Remove the safety rod and reinstall it in the stowed position. Install the locking pin.

» Using the joystick in the cab, lower the dump body completely;

DUMP BODY MODIFICATION AND USE

WARNING

Crush hazard

Do not attach an equipment, a device or another object in the dump body. Doing so will invalidate the ROPS certification. Carry only bulk material in the dump body.

The vehicle has been designed to transport loose material. Do not modify the dump body in any way.

SAFETY CHECK LIST

Operating the vehicle as a dumper carrier with known failures or with the emergency drive module is unsafe. Do not work with a partially disabled vehicle.

The operator is responsible to maintain a good job site organisation to insure a safe operation.

Daily Vehicle Check

- » Perform a complete walk-around of the vehicle;
- » Check track, wheel and sprocket condition;
- » Check windshield cleanliness;
- » Check mirror adjustment and cleanliness;
- » Check all lights of the vehicle;
- » Check operation of dump body, check cylinder tube and rod attaching points;
- » If equipped, check tailgate locking system;
- » Check underneath vehicle for oil leaks/spills;
- » Check back-up alarm;
- » Check brake operation;
- » Check condition of the dump body safety rod;
- » Check seat belt function.

Operator Protective Equipment

- » Wear reflective, high visibility vest;
- » Wear hard hat when working near equipment;
- » Wear protective footwear;
- » Check condition of first aid kit;
- » Ensure the orange triangular tag is attached to the rubber strip of the windshield;
- » Check fire extinguisher condition;
- » Inspect safety rod periodically, replace if required.
- » Provide cones for work area near traffic.

Backing Dump Vehicle

- » Keep rear view mirrors clean;
- » Never back faster than walking speed;
- » Driver and backer must agree on a STOP signal.
- » Get out of the cab and look if a backer is not available;

Good Practices

- » Move the joystick smoothly and slowly.
- » Never raise dump body on uneven or unstable ground;
- » Do not carry out dumping operation on slopes. The vehicle could lose its balance, tip over and cause severe injuries or death. It is especially risky to dump downhill. Only dump if the vehicle is on firm, level ground.
- » Check for overhead wires before raising dump body;

- » Clear workers from area before dumping;
- » Do not leave the vehicle during the dumping cycle. Remain at the controls;
- » Never let anyone go under a raised loaded dump body;
- » Never leave the dump body raised or partly raised while vehicle is unattended or while maintenance is performed;
- » Never allow anyone to ride, work or stand in the dump body while the engine runs unless performing maintenance and observing all applicable safety precautions;
- » Never drive the vehicle with the dump body safety rod installed;
- » Always evaluate load stability before riding steep uphill slopes (the dump body has no tail gate);
- » After dumping, do not move the vehicle until the dump body is lowered completely;
- » When loading the dump body, do not exceed capacity in volume and weight;
- » Observe all local and national regulations applicable to the work in progress;
- » If exiting the cab, survey area for traffic before exiting;
- » Never leave the dump body fully or partially raised while the vehicle is not under surveillance, waiting for maintenance or repair unless the safety rod or other robust lifting system is installed to secure it.

TECHNICAL DATA

TECHNICAL DATA

VEHICLE SPECIFICATIONS

Category		
Vehicle	Panther T14R	
Recommended use	Dumper	
Possible use	Hauling soil	
Working environment	Humid region, wood, field, construction site	
Season	Four seasons	
Type of working surface	Dry or wet mud, rock, snow	

Dimensions		
Overall length	5782 mm	227.6 in
Overall width (including mirrors)	2802 mm	110.3 in
Overall width (without mirrors)	2570 mm	101.2
Overall height	3214 mm	126.5 in
Ground clearance	565 mm	22.2 in
Shipping height (with dump body)	3213 mm	126.5 in
Shipping width (with dump body)	2562 mm	100.8 in
Dump body		
Capacity heaped	6.5 m ³	8.5 y ³

Performance		
Curb weight (basic vehicle)	16524 kg	36430 lb
Payload	13200 kg	29100 lb
Maximum speed unloaded	13 km/h	8 mph
Fording depth	1199 mm	47.2 in
Turning radius	0 m	0 ft
Ground pressure (6 in. penetration)		
Basic vehicle	279 g/cm ²	3.97 psi
Loaded vehicle	524 g/cm ²	7.46 psi
Gradeability		
Uphill / Downhill (loaded)	15 deg	
Sidehill (loaded)	15 deg	

Engine		
Make	Caterpillar	
Model	C7.1 Acert	
Type	Turbo diesel, electronic fuel system	
Emission standard	EPA Tier 4 Final, EU stage IV	
Aftertreatment		
Clean Emission Module components	DOC, DPF and SCR	
Regeneration	Passive, transparent to the operator	
Number of cylinders	6 cylinders in line	
Displacement	7.01 L	427.7 in ³
Horsepower @ 2050 RPM	205 kW	275 HP
Torque @ 1400 RPM	1257 N•m	927 lb•ft
Ambient temperature operational limit	+46 °C	+115 °F
Cold start limit temperature with cold start option	-25 °C	-13 °F
Air cleaner	Double element dry type	
Glow plug starting aid	Yes	
Block heater	Yes	
Transmission		
Pump drive		
Type	Double pad	
Hydrostatic pumps		
Type	Axial piston pump, variable displacement	
Hydrostatic motors		
Type	Axial, variable displacement	
Gearboxes - end drive		
Type	Planetary gearbox	
Brakes (vehicle in motion)		
Type	Positive deceleration through the hydrostatic transmission	
Brakes (Parking)		
Type	Multi-disc, spring applied and pressure-released	
Control & Electronics		
Type	Microprocessor with colour display	
Inputs	Steering wheel, Forward-Neutral-Reverse switch and progressive throttle/speed pedal	
Outputs	Independent control of each track	
Other feature	Anti-stall and auto-calibration	
Automatic steer correction	Yes	
Communication	J1939	

TECHNICAL DATA

Electrical		
Alternator	12 V, 150 amps	
Battery	2 x 1150 CCA	
Master cutoff switch	YES	
Suspension		
Type	Tandem suspension	
Wheels and top rollers		
Quantity	16 (half wheels) and 2 top rollers (one per side)	
Type (wheels)	solid casting	
Dimensions (wheels)	120 mm x 610 mm	4.72 in x 24 in
Tracks		
Type	Metal embedded rubber track (endless)	
Width	750 mm	29.5 in
Tensioner	Automatic hydraulic track tensioning	
Chassis		
Type	Tube type	
Skid plate	None	
Capacities		
Cooling system	33 L	8.7 US gal
Fuel tank	300 L	79 US gal
DEF/AdBlue® tank	27 L	7.1 US gal
Engine crankcase	18 L	4.6 US gal
Hydrostatic oil tank	140 L	37 US gal
Planetaries (propulsion)	2.4 L each (3.0 L each at initial fill)	0.63 US gal (each)
Planetary (frame rotation)	4.4 L	1.16 US gal
Brake (frame rotation)	0.4 L	0.11 US gal
Pumps drive (splitter box)	1.4 L	0.36 US gal
Windshield washer tank	4 L	1.1 US gal
Idler wheel hubs	0.6 L (each hub)	21 oz (each hub)
Wheel hubs	0.9 L (each hub)	30 oz (each hub)
Top roller hubs	0.2 L (each hub)	7 oz (each hub)

Fluid types	
Fuel	ULSD (Ultra Low Sulfur Diesel) fuel with 0,0015% sulfur 15 ppm (mg/kg) or less ASTM D975 (US spec) or EN 590 (European spec)
DEF / Adblue®	In compliance with ISO 22241-1 standard, AdBlue in Europe
Engine coolant NOTE : 50% water, 50% antifreeze for temperature below -31 °F (-35 °C). Contact the Prinoth service department	Preferred: CAT ELC (Extended Life Coolant) Acceptable: CAT DEAC (Diesel Engine Antifreeze/Coolant) or a commercial heavy duty coolant that meets ASTM D4985 (use supplement coolant additive SCA at initial fill) or a commercial heavy duty coolant that meets ASTM D6210 (no supplement required)
Engine crankcase oil	CAT DEO-ULS (Diesel Engine Oil - Ultra Low Sulfur), Oil specification: API CJ-4, ECF-3, AECA E9
Planetary oil	Synthetic gear oil on PAO base (poly-alpha-olefin) ISO viscosity grade 220 DIN 51517-3 CLP
Pumps drive oil (splitter box oil)	Synthetic gear oil on PAO base (poly-alpha-olefin) ISO viscosity grade 220, SAE viscosity 75W 90 or 75W 140, API GL-4 or GL-5 or DIN 51517-3 CLP
Hydrostatic/hydraulic oil NOTE: VG 32 : -25 °C (-13 °F) / +25 °C (+77 °F) VG 46 : -10 °C (+14 °F) /+46 °C (+115 °F)	Mineral oil : DIN 51524 (HVLP), viscosity grade 32 or 46 ATF oil : Dexron III, Dexron II, Type F, Type A suffix A Biodegradable oil : Panolin HLP Synth 46, York Bio VG 46
Swing system - gearbox oil	Synthetic gear oil on PAO base (poly-alpha-olefin) ISO viscosity grade 220, SAE viscosity 75W 90 or 75W 140, API GL-4 or GL-5 or DIN 51517-3 CLP
Swing system - brake oil (wet brake) NOTE: VG 32 : -25 °C (-13 °F) / +25 °C (+77 °F) VG 46 : -10 °C (+14 °F) /+46 °C (+115 °F)	Mineral oil : DIN 51524 (HVLP), viscosity grade 32 or 46 ATF oil : Dexron III, Dexron II, Type F, Type A suffix A Biodegradable oil : Panolin HLP Synth 46, York Bio VG 46
Wheel and idler wheel hub oil	Synthetic gear oil on PAO base (poly-alpha-olefin) ISO viscosity grade 220, SAE viscosity 75W 90 or 75W 140, API GL-4 or GL-5 or DIN 51517-3 CLP
Top roller oil	Synthetic gear oil on PAO base (poly-alpha-olefin) ISO viscosity grade 220, SAE viscosity 75W 90 or 75W 140, API GL-4 or GL-5 or DIN 51517-3 CLP

Noise emission values

Sound power level (2000/14/EC, ISO 3744) *	105 dB (A)
Sound pressure level at the operating position (ISO 6396: 2008) *	77 dB (A)

Vibration emission values

Hand-arm-vibration (2002/44/EC, ISO 5349-2: 2001) **	< 2,5 m/s ²
Whole body-vibration (2002/44/EC, ISO 2631-1:1997) **	< 0,5 m/s ²

NOTE : Changes in design and specifications and/or additions or improvements in product may occur without any obligation to install them on previously manufactured vehicles. All quantities indicated are approximate. All products and company names are trademarks™ or registered® trademarks of their respective holders. Use of them does not imply any affiliation with or endorsement by them.

* The stated noise emission values have been measured on a standard vehicle without any custom equipment installed. Use these values only as indications. The custom equipment fitter has the obligation of measuring noise emissions of vehicle with equipment installed before it is put in service, and declare conformity where appropriate as per the 2000/14/CE directives.

** The stated vibration emission values have been measured on standard vehicles (without equipment) under particular operating conditions and terrain.

TECHNICAL DATA

DIMENSIONS

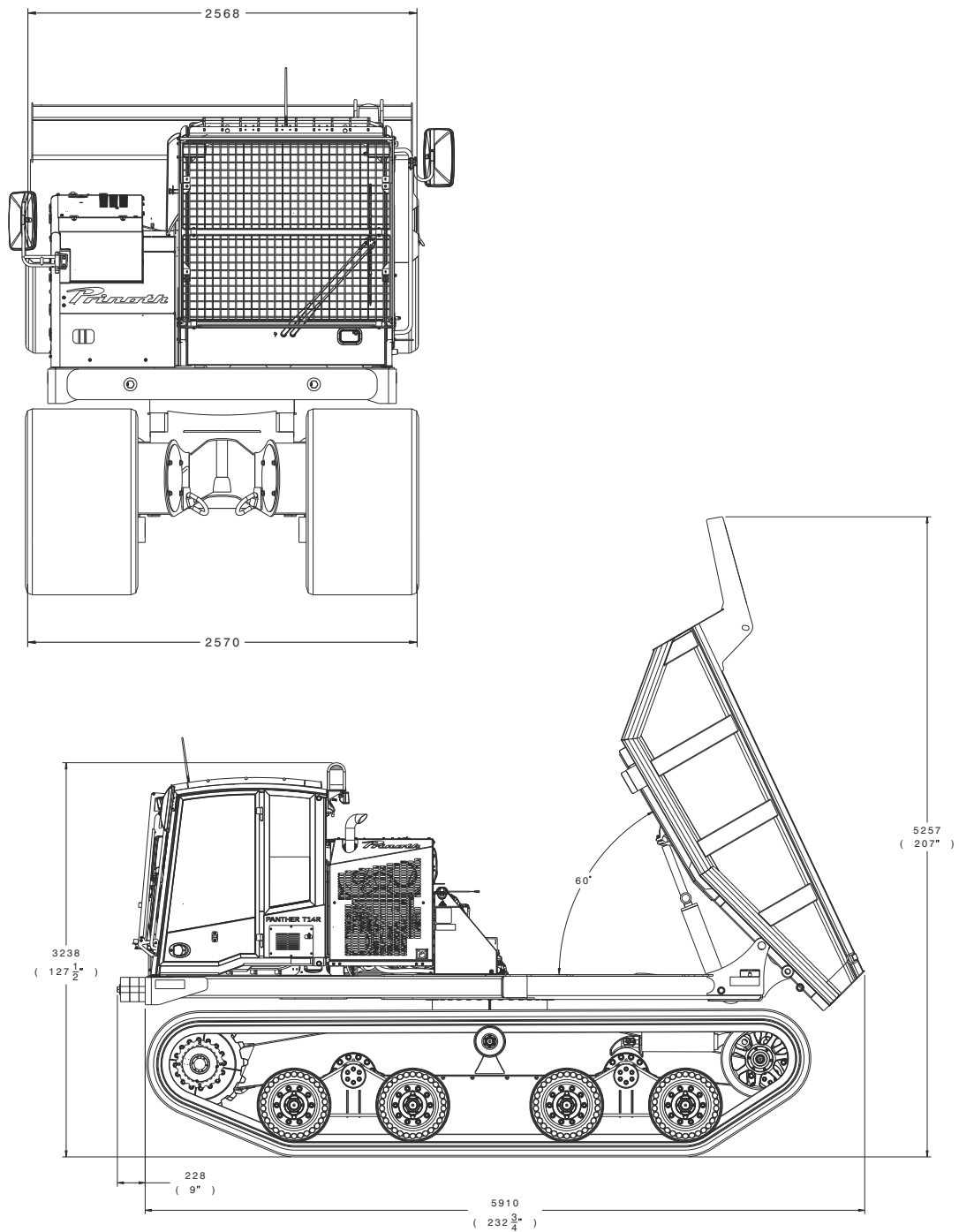

4119450015

Figure 183
Dimensions are in millimetres (approximate - vehicle shown with some options)

RETRIEVAL POINT

Use the circular beam at the back of the vehicle as the retrieval point. Set a length of chain around the beam and pull the vehicle while using caution.

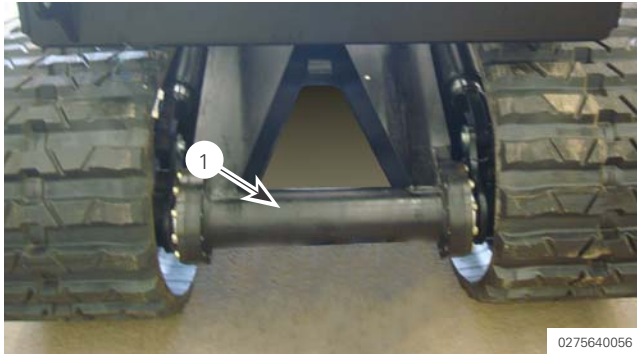

Figure 184

1. Retrieval point of the Panther

Keep towing distance and speed to the minimum to prevent accident and damage to the drive system.

⚠ WARNING

Impact, pinch and crush hazard
Never tow a vehicle with someone aboard.
Before proceeding, establish a safety zone around the vehicle to avoid injuries if the vehicle or its load slides, flips or crashes. A vehicle towed could lose its braking capacity.

Refer to "Towing" for details and safety precautions before proceeding.

NOTICE

Always use the retrieval point to move or tow the vehicle on a short distance. Using any other point on the vehicle could result in permanent damage to the structure or other components.

Towing distances should be short. For long distances, secure the vehicle on a suitable trailer.

JACKING POINTS

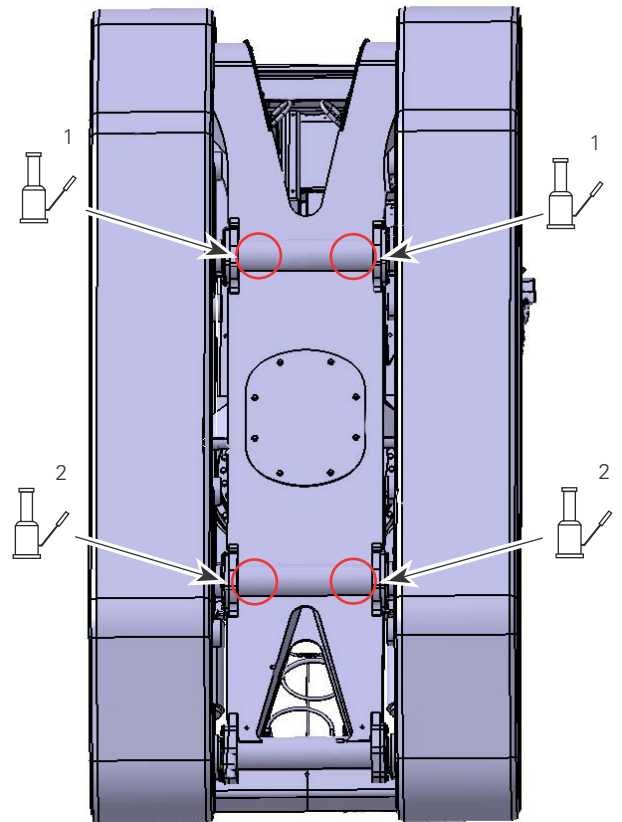

Figure 185

1. Jacking points at front of frame
2. Jacking points at rear of frame

⚠ WARNING

Crush and collapse hazard
Applying substantial weight to one side of the vehicle could cause it to fall off the jacks and cause severe injuries or death.
Do not start the engine and do not rotate the upper frame and do not raise the dump body once the vehicle is set on jacks.
Always set a safety perimeter around the vehicle once it is installed on jacks.

Refer to the previous figure to position the jacking devices underneath the frame.

Take all required precautions to ensure the vehicle is stable and that its moving parts remain immobilized at all times.

TECHNICAL DATA

TRANSPORT PREPARATION

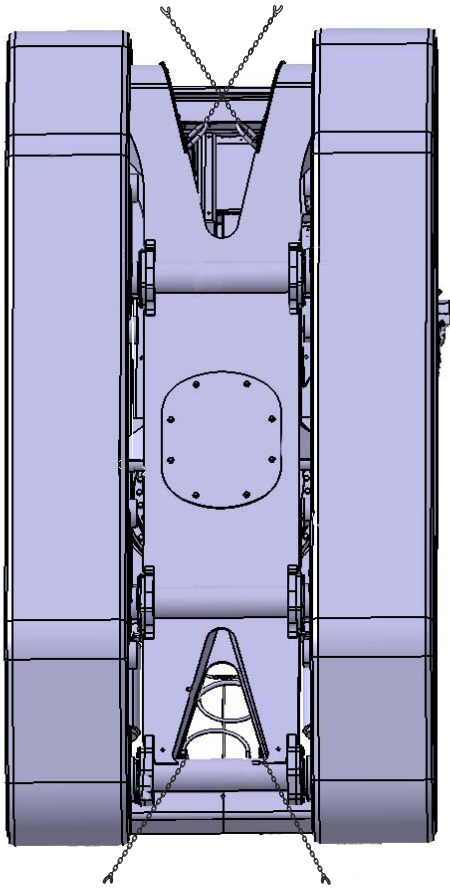

Figure 186

Tie down points - view from underneath the frame

0275640074

⚠ WARNING

Crush hazard

Never use the “D” rings to lift, move or tow the vehicle. It could move unexpectedly, turn over, or crash causing severe injuries or death.

At the front, when tying down the vehicle during transport, it is recommended to attach the chains to the “D” rings in an “X” pattern at the front to ensure maximum stability.

At the back, pass the chains around the cylindrical beam and secure to the ground or platform.

Use strong chains to secure the vehicle.

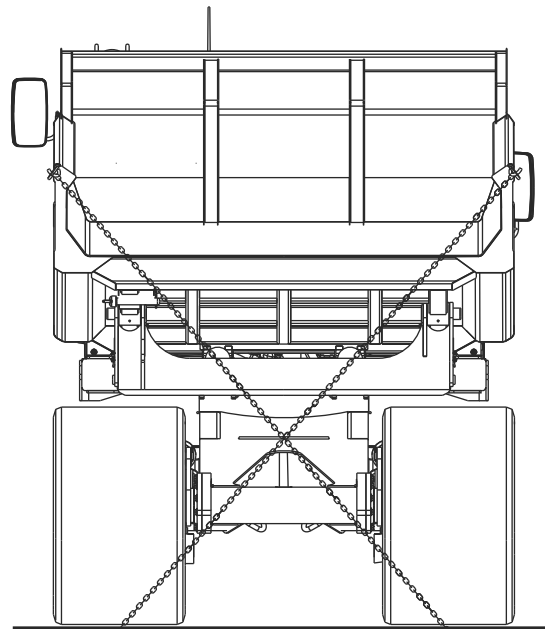

1105340025

Figure 187

Chains in an X pattern to secure the upper frame

⚠ WARNING

Accident hazard

If the brake of the rotation system slips or fails and the upper frame of the vehicle is not secured, the upper section could rotate and hit objects, vehicles or personnel nearby. Always secure the upper frame before transporting the Panther T14R on a platform, a trailer or other.

Before transporting the vehicle on a flat bed or other transport system, it is recommended to secure the upper frame to prevent an unwanted rotation.

Use chains to keep the upper frame from rotating. Install them so they do not cause damage to the tracks, the frame or other vehicle components.

Additionally, always ensure that the dump body is fully lowered, empty and that nobody is present in the cab. Observe the tie down point guidelines so the vehicle is secure on the transport platform.

GENERAL MAINTENANCE GUIDELINES

INTRODUCTION

This section describes basic maintenance procedures and simple troubleshooting to be accomplished for the normal operation of the vehicle. It does not include repair, adjustment or advanced troubleshooting procedures.

The tasks described in this section can be accomplished by a person with a good general knowledge of heavy equipment or machinery and standard tools.

Refer to the “**Maintenance Schedule**” section for frequency of periodic maintenance.

Some items or components shown in the maintenance sections may be optional or installed only on vehicles intended for specific countries or regions.

SAFETY

Maintenance work requires the following protective equipment and precautions:

- » Safety glasses;
- » Gloves;
- » Safety shoes;
- » Protective clothing (coverall);
- » Hard hat and ear protection if required;
- » Remove jewels, loose clothing and attach long hair.

Maintenance work requires observation of numerous safety precautions to minimize the risk of injuries. Refer to the SAFETY section of the present manual for safe practices.

Do not install equipment or disable devices that could impair safety of the operator or service personnel.

⚠ WARNING

Burn hazard
Hot oil and hot components can cause severe burns. Do not allow hot oil or hot components to contact the skin.

Oil under pressure, hot oil
Oil escaping under pressure can penetrate skin and cause severe injuries or burns. Release pressure and use protective clothing or equipment before servicing the hydraulic/hydrostatic system.

⚠ WARNING

Poisoning hazard
Operating fluids (and gases) are hazardous to health. Touching or swallowing operating fluids can cause caustic burns or poisoning. In case of contact or ingestion, get medical attention immediately. Always work in a well ventilated area.

⚠ WARNING

Fire hazard
Operating fluids and their vapour can be flammable. Do not bring open fire or allow sparks in the vicinity.

⚠ WARNING

Burn and fire hazard
Battery cells contain hydrogen, a highly combustible gas and sulfuric acid, a corrosive fluid. To avoid injuries:

Keep flames and sparks away from the battery.

Prevent contact between battery fluid and skin, eye, clothing and vehicle.

If battery acid comes in contact with the skin or eyes, immediately flush the area with large amount of fresh water, then get medical attention right away.

Observe safe work practices, read safety labels and review procedures before executing them.

GENERAL MAINTENANCE GUIDELINES

HOW TO WASH AND CLEAN THE VEHICLE



Do not use strong products, chemicals or solvents to clean the vehicle. Best results will be obtained with water or water with a small quantity of a mild soap. Rinse thoroughly after washing.

NOTICE

If the dump body is loaded with material such as salt, ammonium sulphate, potassium chloride, potassium sulphate or phosphates, the dump body, frame and tracks should be washed thoroughly after each work shift.

The rubber track is made of a rubber compound and should not be exposed for long periods to chemicals or solvents that could react with it and weaken or damage it. Apply the same precautions for the dump body.

Do not spray water directly on electrical components when washing the vehicle. Cover the following parts to prevent water from getting on them:

- » starting motor;
- » alternator;
- » sensors;
- » PETU;
- » aftertreatment components;
- » electrical connectors around the engine;
- » batteries, relays, fuses.
- » cab interior.

To clean inside the cab, moisten a cloth with warm water and soap, wring the cloth and just wipe the surfaces. Repeat without soap to rinse. Water sensitive areas can be cleaned with compressed air, either from a can of compressed air or from a pressure pipe.

ENGINE AND SYSTEM MAINTENANCE

AFTERTREATMENT AND REGENERATION

The aftertreatment unit works in conjunction with the diesel engine to meet U.S. Environmental Protection Agency (“EPA”) Tier 4 Final regulatory requirements and European Union (“EU”) Stage IV non-road mobile machinery emissions legislation.

The aftertreatment and exhaust system are not to be modified in any way or else the low emission certification will become invalid. All replacement parts must be genuine Prinoth parts.

CEM

The Clean Emission Module (CEM) generates the chemical reactions to reduce the engine emissions.

On the aftertreatment unit (see next figure), only the injector and the sensors can be replaced, all other components are non-serviceable.

NOTICE

Do not modify, tamper or customise the aftertreatment assembly or flex pipe components as supplied by Prinoth. Painting of any aftertreatment component is prohibited.

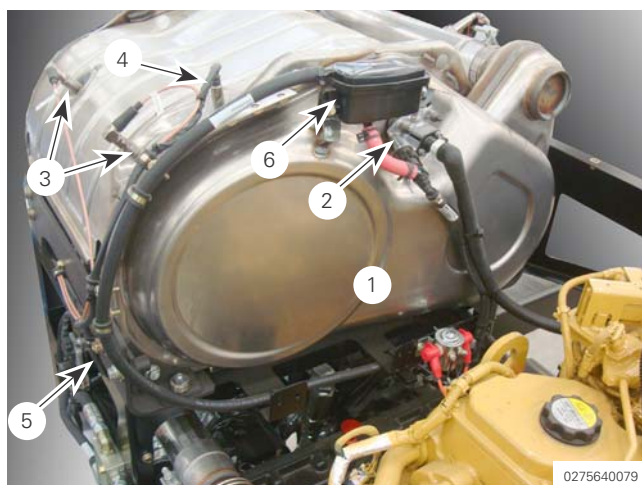

Figure 188

1. Aftertreatment unit
2. DEF/AdBlue® injector
3. Soot sensors
4. NOx / NH3 sensors (some not visible on picture)
5. Temperature sensors (not visible on picture)
6. Coolant fluid reservoir for the aftertreatment unit

Regeneration

Regeneration is the cycle where the burning of particulate matter occurs to clean the Diesel Particulate Filter of diesel engines.

The automatic maintenance regeneration does not require any intervention from the operator.

DEF/AdBlue® and PETU

The DEF/AdBlue® (Diesel Exhaust Fluid), is a solution containing urea, used in the aftertreatment unit. The Pump Electronics Tank Unit (PETU) is the component that stores and doses the quantity of DEF/AdBlue® to inject in the aftertreatment system (among other functions). Refer to “TECHNICAL DATA” on page 114 for information on the recommended fluid.

CAUTION

Mild irritation hazard

Contact with DEF/AdBlue® can cause eye and skin irritation. Do not breathe vapour or mist, do not eat, drink or smoke when using this product. Avoid contact with eyes, skin and clothing. Wash thoroughly after handling.

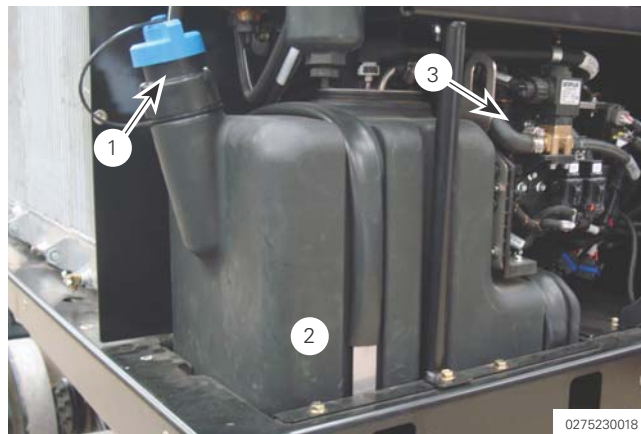

Figure 189

1. Filler neck and cap (colour coded light blue)
2. DEF/AdBlue® tank
3. Electronic pump and dosing unit

Filler neck and cap with filtered vent

The DEF/AdBlue® tank cap (light blue colour coded) incorporates a 100 micron filter and is designed specifically to only fit on the DEF/AdBlue® tank and not on any other type of tank.

An overfill protection device is incorporated into the filler neck.

ENGINE AND SYSTEM MAINTENANCE

DEF/AdBlue® Filling

NOTICE

DEF/AdBlue® is corrosive to some metals. Any spill should be cleaned immediately.

The 19 mm neck size prevents a standard diesel or gasoline fill nozzle from being inserted into the tank and a resulting miss fill.

Consult the LCD display in the cab to monitor DEF/AdBlue® quantity and refill as required.

Refill should be done every two or three times the diesel fuel tank is filled. Check the level at each refuel of the diesel tank. Engine power adjustment and eventual shut down will occur in the event of insufficient or poor quality DEF/AdBlue® supply.

Overfill and Freezing Protection

The DEF/AdBlue® tank requires an expansion volume be maintained for when DEF/AdBlue® freezes in cold weather. An expansion volume of approximately 10% must be maintained. Overfilling of the tank will result in tank rupture upon freezing.

Overfill protection is provided by the design of the tank, allowing the flow to back-up into the nozzle and activating its auto shut-off. After the nozzle is shut off, a weep hole in the adapter will allow the DEF/AdBlue® to slowly settle out of the adapter down into the tank. If the operator then tops off the tank it will be subject to freeze expansion risk. **The operator should NEVER top off the DEF/AdBlue® tank.**

NOTICE

Freezing hazard

Wait 2 minutes before turning off the battery isolator switch after the diesel engine shut down. If the battery isolator switch is turned off immediately, the DEF/AdBlue® could be trapped in hoses and freeze in cold temperature, causing damage to the system components.

DEF/AdBlue® trapped in hoses could freeze and damage the PETU. Always take precautions to prevent damage and emission problems.

DEF/AdBlue® filter replacement



Figure 190

1. DEF/AdBlue® tank assembly
2. DEF/AdBlue® filter cap



0275230046

Figure 191

DEF/AdBlue® filter (left) and expansion device (right)

The PETU contains a serviceable filter (which has to be replaced every 5000 hours). Access to the filter assembly requires the removal of the front cowling panel. Ensure to empty the tank before proceeding with the filter replacement.

To remove the filter cap, use a 27 mm Bi-Hex socket tool.

Remove the expansion device inside the filter element using the tool supplied with the new filter. Remove and discard the used filter.

Install the new filter, expansion device and filter cap.

Tighten the filter cap to 20 N•m (15 ft-lb).

Maintain the quality of the DEF/AdBlue®

The quality of DEF/AdBlue® is critical. Handling and storage must be tightly controlled. These precautions are necessary to:

- » • maintain shelf life;
- » • prevent injector clogging;
- » • prevent formation of deposits;
- » • prevent poisoning of the catalyst.

Tank cleaning

To clean the tank, reverse flush with distilled or de-ionized water through the drain, then flushed with fresh DEF/AdBlue® just before use. For detailed maintenance of the DEF/AdBlue® tank please refer to the engine Operating and Maintenance Manual of the engine supplier.

Tank drain orifice

Use the tank drain orifices for any dirt, debris, deposits or poor quality DEF/AdBlue® that may enter the tank to be flushed out. Poor quality DEF/AdBlue® may occur by tank miss fill or poor storage control.

Long-term storage

The DEF/AdBlue® tank should be drained before long term storage of the vehicle.

Engine power adjustment or shutdown

The engine control system (ECM) is designed to monitor each engine and aftertreatment sensor/actuator and react to system critical or emissions critical failures. When a system error occurs, such as high engine coolant temperature, the engine monitoring system reacts by raising the appropriate engine diagnostic level and in some cases forces the engine into a power adjustment condition or controlled shutdown.

Warning

The Engine Monitoring warning is always active and can not be disabled. Activation of this engine monitoring option ensures that upon the engine measuring an engine parameter above the threshold level a warning is triggered (Event Code), which is logged by the engine ECM and the appropriate icon on the display appears.

Power adjustment

Each monitored parameter that uses the power adjustment function has its own trigger threshold and map. If the threshold is equaled or exceeded by any parameter, a power adjustment protection will be set active and the engine power will be adjusted. The ECM will log these events and turn on the appropriate icon on the display. The level of engine power adjustment will vary depending upon the parameter being monitored.

Shutdown

The engine shutdown indication icon will be triggered when any parameter equals or exceeds its shutdown threshold for a time exceeding its shutdown indication guard time. Physical engine shutdown will occur only if enabled by the parameter. The ECM will log these events and turn on the appropriate icon on the display.

ENGINE AND SYSTEM MAINTENANCE

ENGINE OIL

Oil used in the engine must be approved by the engine supplier. For complete and detailed information on oil refer to the engine supplier documentation.

Change the engine oil and filter every 500 hours of operation.

Refer to "TECHNICAL DATA" on page 114 for information on the recommended oil.

NOTICE

Using oil that is not recommended can cause premature wear and void the warranty.

Lubricant Viscosity Recommendations

The proper SAE viscosity grade of oil is determined by the minimum ambient temperature during cold engine start-up, and the maximum ambient temperature during engine operation. Refer to the following table to select the proper grade.

Tier 4 engine oil viscosity for ambient temperatures		
Viscosity grade	Ambient temperatures	
	Minimum	Maximum
SAE 0W30	- 40°C (- 40°F)	30°C (86°F)
SAE 0W40	- 40°C (- 40°F)	40°C (104°F)
SAE 5W30	- 30°C (- 22°F)	30°C (86°F)
SAE 5W40	- 30°C (- 22°F)	50°C (122°F)
SAE 10W30	- 18°C (0°F)	40°C (104°F)
SAE 10W40	- 18°C (0°F)	50°C (122°F)
SAE 15W40	- 9,5°C (15°F)	50°C (122°F)

Oil Analysis

It is recommended to collect oil samples and perform analysis to monitor oil degradation and detect early signs of wear on internal components. An oil sampling valve on the oil filter base is provided for that purpose. Oil sampling intervals should be 250 hours of operation.

The oil filter can also be cut open to detect and analyse of metal debris.

OIL AND FILTER CHANGE PROCEDURE

Change the engine oil and filter cartridge at the same time. Proceed when the oil is warm to ensure that waste particles drain thoroughly.

- » Using the proper equipment, thoroughly clean the underside of the vehicle in the engine area.
- » Bring the vehicle on a flat and level surface. Install wood blocks to prevent the tracks from moving.
- » If accessing the oil filter from under the engine, place the vehicle in the normal configuration (planetary gearboxes under the cab and cowling), then, rotate the upper frame to bring the front left corner between the two tracks as shown.



Figure 192
How to position the upper frame for the procedure

- » Turn off the engine. Remove the key from the ignition switch.
- » Release tension on the tracks to provide space under the engine.

NOTE : Release track tension to gain access under the upper frame.

⚠ WARNING

Crush hazard

Unintended activation of the vehicle engine or the track tension could cause serious injury or death. Ensure the engine is off, the master switch is off, the cab door is locked and a lock-out tag is installed.

- » Turn off the battery isolator switch and install a padlock on the switch. Install a lockout tag on the door.

⚠ WARNING

Burn hazard

Hot oil and hot components can cause severe burns. Do not allow hot oil or hot components to contact the skin.

- » Access the drain valve of the engine oil pan.
- » Install a flexible tube onto the valve and position a recipient underneath to collect the waste oil.

Drain oil from the diesel engine

- » Remove the cap of the oil filler neck on top of the engine.

ENVIRONMENTAL PROTECTION : Dispose of engine oil according to prevailing legal requirements.

- » Turn the valve handle counterclockwise and allow the oil to drain.

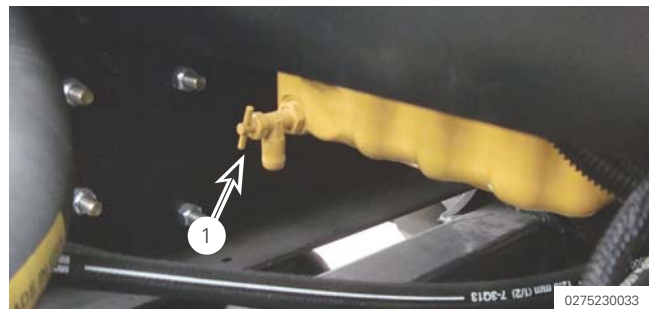

Figure 193
1. Oil drain valve

- » When the oil is completely drained, close the valve and remove the flexible tube.

ENGINE AND SYSTEM MAINTENANCE

Replace the oil filter

- » Gain access to the oil filter cartridge.
- » Unscrew the filter canister from filter head by hand or using a strap wrench.

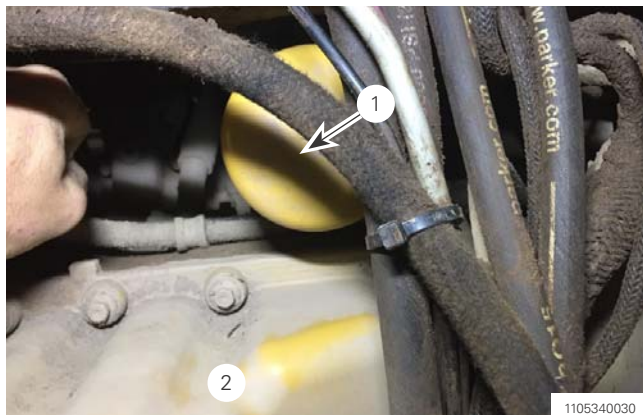

Figure 194

1. Engine oil filter cartridge
2. Engine oil pan

ENVIRONMENTAL PROTECTION : Dispose of engine oil according to prevailing legal requirements.

- » Discard the old filter canister.
- » Clean the sealing surface of the filter mounting head.
- » Apply clean engine oil to the O'ring seal of the oil filter canister. Do not fill the filter before installation, as unfiltered oil may introduce contamination in the system.
- » Install the new oil filter. Spin the new oil filter cartridge until the O'ring seal contact the mounting head. Then rotate the oil filter 3/4 of a turn.

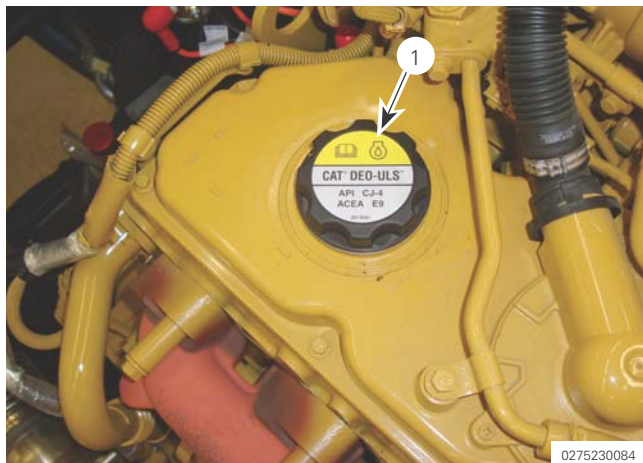

Figure 195

1. Engine oil filler and cap

Fill engine with new oil

- » Fill the engine with the recommended oil by the oil filler neck. Check the level with the dipstick. Do not overfill. Refer to "TECHNICAL DATA" on page 114 for information on the recommended oil.

NOTICE

Do not overfill the engine crankcase with oil. A higher level of oil will cause problems.

- » Re-install the oil filler cap on the engine.
- » Remove the padlock and turn on the battery isolator switch. Set the track tension knob(s).
- » Start the engine and run at low idle for two minutes.
- » Stop the engine and wait ten minutes. Then, check the oil level and adjust if required.



Figure 196

1. Engine oil dipstick

- » Inspect the oil filter for leaks.

CHANGING THE ENGINE COOLANT

Engine coolant

Refer to “TECHNICAL DATA” on page 114 for the recommended engine coolant fluid.

NOTICE

Using a coolant fluid that is not recommended can cause premature wear and void the warranty.

Do not use automotive grade coolant fluid, use only coolant approved by the engine supplier.

It is recommended (but not mandatory) to collect coolant samples and perform analysis to monitor its condition. The goal is to optimise the life of the coolant while preventing potential problems as well as warranty issues caused by deficient maintenance.

- » Samples for Level 1 analysis will test the properties of the coolant fluid. Perform Level 1 analysis every 250 hours.
- » Samples for Level 2 analysis will test the chemical evaluation of the coolant fluid and provide information on the condition of the cooling system. Perform Level 2 analysis yearly.

NOTE : Refer to your authorized Caterpillar representative for more details on the sample analysis program.

Coolant fluid replacement procedure

NOTE : Vehicle must be on level ground whenever the cooling system is serviced.

NOTE : Vehicle must be on level ground whenever the cooling system is serviced.

Inspect the water pump and the water temperature regulator after the cooling system has been drained. This inspection is a good opportunity to replace the water pump, the water temperature regulator, and the hoses, if necessary.

Clean the cooling system and flush the cooling system before the recommended maintenance interval if the following conditions exist:

- » *The engine overheats frequently;*
- » *Foaming is observed;*
- » *The oil has entered the cooling system and the coolant is contaminated.*

NOTE : When the cooling system is cleaned, only clean water is needed.

- » Turn off engine and allow to cool down.

WARNING

Burn hazard

Never remove the coolant reservoir cap when the engine is hot. To avoid severe burns, do not inspect the coolant system or attempt to add coolant if the engine is hot.

- » Using a clean rag, slowly open the cap on the filler neck of the engine coolant reservoir to release pressure. Ensure no contaminant enters the reservoir.

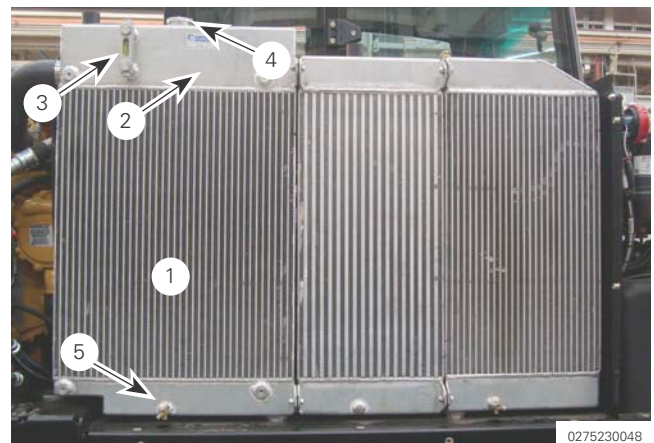

Figure 197

1. Engine coolant radiator core
2. Coolant reservoir
3. Coolant level sight glass
4. Radiator cap
5. Radiator drain valve

- » Gain access to the area of the drain valve. Install a flexible tube on the valve outlet.
- » Install a recipient to collect the existing coolant.
- » Open the valve. Wait until the cooling system is empty.

ENVIRONMENTAL PROTECTION : Dispose of engine coolant according to prevailing legal requirements.

- » Flush the cooling system with clean water to remove debris.
- » Close the drain valve of the radiator.

NOTICE

Fill the cooling system no faster than 5 L (1.3 US gal) per minute to avoid air locks.

- » Fill the system with a mixture of clear water and a cooling system cleaner (use a cleaner recommended by the engine supplier in the recom-

ENGINE AND SYSTEM MAINTENANCE

mended proportions). Re-install coolant reservoir cap.

- » Start and run the engine for 30 minutes as per engine supplier recommendations. Coolant temperature should reach at least 82° C (180° F)
- » Stop the engine and allow to cool.

ENVIRONMENTAL PROTECTION : Dispose of water and cleaner according to prevailing legal requirements.

- » Loosen the system filler cap to relieve pressure. Remove the cap.
- » Drain the cleaning mixture.
- » Flush the cooling system with clean water.
- » Close the valve and remove the flexible tube.
- » Fill the system with the recommended coolant fluid. Use the additive, if required, as per Caterpillar recommendation.
- » When the coolant has reached the recommended level in the reservoir, stop filling.
- » Start the engine and run at low idle. Increase engine speed in order to open engine thermostat. This will purge air from the cavities in the engine block. Decrease engine speed, then stop the engine.
- » Check engine coolant level. Maintain coolant level within the proper levels on the sight glass of the reservoir.
- » Wait until the system is cool. Clean and inspect reservoir cap. Replace if damaged or worn. Install it on the reservoir filler neck.
- » Start the engine. Re-check coolant level. Check for leaks and for proper operating temperature.

NOTE : Inspect the water pump and the water temperature regulator after the cooling system has been drained. Replace the water pump, the water temperature regulator, and the hoses if necessary.

CHANGING THE FUEL FILTERS

⚠ WARNING

Fuel under pressure

The fuel system operates at very high pressure. On the engine has stop running, wait 10 minutes for the pressure to dissipate before working on the system.

⚠ WARNING

Explosion hazard

Fuel is flammable and explosive under certain conditions. Fumes emanating from fuel could ignite and cause severe injuries or burns. Always take precautions to prevent fire/explosion and clean up spills immediately.

Take all necessary precaution to avoid igniting fuel or fumes and avoid skin contact with fuel as much as possible.

Changing the primary fuel filter (water separator)

To replace the filter cartridge, proceed as follows:

- » Turn off the battery isolator switch.
- » Gain access to the filter by opening the cowling panel.
- » If equipped, disconnect fuel heater electrical connector from clear bowl.
- » Install a recipient under the fuel filter/water separator to collect fuel.
- » Clean area around the filter.
- » Install a suitable tube onto the drain. Open the drain valve and drain the content of the clear bowl.
- » Loosen the vent screw on the filter head.
- » Allow fuel to drain in the recipient.
- » Tighten the vent screw and close the bowl drain valve. Remove the tube.

ENVIRONMENTAL PROTECTION : Dispose of diesel fuel according to prevailing legal requirements.

NOTICE

Do not allow dirt to enter the fuel system. Thoroughly clean the area around the fuel components. Fit a suitable cover on disconnected items.

- » Remove filter from head (unscrew assembly). Use a strap wrench if required.

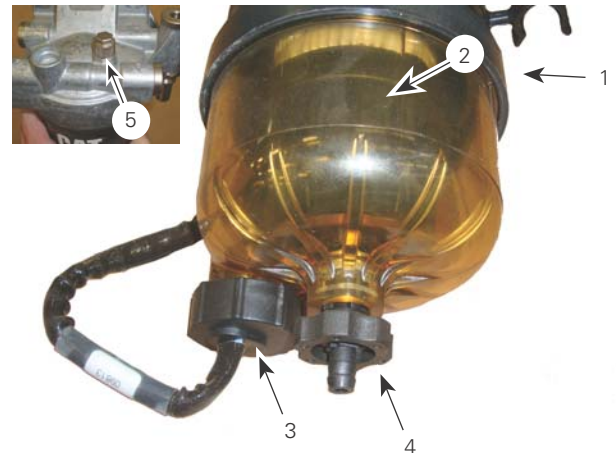

Figure 198

1. Primary fuel filter housing
2. Clear bowl
3. Fuel heater
4. Bowl drain valve
5. Vent screw on filter head

- » Discard existing filter cartridge.
- » Clean the clear bowl
- » To install the new filter, spin it on the drain valve threads inside the bowl. Ensure it is secure.
- » Lubricate the upper O-ring of the new filter with clean engine oil. Do not fill the bowl with fuel.
- » Install the new filter assembly on the filter head. Tighten by hand only.
- » If equipped, re-connect fuel heater electrical connector to clear bowl.
- » Proceed to change the secondary fuel filter.

Changing the secondary fuel filter

To replace the filter cartridge, proceed as follows:

- » Turn off the battery isolator switch.
- » Install a recipient under the fuel filter to collect fuel.

NOTICE

Do not allow dirt to enter the fuel system. Thoroughly clean the area around the fuel components. Fit a suitable cover on disconnected items.

- » Clean area around the filter.
- » Install a suitable tube onto the drain. Open the drain valve and drain the content in the recipient.
- » Wait until the housing is empty, then close the valve. Remove the tube.

ENGINE AND SYSTEM MAINTENANCE

ENVIRONMENTAL PROTECTION : Dispose of diesel fuel according to prevailing legal requirements.

- » Remove filter housing from head. Use a strap wrench if required.



Figure 199
1. Secondary fuel filter

NOTICE

Do not fill the secondary fuel filter with fuel before installing it. Fuel would not be filtered and could be contaminated.

- » Discard the used filter and spin the new one on the threads of the drain valve inside the filter housing.
- » Lubricate the upper top seal of the new filter cartridge with clean engine oil.

NOTICE

Do not fill the secondary fuel filter with fuel before installing it. Fuel would not be filtered and could be contaminated.

- » Install filter housing cartridge on filter head. Tighten by hand only.
- » Turn on the battery isolator switch.
- » Prime the fuel system as it was done for the primary fuel filter replacement.
- » Start engine and check for leaks.

Changing the in-line fuel filter

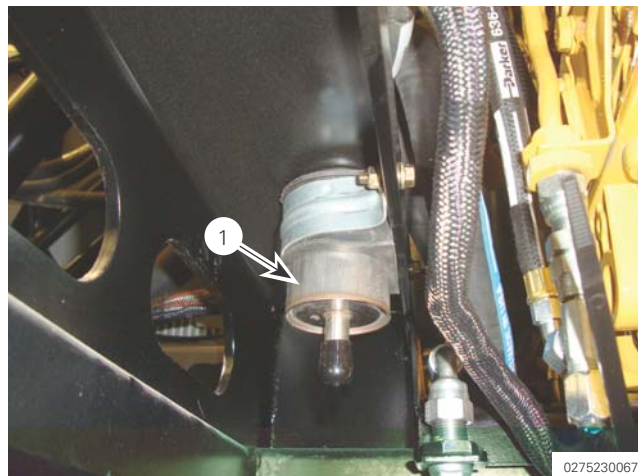

Figure 200
1. Fuel in-line filter

The in-line fuel filter must be replaced each time the primary and secondary fuel filters are replaced. Proceed as follows:

- » Gain access to the in-line filter. The filter is attached to the accessory support below the fuel priming pump.
- » Install a recipient under the filter to collect fuel.

ENVIRONMENTAL PROTECTION : Dispose of the diesel fuel according to prevailing legal requirements.

- » Open the fuel cap to release air pressure in the fuel tank circuit.
- » Remove the hose clips and remove the hose lines from the in-line filter. Remove the filter
- » Install the new in-line filter. Ensure the arrow mark is aligned in the direction of fuel flow from the tank to the fuel pump.
- » Re-install the hoses and hose clips.
- » Secure the in-line filter to the frame.
- » Prime the fuel system.
- » Check for leaks.

Priming the Fuel System



Figure 201
Fuel priming pump

Priming of the fuel lines and filters is performed by an electrical pump and is automatic.

The fuel system will be primed under the following conditions:

- » running out of fuel;
- » storage;
- » replacement of the fuel filter, of a part on the circuit or partial drain of fuel in the circuit.

To prime, proceed as follows:

- » Turn ignition switch to "Run";
NOTE : The switch will allow the electric pump to operate. The ECM will stop the pump after 2 minutes.
- » Turn ignition switch to "OFF";

NOTICE

Do not crank the engine for more than 30 second. Allow the engine to cool for two minutes before attempting to crank again.

- » Operate the engine starter and crank the engine. After, operate the engine for 5 minutes at low idle. Ensure the engine is running at stable idle and there are no leaks.

NOTICE

After engine is stopped, always wait at least 10 minutes to allow fuel pressure to be purged from the high pressure fuel lines before any service or repair is performed.

DRAINING THE FUEL TANKS

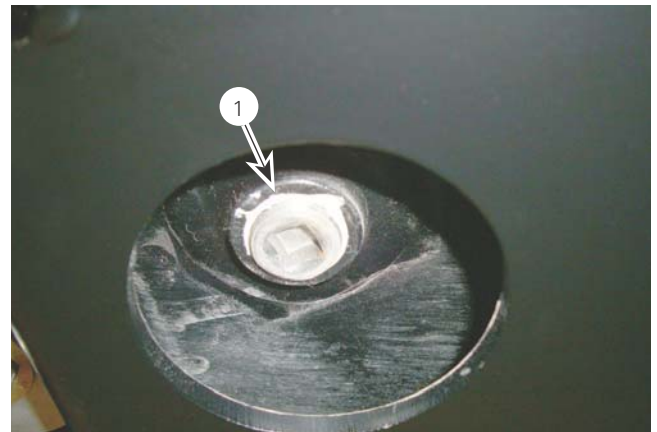

Figure 202
1. Fuel tank drain plug

Each fuel tank is equipped with a plug to drain water and sediment from its bottom.

- » Turn off the battery isolator switch.
- » Install a recipient under the drain plug of the tank.
- » Open the drain plug and wait until the water and sediments are drained from the tank.

ENVIRONMENTAL PROTECTION : Dispose of the diesel fuel according to prevailing legal requirements.

- » Clean and re-install the drain plug. Check for leaks.
- » Turn on the battery isolator switch.

FUEL SYSTEM VERIFICATION

⚠ WARNING

Fuel under pressure

The fuel system operates at very high pressure. On the engine has stop running, wait 10 minutes for the pressure to dissipate before working on the system.

Inspection of fuel lines, hoses, filters and system components should be undertaken periodically to check for wear and deterioration.

ENGINE AND SYSTEM MAINTENANCE

REPLACING THE CRANKCASE BREATHER FILTER CARTRIDGE

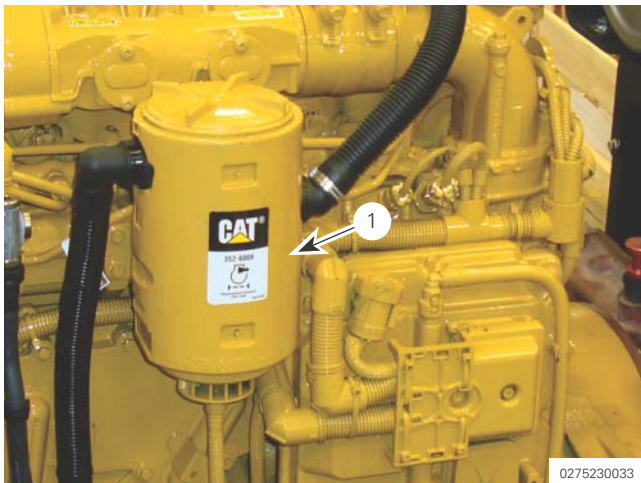

Figure 203

1. Housing of the crankcase breather filter

Replace the crankcase breather filter cartridge every 1500 hours. Ensure engine is stopped and cool.

Take all necessary precaution to avoid igniting fuel or fumes. Proceed as follows to work from the top of the housing:

- » Turn off the battery isolator switch.

NOTICE

Do not allow dirt to enter the system. Thoroughly clean the area around the filter canister. Fit a suitable cover on disconnected items.

- » Gain access by the oblong cavity on the top cowling panel or by removing the required cowling panels.
- » Clean area around the filter.

- » Remove the cover on the housing. Remove the filter cartridge.



Figure 204

1. Crankcase breather filter cartridge

- » Inspect and clean the filter housing interior surfaces.
- » Remove the old seal on the cover and install a new one.
- » Install the new filter cartridge while ensuring the correct position. Align the edge in the cover with the notch on the filter cartridge.
- » Reinstall the cover and tighten by hand.

ENVIRONMENTAL PROTECTION : Dispose of filter cartridge according to prevailing legal requirements.

- » Turn on the battery isolator switch.

REPLACING THE ENGINE AIR FILTER

NOTICE

Do not run the engine without an air filter. Dirt and debris could cause permanent damage to the engine.

If the clogged air filter fault shows that filter replacement is required, proceed as follows:

- » Position a small bowl under the dust purge valve. Squeeze the rubber valve to release the dust.
- » Unlatch and remove the cover on the filter housing.

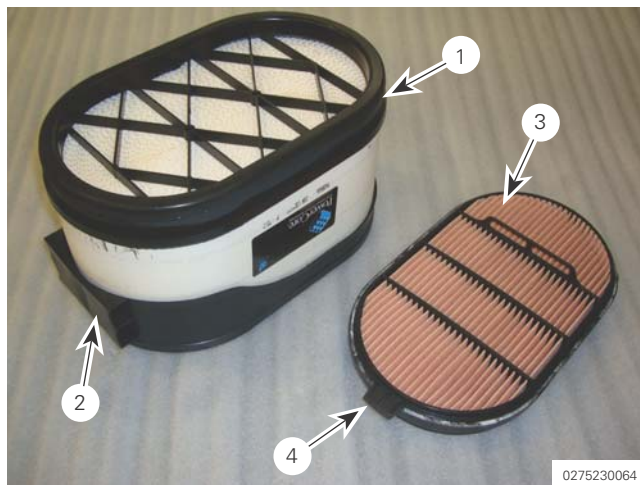

Figure 205

1. Main air filter element
2. Flat spot
3. Secondary filter element
4. Alignment tab

- » Remove the existing filters and discard them.
 - » Push the primary filter toward the empty space in the housing and then pull it out.
 - » Pull the primary filter toward the empty space in the housing and then pull it out.
- » Inspect and clean the interior of the filter housing.

NOTE : If the housing is to remain without a filter for a while or if air is dusty, plug interior cavities and re-install cover to prevent contamination.
- » If required, remove temporary material that was used to protect cavities from contaminant.
- » Install the new filters in the housing.
 - » Install the secondary filter first, the alignment tab toward the cavity at the bottom of the housing.
 - » Install the primary filter in the housing, the flat spot toward the cover.
- » Re-install the cover and engage the latches.

CLOGGED AIR FILTER INDICATOR

There is no visual indication on the air filter sensor itself, the signal of the switch is sent to the LCD display in the cab.

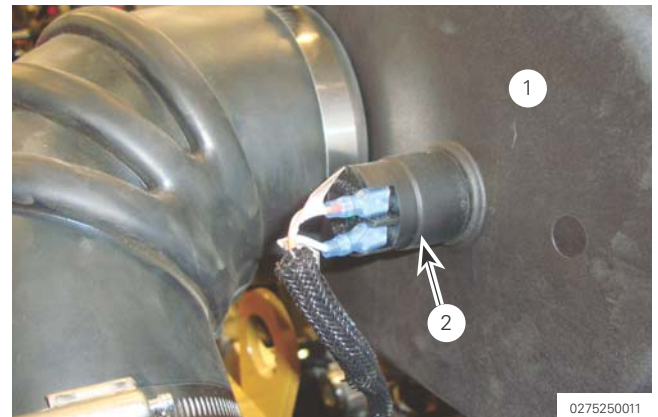

Figure 206

1. Air filter housing
2. Clogged air filter sensor

When restriction is detected in the filter, the display in the cab will show a red engine icon with a white arrow.



Figure 207

Red icon indicating restriction on the engine air filter

Operating in a Dusty Environment

If operating in a dusty environment, it is very important to ensure that dust and debris do not restrict cooling and normal engine operation. Keep all radiators and oil cooler clean as much as possible and ensure the engine air intake filter remains unobstructed. Learn to identify critical components, indicators and routinely perform maintenance procedures to avoid component overheating and engine problems.

ENGINE AND SYSTEM MAINTENANCE

INSPECTING THE COOLING SYSTEM

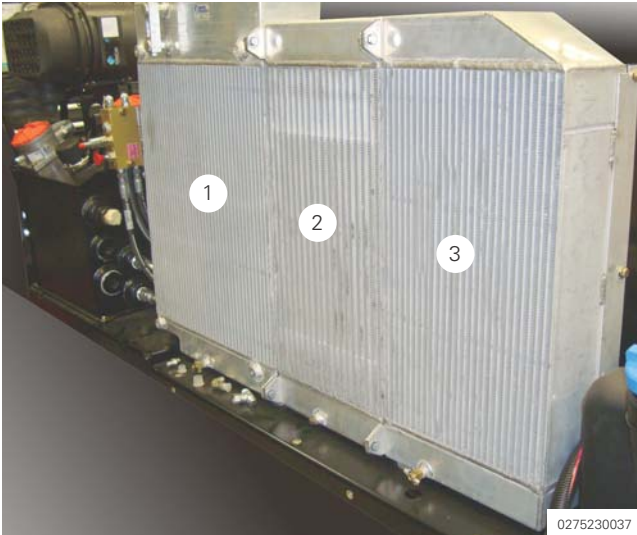

Figure 208

1. Coolant radiator
2. Air radiator
3. Oil cooler

Remove foreign bodies (dust, vegetation, etc.) from the radiator/cooler fins with a steam cleaner (max. 70° C or 160° F) or by blowing out with compressed air from the back of the radiator/cooler.

Inspect unit, drain valves, hoses and tubes and check for leaks. Replace worn or damaged parts.

INSPECTING THE ENGINE DRIVE BELT

- » Gain access to the area around the engine drive belt.



Figure 209

1. Engine drive belt

- » Inspect the belt for cracks, splits, glazing, grease, wear or deterioration. It should not be contaminated by grease, oil or other fluids. Replace the belt if required.

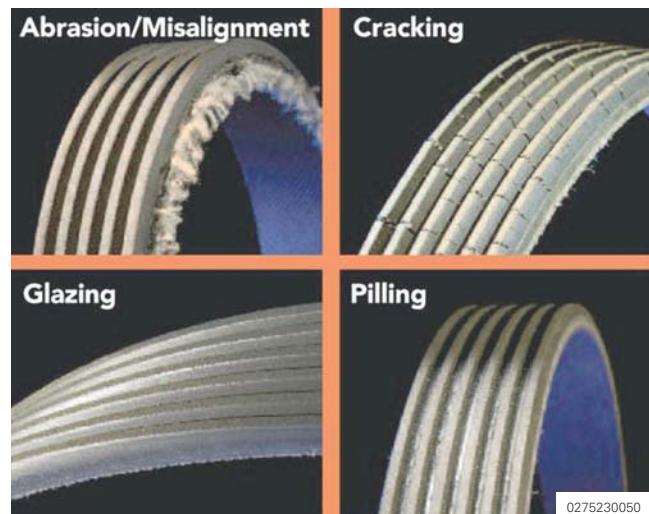

Figure 210

Example of wear/damage on the engine drive belt

- » If required, re-install hardware and cowling panel. Refer to the engine supplier for detailed information.

DRIVE SYSTEM MAINTENANCE

CHANGING THE OIL OF THE PUMP DRIVE

- » Remove the parts required to gain access to the pump drive.
- » Install a recipient under the pump drive to collect oil.
- » Open the drain plug under the housing. Wait until all oil is drained.

ENVIRONMENTAL PROTECTION : Dispose of hydrostatic oil according to prevailing legal requirements.



Figure 211

1. Pump drive drain plug (viewed from below)

- » Close the drain plug.
- » Remove the dipstick and fill the housing with new oil. Re-install the dipstick. Refer to "Vehicle Specifications" on page 114 for information on the recommended oil.
- » Check level with the dipstick as described in "Pump Drive Oil Level" of "PRE-OPERATION INSPECTION". Re-adjust the oil level if required.



Figure 212

1. Pump drive dipstick to measure oil level

- » Re-install the parts that were removed to gain access to the pump drive.

HYDROSTATIC OIL

Changing the hydrostatic oil, filter or component requires a subsequent system startup to purge the air introduced in the circuit by any of these procedures. Please refer to the training guide (or service guide) of the vehicle for details on the procedure.

Refer to "TECHNICAL DATA" on page 114 for information on the recommended oil. Refer to "Draining hose for Hydrostatic tank" on page 78 for information on the drain hose of the hydrostatic oil tank.

NOTICE

Using oil that is not recommended can cause premature wear and void the warranty.

Lubricant Viscosity Recommendations

The proper viscosity of oil is determined by the ambient temperature. Refer to "TECHNICAL DATA" on page 114 for information on the viscosity.

DRIVE SYSTEM MAINTENANCE

CHANGING THE OIL OF THE PLANETARIES

It is required to change the oil in the planetaries at regular intervals. To do so, proceed as follows:

- » Position the vehicle so the drain plug on the cover of the planetary is as shown on the next figure. Ensure the imaginary horizontal line is aligned with the bolts at the circumference.

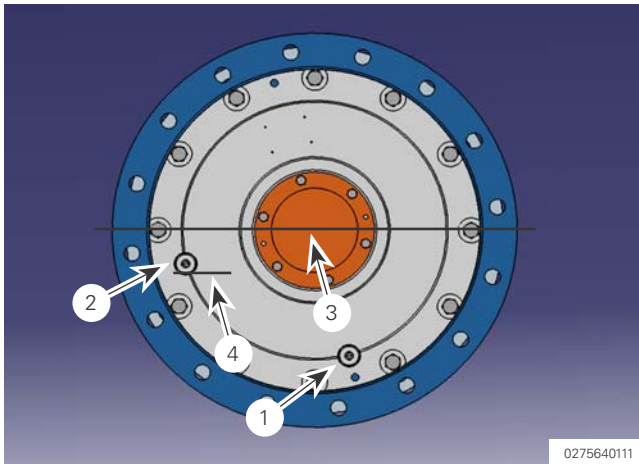

Figure 213

1. Fill / drain plug
2. Level plug
3. Imaginary housing center line (align with bolts)
4. Recommended oil level

- » Install a recipient under the planetary to collect oil.
- » Drain the oil by opening both plugs.

ENVIRONMENTAL PROTECTION : Dispose of oil according to prevailing legal requirements.

- » Using a new seal, re-install the bottom/drain plug.
- » Refill with the recommended oil until the level reaches the level plug. See Figure 213. Refer to "TECHNICAL DATA" on page 114 for information on the recommended oil. Do not overfill as this could lead to overheating and cause permanent damage. Ensure no foreign matter enters the housing as contamination could cause irreversible damage.
- » Using a new seal, re-install the level plug.
- » Repeat for the other planetary gearbox.

CHANGING THE OIL OF THE WHEEL HUBS

It is required to change the oil in the intermediate wheel hubs and the idler wheel hubs at regular intervals. To do so, proceed as follows:

- » Install a recipient under the hub to collect used oil.

ENVIRONMENTAL PROTECTION : Dispose of oil according to prevailing legal requirements.

- » If working on the idler wheel, loosen the hub cover (six bolts) and wait until the oil is drained. Then remove the six bolts and the hub cover.

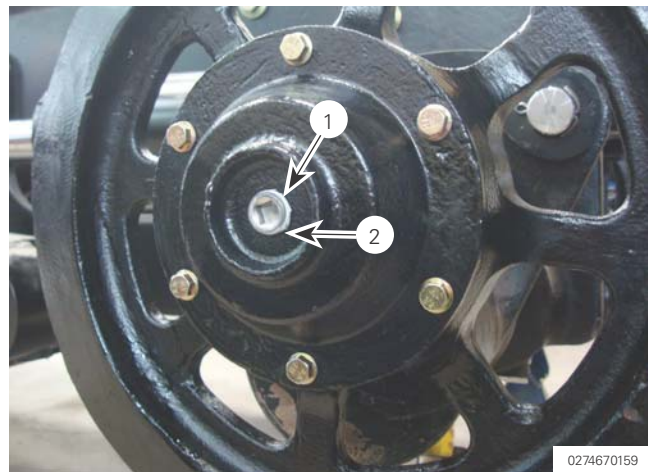

Figure 214

1. Wheel hub center plug (idler wheel hub shown)
2. Recommended oil level in the hub

- » If working on the intermediate wheel, remove both fill/drain plugs and wait until the oil is drained. Then clean and re-install the fill/drain plugs.

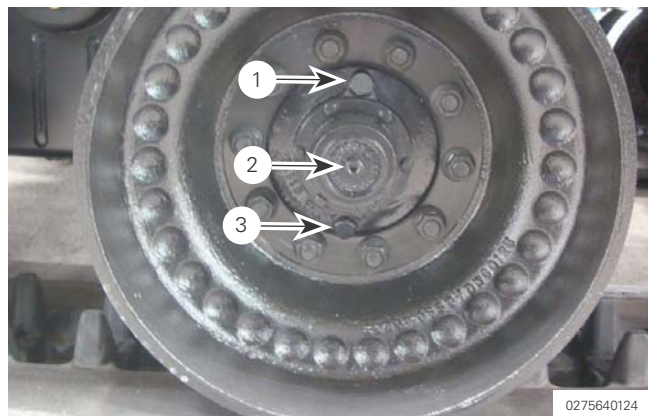

Figure 215

1. Fill/drain plug
2. Level plug
3. Fill/drain plug

- » On the idler wheel hubs, inspect the cover internal surface and the bearing exposed parts. Replace

worn or damaged parts. Remove and clean the center plug of the hub cover and clean the hub cover. Using a new O'ring, re-install the cover on the hub.

- » Using the center plug cavity, fill the hub to the recommended level with oil (see Figure 214). Refer to "TECHNICAL DATA" on page 114 for information on the recommended oil.
- » Clean and re-install the center plug on the hub using sealing compound.
- » Repeat for the other hubs.

CHANGING THE OIL OF THE TOP ROLLER HUBS

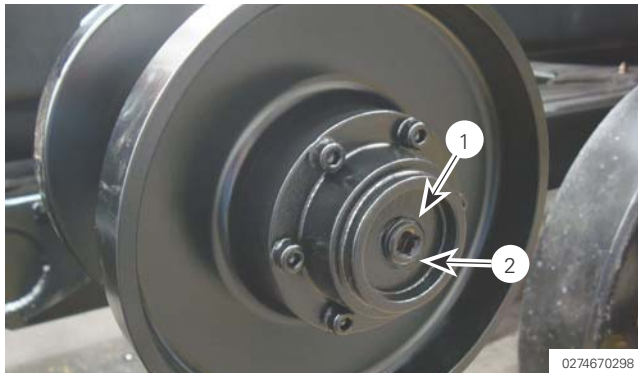

Figure 216

1. Top roller center plug
2. Recommended oil level in the hub

It is required to change the oil in the top roller hubs at regular intervals. To do so, proceed as follows:

- » Install a recipient under the hub to collect used oil.

ENVIRONMENTAL PROTECTION : Dispose of oil according to prevailing legal requirements.

- » Loosen the hub cover (six bolts) and wait until the oil is drained.

NOTE : Removing and positioning the filling plug (item 2 on Figure 217) at 6 o'clock will drain the oil faster.

- » Remove the six bolts and the hub cover.
- » Inspect the cover internal surface and the bearing exposed parts. Replace worn or damaged parts. Remove and clean the magnetic center plug of the hub cover and clean the hub cover.
- » Using a new O'ring, re-install the cover on the hub. Torque attaching bolts to 20 N•m (15 lbf-ft).

- » If required, using suitable beams of wood or equivalent, slightly raise the track over the top roller being serviced.
- » Using the top plug cavity as shown on the following figure, fill the hub to the recommended level with oil. Refer to "TECHNICAL DATA" on page 114 for information on the recommended oil.

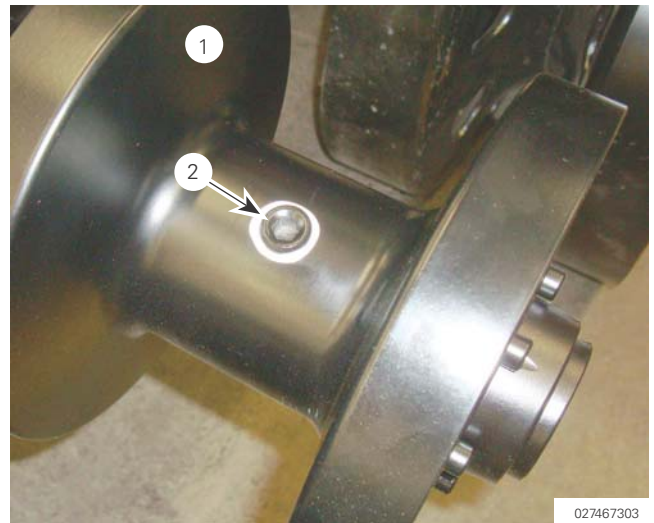

Figure 217

1. Top roller
2. Oil filling plug

- » Re-install the center plug (item 1 on Figure 216) using a sealing compound.
- » Re-install the filling plug (item 2 on Figure 217) using a sealing compound.
- » Remove the support beams. Repeat for the other hub.

DRIVE SYSTEM MAINTENANCE

PARKING BRAKE VERIFICATION

The brake operation has to be verified if brake was applied while the vehicle was in motion. Additionally, verify at every 50 hours of vehicle operation.

Verify if the parking brakes can hold the vehicle. Using caution, perform the following:

- » Secure the vehicle and shutdown the engine.
- » If not already done, set the engine rpm control knob to the minimum and apply the parking brake (with the parking brake button on the dash). Set the transmission lever to neutral and release speed pedal.
- » Position the emergency drive module on a thigh with the strap and set the sliders on the module to the neutral position. Ensure the module switch is "off".
- » Plug the emergency drive module cable into the connector on the lateral console (see Figure 262).

NOTE : On the cable of the emergency drive module, only one of the male connectors will fit with the female connector of the dash. The other connector remains unused.

- » Start the engine.
NOTE : Engine will automatically turn at 1500 rpm.
- » Activate the emergency drive module by pressing the "ON - OFF" button. Leave the brakes applied.

WARNING

Impact and crush hazard

Never perform this brake test with bystanders present. If the brakes slip or fail, the vehicle will move unexpectedly and may cause severe injuries or death to bystanders. Establish a safety perimeter around the vehicle before proceeding with the next step.

- » While taking all necessary precautions, test the brakes by trying to get the vehicle in a forward motion. To do so, push both sliders on the emergency drive module forward and hold for two or three seconds, then return the sliders to neutral.
 - » If the brakes **hold** and the vehicle does not move, the brakes are operational;
 - » If the brakes **do not hold** and the vehicle moves, **do not operate the vehicle**. Perform brake maintenance without delay;
- » Turn off the emergency drive module and disconnect it from the vehicle.
- » Turn off the engine.

TOWING

Tips for towing the vehicle on an uneven terrain

In a situation where the vehicle has lost one track and has to be towed, it is recommended to install a chain on the undercarriage to prevent damage.

NOTICE

The front tandem may flip over and the wheels could damage the accessory support frame if the vehicle is towed over a hole/bump with a missing track. Chain the wheels before proceeding.

If the wheels of front and rear tandems are not chained together (on the side where the track came off), the front tandem may rotate when the vehicle is moved and cause severe damage to several components around the engine.

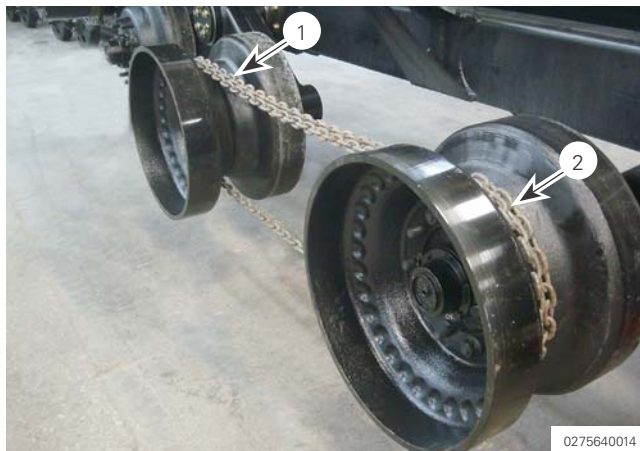

Figure 218

1. Rear wheel of the front tandem
2. Front wheel of the rear tandem

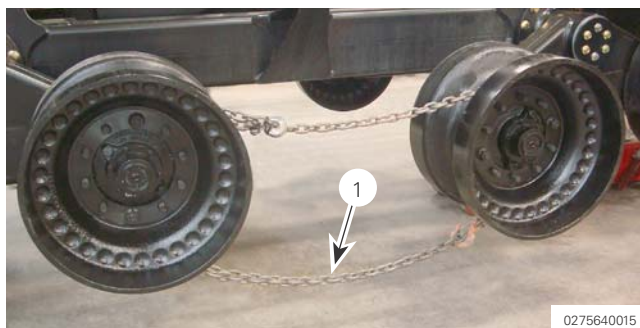

Figure 219

1. Wheels chained together - note the chain tension

Use about 6 m (20 ft) of chain and set the proper tension to prevent the chain from jumping off the wheels but still allow them to turn freely.

Towing Procedure

⚠ WARNING

Impact, pinch and crush hazard
The vehicle loses its braking ability when the planetary gearboxes are disengaged. Ensure that the vehicle is immobilized before proceeding. Failure to do so may cause injury or death.

⚠ WARNING

Accident hazard
Downhill sliding or toboggan effect may occur during towing operation. Proceed carefully and maintain a safe distance. Do not allow operator or passenger in the towed vehicle. Failure to do so may cause injuries or death.

NOTICE

Towing the vehicle without disengaging the planetary gearboxes could permanently damage the drive components.

NOTICE

Never use the “D” rings or a part of the frame to tow the vehicle. Always use the retrieval point.

- » Attach the disabled vehicle to the tow cable or chain using the retrieval point at the rear of the frame;
- » Turn off the ignition switch on the towed vehicle.
- » Disengage both planetary gearboxes on the disabled vehicle. Refer to “Disengaging the Planetary Gearboxes” for instructions.

NOTICE

Damage to the planetary gearboxes may occur if the towing distance is too long. Keep the towing distance as short as possible.
Damage to the planetary gearboxes may occur if the towing speed is too high. Proceed very slowly when towing the vehicle.

- » While choosing the safest and shortest path for towing (no one on board the towed vehicle), slowly set the vehicles in motion.
- » Upon arrival, re-engage each planetary gearbox, **while the vehicle is securely immobilized**, to restore braking ability.

DRIVE SYSTEM MAINTENANCE

NOTE : Towing distance and speed should be kept to the minimum. If towing for a long distance, (not recommended) add new oil to the gearbox housing after the sun and planet gears have been removed.

Disengaging the Planetary Gearboxes

⚠ WARNING

Impact and crush hazard

The vehicle loses its braking ability when the planetary gearboxes are disengaged. Ensure that the vehicle is immobilized before proceeding. Failure to do so may cause injury or death.

The planetary gearbox can be disengaged. Proceed as follows.

- » Ensure that the vehicle is immobilized and secure. Turn off the engine.
- » Clean the area of the disconnect mechanism. Avoid contamination and foreign bodies.
- » Lower the oil level before using the disconnect mechanism.
- » Place a catch basin under the planetary gearbox.

ENVIRONMENTAL PROTECTION : Dispose of oil according to prevailing legal requirements.

- » Remove the 6 hexagon bolts from the center cover.
- » Screw two M6 bolts (approx. 80 mm of length) into the release thread bores of the cover and evenly tighten them to their head support surface. Observe that the cover is not canted. Through evenly tightening the cover is pushed out from the flange.

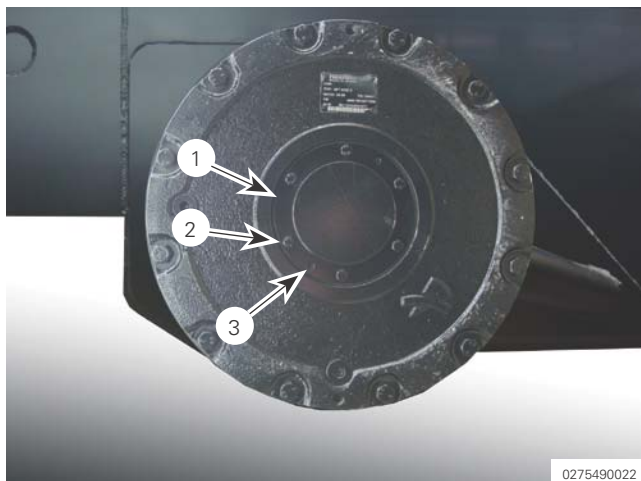

Figure 220

1. Planetary gearbox center cover
2. Center cover bolts
3. Release thread bores (qty 2) of the center cover

- » Remove the cover with the O-ring and the cylinder roll.
- » Remove the two bolts from the center cover.
- » Screw a M8 bolt (approx. 80 mm of length) in the shaft thread center bore of the sun gear.
- » Pull out the sun gear using the temporary M8 bolt.
- » Check the O-ring of the center cover, replace if required.
- » Reinsert the center cover with the O-ring and the cylinder roll on the flange and secure with the 6 hexagon bolts.
- » Readjust the oil level before towing the vehicle.
- » Repeat for the other planetary gearbox. Then the vehicle is ready to be towed.

Re-engaging the Planetary Gearboxes

The planetary gearbox can be re-engaged. Proceed as follows.

- » Clean the area of the disconnect mechanism. Avoid contamination and foreign bodies.
- » Lower the oil level before using the disconnect mechanism.
- » Place a catch basin under the planetary gearbox.
- » Remove the 6 hexagon bolts from the center cover.
- » Screw 2 bolts M6 (approx. 80 mm of length) into the release thread bores of the center cover and evenly tighten them to their head support surface. Observe that the cover is not canted. Through evenly tightening the cover is pushed out from the flange.
- » Remove the cover with the O-ring and the cylinder roll.
- » Remove the two bolts from the cover.
- » Insert the sun gear using (use the temporary M8 bolt if required).
- » Check the O-ring of the center cover, replace if required.
- » Reinsert the center cover with the O-ring and the cylinder roll on the flange and secure with the 6 hexagon bolts.
- » Readjust the oil level.
- » Repeat for the other planetary gearbox.

TRACK TENSION VERIFICATION

Replace worn or damaged track. A damaged track could break during vehicle operation, thus requiring towing or on-site re-tracking.

Ensure the pressure relief buttons are in the running position ("pushed in" position) before returning the vehicle to normal operation. Putting the vehicle in motion with loose tracks could lead to detracking.

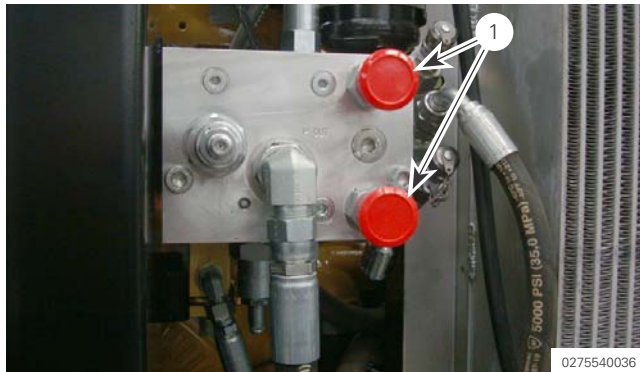

Figure 221

1. Track tension release knob

Track tension adjustment is automatic once the diesel engine is running and the vehicle rides a short distance. To perform a verification of track tension, start the engine and drive at least one vehicle length in straight line on level ground. Then, engage the parking brake but keep the engine running. The upper section of the track should stand horizontal, with little or no sag fore and aft of the top roller (see next figure). While driving, remain vigilant. Ensure track tension is the about the same on both sides of the vehicle.



Figure 222

Correct track tension

WHEEL WEAR VERIFICATION AND WHEEL PERMUTATION

As the vehicle accumulates working hours, the wheels will wear (see next figure) because they rub on the track guides of the track. The rear wheels will wear at a faster rate than the front wheels.

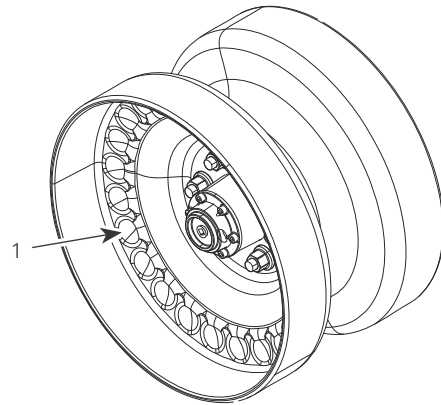

Figure 223

1. One of the wheel wear indicators (circular dot pattern)

The wheels are designed with a dot pattern to give an indication of the degree of wear. Perforation of the wheel wear indicators signifies a worn wheel.

To extend their service life as much as possible, it is recommended to switch wheel position (permute the best wheel with the worst wheel) every 250 hours.

NOTICE

Do not operate the vehicle if the wheel wear is such that perforations can be seen in the dot pattern (wear indicator). A worn wheel will cause permanent damage to the track and to the undercarriage components.

When perforations appear in the dot pattern, the wheel is worn and should NOT exchange position with an other wheel. REPLACE any wheel that is worn or could exceed the wear limit before the next permutation.

Permute the wheels so the best wheels (less worn) are at the back and the worst wheels are at the front. See Figure 224.

NOTE : When performing permutation of the wheels, keep wheel halves together, keep wheels on the same side of the vehicle. It is not required to remove the track to switch the wheels.

DRIVE SYSTEM MAINTENANCE

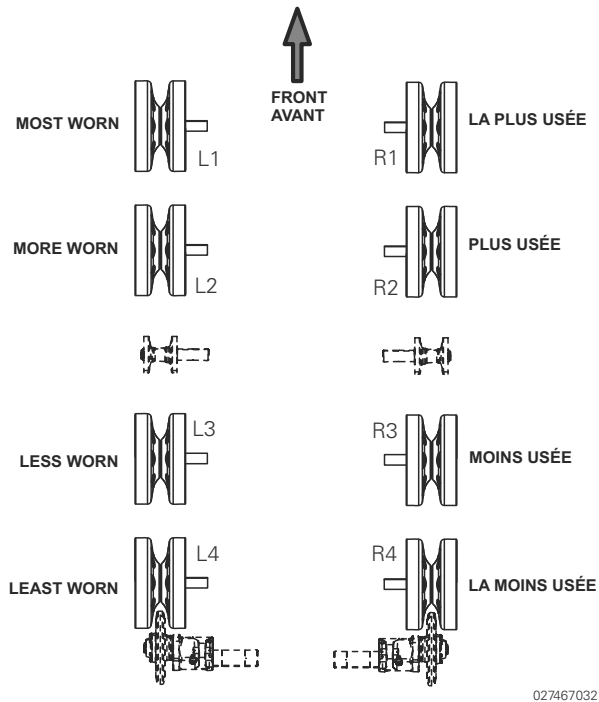
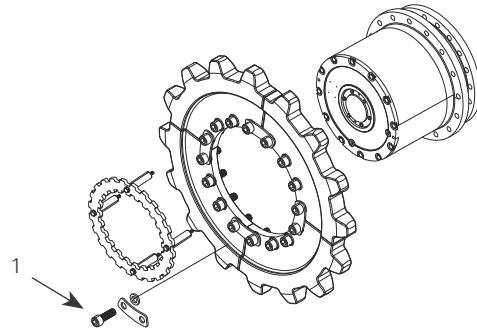

Figure 224
New positions for wheels **after** permutation

VERIFICATION OF THE TORQUE



4119450016

Figure 225

1. Sprocket bolt

Perform a verification of the bolt torque on the left and right sprockets of the vehicle after the first 50 hours of operation. The recommended torque is 705 N•m (520 ft-lb). Repeat the 50 hours verification each time the bolts are reinstalled or replaced.

TIPS FOR TRACK REMOVAL AND INSTALLATION

⚠ WARNING

Pinch and crush hazard

Each track is very heavy and special procedures are required to install or retrieve.

Rotation of a single planetary gearbox or both should be performed with great care.

Always have these tasks performed by two or more trained mechanics to avoid injuries.

The tracks are heavy and should not be manipulated by a single mechanic. Although removal/installation can be accomplished with regular tools by trained personnel, a dedicated piece of equipment is available in the TRACK section of the vehicle parts catalogue.

Removing or installing a track

NOTICE

Turn off the diesel engine if the track tension is released. Leaving the engine running for more than a few minutes could cause permanent damage.

- » Use the track tension release knob to release tension prior to remove/install a track,

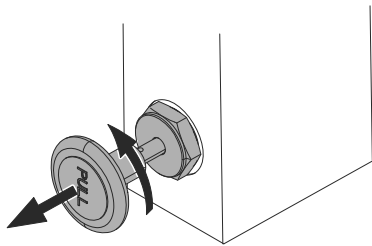

1105340022

Figure 226
Track tension release knob

- » Fully contract the tensioning cylinder. If the cylinder is not fully retracted, moving the track (to or off the vehicle) will be difficult or even impossible.

- » Remove or install exterior wheel halves as required to facilitate the track installation.
- » The track can be removed or install in position once the segments of the sprocket are removed. Each segment can be removed (or installed) after successive partial rotations of the planetary gearbox.

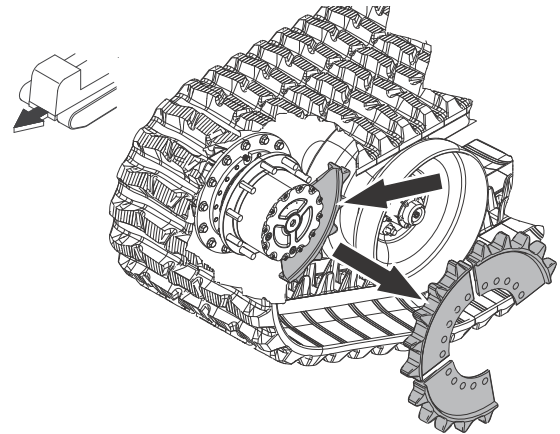

0275230016

Figure 227
Sprocket segments

NOTE : Observing bolt pattern of the sprocket segments prior to removal will facilitate re-installation. Refer to the Prinoth training manual and training course for the complete procedure.

ELECTRIC SYSTEM MAINTENANCE

ELECTRIC SYSTEM MAINTENANCE

⚠ WARNING

Fire hazard

Replacing a fuse with one of higher rating could cause overheating or even fire. Always replace a fuse with one of the same rating.

ACCESSING THE CAB ELECTRICAL BOX



Figure 228

1. Electrical box locking knob



Figure 229

Electrical box components

The cab electrical box contains fuses, breakers and relays.

To open the box cover, rotate the central knob toward the “UNLOCK” indication and pull-out the cover. To close the box cover, install in position, press the central knob and rotate toward the “LOCK” indication.

Always operate the vehicle with the cover installed. There are no spare fuse in the housing.

Improper fuse rating could cause overheating and fire.

A tool (yellow extractor) is provided in the box to extract fuses or breakers from the electrical box.

REPLACING A FUSE IN THE CAB

Refer to the fuse identification sticker inside the cover of the electrical box for information. A repeatedly burning fuse could indicate a problem. Investigate if a fuse has to be replaced more than once in a short period of time.

A tool (yellow extractor) is provided in the box to extract fuses (see next figure).

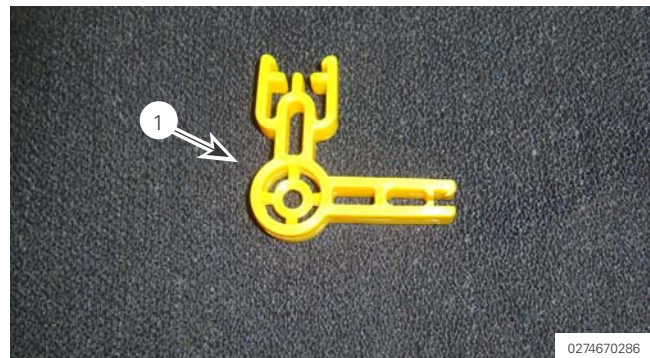
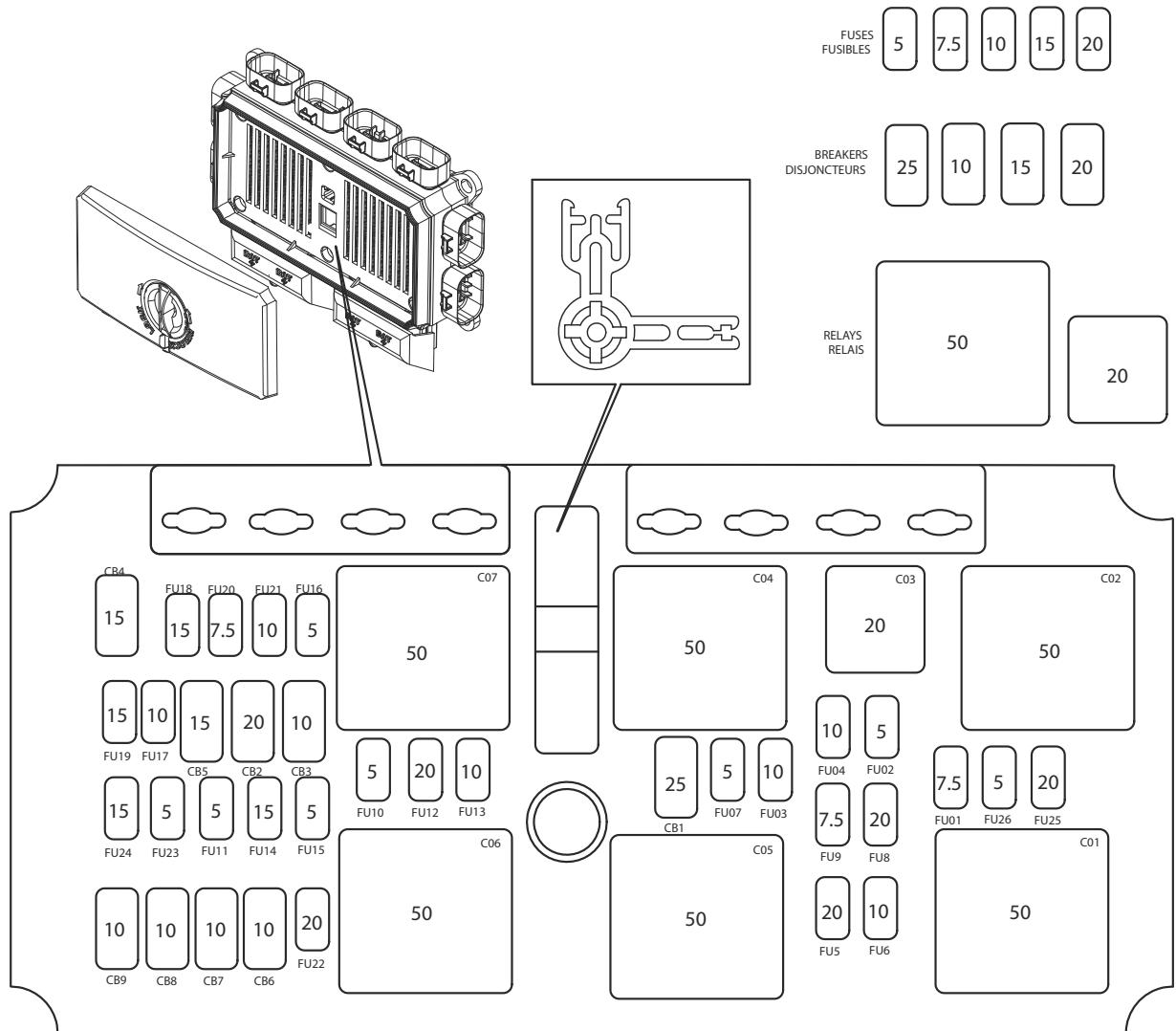

Figure 230

1. Fuse extractor

To change a fuse, proceed as follows:

- » If not already done, turn off the engine, remove the key from the ignition switch;
- » Turn off the battery isolator switch.
- » Remove the cover of the cab electrical box and identify the fuse to replace.
- » Extract the burned fuse and replace with one of an identical type and rating.
- » Re-install the electrical box cover.
- » Turn on the battery isolator switch.
- » Check function of the repaired circuit.



FU01 = MICRO CONTROLLER RELAY / RELAIS MICRO CONTRÔLEUR
 FU02 = BRAKE RELAY / RELAIS FREIN
 FU03 = FLASHER / CLIGNOTANT
 FU04 = TEMPERATURE CONTROL / CONTRÔLE DE TEMPÉRATURE
 FU05 = FUEL HEATER OPTION / OPTION CHAUFFE CARBURANT
 FU06 = HUDRALIC OPTION / OPTION HYDRAULIQUE
 FU07 = ECM ENGINE / ECM MOTEUR
 FU08 = POWER SUPPLY OPTION / OPTION ALIMENTATION
 FU09 = OPTIONAL CONTROLLER / CONTRÔLEUR OPTIONNEL
 FU10 = FREE / LIBRE
 FU11 = WINCH OPTION
 FU12 = 12 VOLTS OUTLET / PRISE 12 VOLTS
 FU13 = RADIO POWER / ALIMENTATION RADIO
 FU14 = SEARCH LIGHT OPTION / OPTION LAMPE DE RECHERCHE
 FU15 = SWITCH LIGHT / LUMIÈRE INTÉRIÈRE
 FU16 = DOME LIGHT / PLAFONNIER
 FU17 = MIRROR DEFROST OPTION / OPTION MIROIR CHAUFFANT
 FU18 = FRONT LIGHT / LUMIÈRE AVANT
 FU19 = FRONT LIGHT OPTION / OPTION LUMIÈRE AVANT
 FU20 = REAR LIGHT / LUMIÈRE ARRIÈRE
 FU21 = BEACON LIGHT / GYROPHARE
 FU22 = PRE-HEATER OPTION / OPTION PRÉ-CHAUFFAGE

FU23 = RADIO MEMORY / MÉMOIRE RADIO
 FU24 = HAZARD LIGHT / FEUX DE DÉTRESSE
 FU25 = 12 VOLTS OUTLET / PRISE 12 VOLTS
 FU26 = IGNITION SWITCH / INTERRUPTEUR DE DÉMARRAGE
 CB01 = CAB HEATER / CHAUFFAGE CABINE
 CB02 = FRONT WIPER HIGHT SPEED / ESSUIE-GLACE HAUTE VITESSE
 CB03 = FRONT WIPER PARKING / ESSUIE-GLACE AVANT POSITION D'ARRÊT
 CB04 = FRONT WIPER LOW SPEED-HORN-WINDSHIELD WASHER / ESSUIE-GLACE AVANT BASSE VITESSE-KLAXON-LAVE-VITRE
 CB05 = REAR WIPER / ESSUIE-GLACE ARRIÈRE
 CB06 = ENGINE ECM / ECM MOTEUR
 CB07 = ENGINE ECM / ECM MOTEUR
 CB08 = ENGINE ECM / ECM MOTEUR
 CB09 = ENGINE ECM / ECM MOTEUR
 C01 = IGNITION RELAY / RELAIS ALLUMAGE
 C02 = MICRO CONTROLLER RELAY / RELAIS MICRO CONTRÔLEUR
 C03 = BRAKE RELAY / RELAIS FREIN
 C04 = AUTO BRAKE RELAY / RELAIS FREIN AUTOMATIQUE
 C05 = IGNITION RELAY / RELAIS ALLUMAGR
 C06 = ACCESSORY RELAY / RELAIS D'ACCÉSSOIRE
 C07 = ACCESSORY RELAY / RELAIS D'ACCÉSSOIRE

0274670150

Figure 231
 Schematic of cab electrical box

ELECTRIC SYSTEM MAINTENANCE

REPLACING THE FUSE OF THE CAB HEATER

The fuse of the cab heater unit is located below the electrical box of the cab.

To change the fuse, proceed as follows:

- » If not already done, turn off the engine, remove the key from the ignition switch;
- » Turn off the battery isolator switch.
- » Remove the cover of the cab electrical box.
- » Remove the two bolts holding the plastic liner. Gently pull out the liner and identify the fuse to replace.



Figure 232

1. Plastic liner around the electrical box
2. Holding screws

- » Extract the burned fuse and replace with one of an identical type and rating.

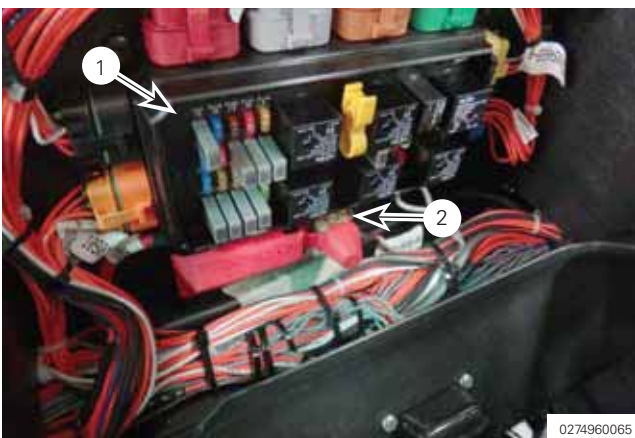

Figure 233

1. Electrical box in the cab
2. Fuse of the cab heater unit

- » Re-install the plastic liner.
- » Re-install the electrical box cover.
- » Turn on the battery isolator switch.
- » Check function of the repaired circuit.

REPLACING A FUSE ON THE BATTERY SUPPORT



Figure 234

1. Starter relay
2. Power distribution module on the battery support

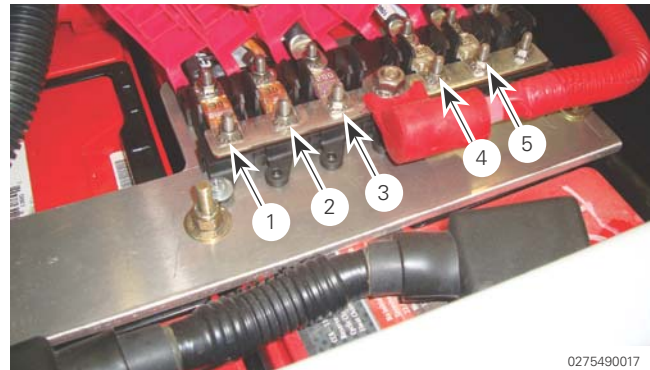

Figure 235

1. PETU fuse (30 A rating)
2. ECM fuse (30 A rating)
3. Cab fuse (200 A rating)
4. Glow plug fuse (80_A rating)
5. Starter fuse (80_A rating)

To change a fuse, proceed as follows:

NOTE : If changing both, replace them one at a time.

CAUTION

Fire hazard

Never invert fuse position. Fuse ratings are very different and cannot be interchanged.

- » If not already done, turn off the engine, remove the key from the ignition switch;
- » Turn off the battery isolator switch. Gain access to the fuse.
- » Raise the protective cap and remove the nuts retaining the fuse to replace. **Work only on one fuse at a time.**
- » Extract the burned fuse and replace with one of an identical type and rating.

- » Re-install the nuts holding the fuse and lower the protective cap in position.

NOTICE

Make sure the fuse holder is protected by a rubber boot in good condition. Unprotected holder could contact a metal conductor and be damaged by a short circuit.

- » Turn on the battery isolator switch.
- » Check function of the repaired circuit.

BATTERY MAINTENANCE

WARNING

Burn and fire hazard

Battery cells contain hydrogen, a highly combustible gas and sulfuric acid, a corrosive fluid. To avoid injuries:

Keep flames and sparks away from the battery.

Prevent contact between battery fluid and skin, eye, clothing and vehicle.

If battery acid comes in contact with the skin or eyes, immediately flush the area with large amount of fresh water, then get medical attention right away.

When working around the batteries, always wear:

- » Safety glasses;
- » Gloves;
- » Protective clothing.

Cleaning the batteries

Keep the batteries, terminals and terminal clamps clean:

- » Clean the terminal studs or posts, if required, loosen the terminals and clean the contact surfaces.
- » Smear the terminal studs with petroleum jelly or an acid-free, non-corrosive grease.
- » Re-tighten the battery terminals if required.

ELECTRIC SYSTEM MAINTENANCE

Changing the batteries

⚠ WARNING

Burn and electric shock hazard

A conducting material coming in contact with positive and negative battery posts simultaneously will become extremely hot and could cause the batteries to explode. Prevent contact between opposite polarity posts. Always wear protective gloves, goggles and clothing before using the lugs. Keep protective covers in place.

- » Turn off the battery isolator switch.
- » Disconnect all the wires from the negative poles of the batteries.
- » Disconnect all the wires from the positive poles of the batteries.
- » Carefully remove the central aluminium battery holder. Ensure the holder does not come in contact with the battery posts.
- » Remove the batteries from the holder.
- » Install the new batteries. Do not mix new batteries with old batteries.
- » Carefully install the central aluminium battery holder. Ensure the holder does not come in contact with the battery posts.
- » Reconnect all the wires to the positive poles of the batteries.
- » Reconnect all the wires to the negative poles of the batteries.
- » Turn on the battery isolator switch.

ELECTRIC COMPONENTS AND WATER



Do not spray water directly on electrical components when washing the vehicle. Cover the following parts to prevent water from getting on them:

- » Instrument panel, fuses, switches, sensors and connectors;
- » Starting motor, alternator, sensors and connectors around the engine;
- » Batteries, relays, fuses.

CAB AND FRAME MAINTENANCE

UPPER STRUCTURE SWINGING SYSTEM

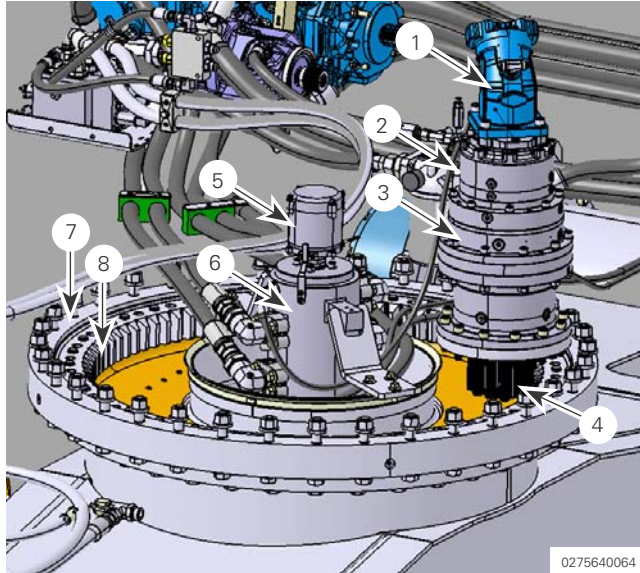

Figure 236

1. Hydraulic motor
2. Brake unit
3. Gearbox unit
4. Pinion
5. Slip ring with integrated position sensor
6. Slip joint
7. Slewing bearing outer race
8. Slewing bearing inner race with gear

Raceway lubrication of the slewing bearing

Raceways must be lubricated at intervals according to the actual operating conditions of the equipment.

NOTICE

Make sure that the grease fittings are clean before connecting the tool and applying grease.

It is recommended to grease the raceway every 50 hours of use. Before and after long periods of idleness, the bearing must be greased again.

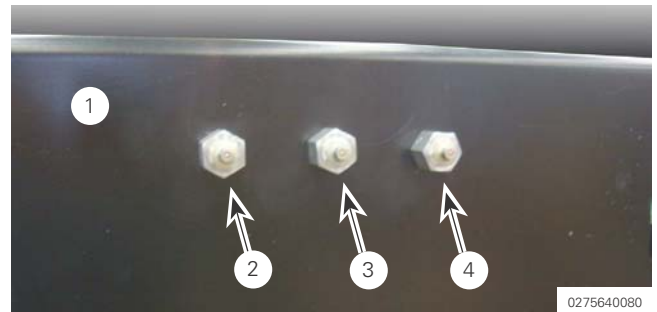

Figure 237

1. Grease fitting location under the rear edge of the dump body
2. Left grease fitting for the dump body cylinder rods
3. Center grease fitting for slewing bearing
4. Right side grease fitting for slewing bearing

NOTE : Two of the three grease fittings under the rear edge of the dump body are connected to hoses that bring the grease to four orifices around the slewing bearing.

To grease the raceway, proceed as follows:

- » Apply grease in each of the two grease fittings, the center one and the right one. See previous figure.
- » Then turn on the engine and perform one complete rotation.
- » Shutdown the engine and repeat the process one more time.

Greasing is considered completed when the grease overflows from the seal forming a light film, which also has a sealing effect.

Raceway standard grease corresponds to : Multi-season, lithium based, NLGI grade 1 EP rated with "MOLY" additives, water resistant, minimum service temperature of -40°C to 100°C (-40°F-212°F) approved for automobile wheel bearing and chassis.

CAB AND FRAME MAINTENANCE

Pinion lubrication

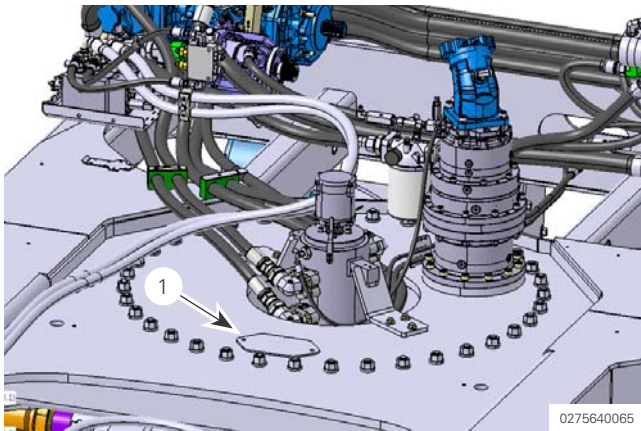

Figure 238

1. Access panel to insert grease sticks for pinion lubrication

The space where the drive pinion engages the teeth of the slewing ring must be lubricated.

It is recommended to grease the pinion cavity every 500 hours of vehicle operation. Before and after long periods of idleness, the pinion must be greased again.

To perform the lubrication, clean the area around the access panel. Open the grease access panel and drop a grease "stick" inside the grease chamber. Reinstall the access panel.

To lubricate the pinion, use the following grease:
Multi-season, lithium based, NLGI grade 1 EP rated with "MOLY" additives, water resistant, minimum service temperature of -40°C to 100°C (-40°F to 212°F) approved for automobile wheel bearing and chassis.

Gearbox and brake oil replacement

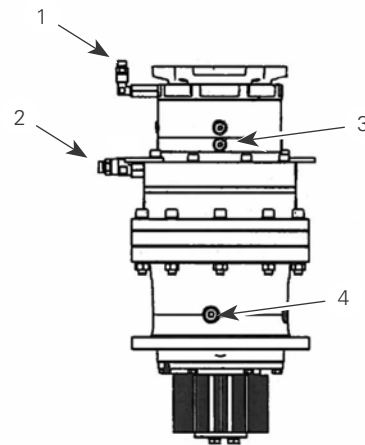

Figure 239

1. Fitting used as a level plug for the brake unit
2. Fitting used as a level plug for the gearbox unit
3. Drain plug for the brake unit
4. Drain plug for the gearbox unit

0275640060

The unit contains oil for the brake (upper section of the unit) and oil for the gearbox (lower section of the unit).

Check the oil levels monthly. Use the hose fittings as level plugs. Verification interval is the same for the brake and for the gearbox.

Change the oil of the brake section and the gearbox section after the first 100 hours. Wash the interior of the unit with a cleaning fluid. Check that there is no metallic parts with unusual dimension in the magnetic plug of the gear unit and in any multi-disk brake. Change the oil in the gear unit while it is hot so that it is easier to drain. Subsequent oil changes are to be made every 2500 hours of operation, or yearly, whichever comes first.

NOTE : If the oil level has risen in the gearbox unit, this could mean a leaking seal of the brake unit or of the hydraulic motor.

When replacing the oils, use the level plugs as indicator of quantities. Refer to "TECHNICAL DATA" on page 114 for information on the recommended oils (brake and gearbox).

Clearance measurement

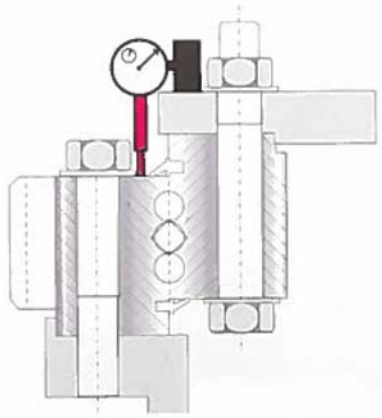

0275640016

Figure 240
Comparator on slewing bearing

The best practice is to perform measurement once a year. Always use the first measurement as a reference to evaluate the wear of the slewing ring raceways and its rolling elements. Normal limit of acceptable wear is 3 times the initial machine clearance.

Ensure the measurement is made under the same conditions each time, otherwise the results are not usable. The vehicle needs to be loaded, the load should be the same, as much as possible, at each measurement.

NOTE : To read the proper clearance value, install a 0.01 mm or 0.001 inch precision comparator close to the slewing bearing, pointing to read vertical clearance.

The comparator needs to be installed on the lifting side of the vehicle, in line with the middle of the upper frame.

Then, perform the following:

1. Adjust the comparator to 0 mm or 0 inch for reference.
2. Slowly lift the rear upper frame until the dial of the comparator stop increasing or the undercarriage starts to move up. Mark this value.
3. Move down and ensure the reference is still at 0 mm. Repeat a second time to ensure the reading is consistent.

4. Repeat all previous steps after rotating the upper frame 90 degrees three times to obtain 4 measures. The comparator has to be reinstalled at each rotation to follow the rear of the upper frame.

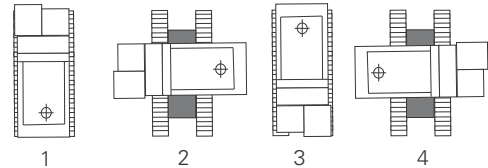

0275640070

Figure 241
Required four positions for the clearance measurement

Lifting the rear of the upper frame

Using a 20-ton floor jack and spacer block, place the lifting point under the center of the rear beam. Stay out of the way when lifting and do not go under the vehicle when reading the value on the comparator.



0275640069

Figure 242
Floor jack and rear of upper frame

CAB AND FRAME MAINTENANCE

Backlash verification

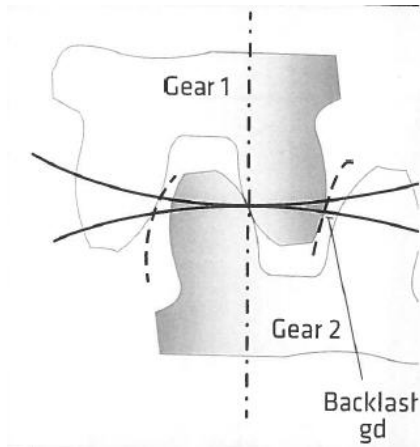

0275640020

Figure 243
Example of a backlash

Backlash of the swing gearbox assembly

Total gearing backlash must be adjusted to obtain an indicative value of 0,47 to 0,90 mm measured at the pitch diameter of the pinion between the input spline and output shaft (including the brake).

Backlash between pinion and slewing gear

Gearing backlash must be adjusted as to obtain an indicative value of 0,5 to 1,0 mm.

Total backlash measurement



0275640063

Figure 244
Backlash measurement location

Total backlash measurement is the swing gearbox assembly backlash plus the pinion/slewing gear backlash.

NOTICE

Make sure that the vehicle is in the normal configuration (cab and cowling above the drive sprockets) to perform the measurement. Any other position will lead to incorrect measures.

The total backlash measurement can be measured on one of the corners of the upper frame at the back (under the rear edge of the dump body).

When taking into consideration the distance between the center of the slewing bearing and one of the rear corner of the upper frame, the acceptable play must be $8,5 \pm 1,5$ mm. Maximum acceptable value is 20 mm.

Install a stepladder as a reference point besides a corner of the rear upper frame (vehicle in normal configuration). With a measuring tape and a helper, measure the total displacement of the upper frame. The helper needs to maintain a good pressure on the frame while the measure is taken.

- » If the measurement is within the indicated values, resume operation normally.
- » If the measurement is outside the indicated value (more than 20 mm), excessive wear is present. Consult the proper documentation and the Prineth Service department to repair the rotating assembly.

CAB STRUCTURAL INTEGRITY / ROPS

WARNING

Crush hazard

Altering the cab structure could reduce its resistance to impacts and cause severe injuries or death in an accident. Do not modify the cab and its attaching hardware in any way.

Do not alter the cab structure, its support hardware or underlying frame in any way as this could reduce its resistance to an impact, a roll over, an object falling or other situation potentially harmful.

Do not drill, weld, cut or bend the cab structure, roof grill or the brush guard. Do not modify or remove the windows or door.

If a window, door, grill or a part of the cab structure is damaged or worn out, replace by a trained mechanic with a genuine PRINOTH part. If a part of the cab support hardware is damaged or worn out, replace with a genuine PRINOTH part.

If the cab structure is damaged, bent or cracked, it should be inspected without delay by a competent authority licensed to issue a new certification for the cab and vehicle. Replace the cab if it fails the inspection. The cab structure includes the cab, its support hardware and the underlying frame.

An annual inspection of the cab is recommended to ensure there are no crack or other damage to the structure of the cab, attaching hardware and windows. Refer to the label in the cab for information on the ROPS.

NOTE : Failure to follow these directions and requirements will invalidate the ROPS and/or FOPS certification.

USING THE THREADED HOLES ON CAB TOP

WARNING

Crushing hazard

Attaching a structure or equipment to the cab could change its weight and resistance to impact, resulting in serious injury or death. Never modify a ROPS cab in any way.

Each corner of the cab top is equipped with a threaded hole. These can be used exclusively to fasten the FOPS grill or lift the cab for maintenance purposes (cab must be empty). Do not attach any other equipment using these holes.

When not in use, leave a bolt in the hole to prevent corrosion.

CHECKING FRAME STRUCTURAL INTEGRITY

An annual inspection of the frame is recommended to ensure there are no crack or damage to the structure as this could compromise safety and performance.

In the same area, verification of the tightness of the bolts and nuts of the frame assembly is recommended. Check at least once a year, more often if type of operation requires it.

PRECAUTIONS AGAINST SALT WATER AND CORROSION

If crossing shallow bodies of salt water or if operating near salt water, thoroughly clean the vehicle at regular intervals to prevent corrosion.

WELDING

Welding on the vehicle is not recommended.

Welding can produce high voltage which could cause damage to the vehicle electronic components. Additionally, welding could affect the cab (or frame) structural integrity. Always obtain the permission of a PRINOTH Service Representative before performing any welding on the vehicle.

If welding is performed on accessories attached to the vehicle, turn off the battery isolator switch AND disconnect the batteries.

RELEASING HYDRAULIC PRESSURE

To release pressure before maintenance, perform the following:

Hydrostatic reservoir

- » Turn off the diesel engine;
- » Open the pressure cap of the hydrostatic reservoir (cap may be hot);
- » Re-install the pressure cap;
- » If working on a cylinder or hose, ensure there is no load applied to it before opening the circuit. See the next two sub-sections.

Dump body hydraulic circuit

- » Start the diesel engine;
- » Raise the dump body;
- » Install the safety rod;
- » Turn off the diesel engine;
- » Push forward the joystick and hold for one minute.

Track tensioner hydraulic circuit

- » Turn off the diesel engine;
- » Open cowling side access panel;
- » Pull out and turn 90° the track tension release knob.

CAB AND FRAME MAINTENANCE

REPLACEMENT OF HOSES AND FITTINGS

Follow all best maintenance practices when performing inspection, installation or maintenance of hydraulic hoses and fittings. Discard all worn or damaged hydraulic hoses and fittings. Some fittings cannot be re-used, ensure they are replaced with genuine new Prinoth parts.

CONNECTING AND DISCONNECTING HYDRAULIC HOSES

This section applies to hoses with quick connect couplings only.

⚠ WARNING

High pressure oil
Oil escaping under pressure can penetrate skin and cause severe injuries. Release pressure and use protective clothing or equipment before servicing the hydraulic/hydrostatic system.

Prior to connection, release pressure as described in "Releasing Hydraulic Pressure", wear protective glasses and clothing, always check for leaks with a piece of cardboard.

ENVIRONMENTAL PROTECTION : Work in a way to prevent oil losses and spills. Dispose of oil soaked material in an environmentally safe manner.

All types of circuits:

Always turn off the engine before proceeding. Ensure all fittings are clean before connecting to a circuit. Use a cap to protect fittings from damage and dirt.

Hydrostatic circuits:

When connecting hoses with quick connect couplers, always connect the drain hose **first**. When disconnecting hoses, always disconnect the drain hose **last**.

REPLACING LIGHT BULBS

General Precautions

- » Do not look directly into the beam of light, the bulb emits UV light which may cause eye damage.
- » Always turn off the lights before replacing bulbs.
- » Ensure the bulb has cooled down.
- » Do not turn on the lights if no bulb is present in the light.
- » Do not touch the bulb with bare fingers as this could reduce its life expectancy.
- » Ensure every bulb is replaced with one of the same type and rating.

⚠ CAUTION

Burn hazard
Powered halogen lights become very hot. When replacing bulbs, always wear safety goggles and protective gloves.

Cut hazard
Halogen lights are under high pressure. If a bulb burst in an enclosed space, leave the area and allow to ventilate for at least 20 minutes as escaped gases are harmful.

ENVIRONMENTAL PROTECTION : Do not dispose of light bulbs in household waste.

Orange position/flasher lights

The light bulbs of the parking lights cannot be replaced. For the parking lights, replace the hole unit.

Proceed as follows:

- » By pressing on the short edge with fingers, carefully push the unit inside the cab body;



Figure 245

- » Turn it 90 degrees and pull it out of the body;

- » Disconnect the electrical cable and discard the light unit;
- » Remove the rubber boot and install it on the new light;



Figure 246

- » Connect the new light unit to the connector;
- » Re-install the unit. Ensure the rubber boot is well seated.

Beacon light

The light bulb of the beacon light can be replaced.

Proceed as follows:

- » Gently press and hold the lens release button;
- » Rotate the prism lens and pull up to remove it;

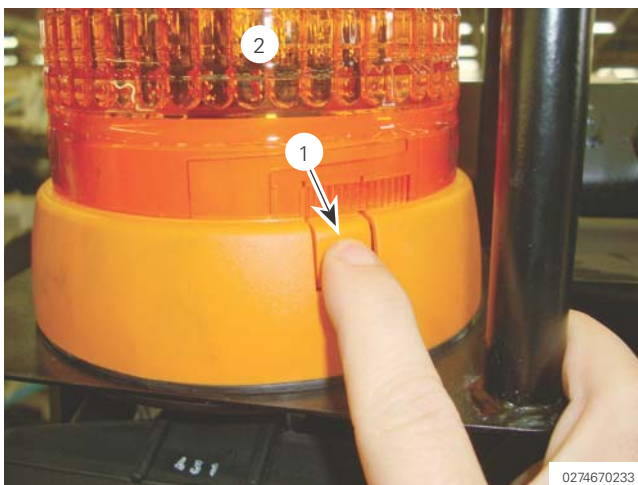

Figure 247

1. Lens release button
2. Prism lens



Figure 248

1. Bulb

- » Pull out the burned bulb;
- » When installing a new bulb, use gloves or a piece of cloth. Do not touch the bulb with the fingers as this will shorten the service life of the bulb.
- » Ensure the reflector is clean. Do not use chemicals to remove spots.
- » Re-install the prism lens.

Front and rear working lights

The light bulb of the front beams can be replaced. Proceed as follows:

- » Remove the front section of the housing;



Figure 249

- » Squeeze the bulb holding wires;

CAB AND FRAME MAINTENANCE



Figure 250

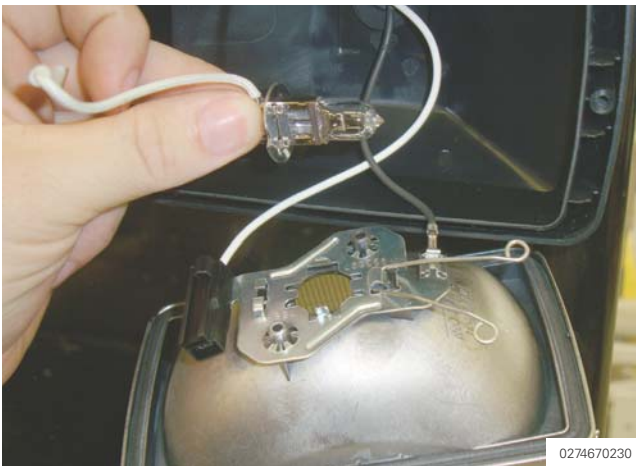

Figure 251

- » Pull out the burned bulb;
- » Using gloves or a soft cloth, install the new bulb in position;
- » Re-position the holding wires and re-install the front part of the housing.

Directional light

The light bulbs of the directional light can be replaced. Proceed as follows:

- » Remove the front section of the housing;



Figure 252

- » Disconnect the electrical connector from the bulb holder.

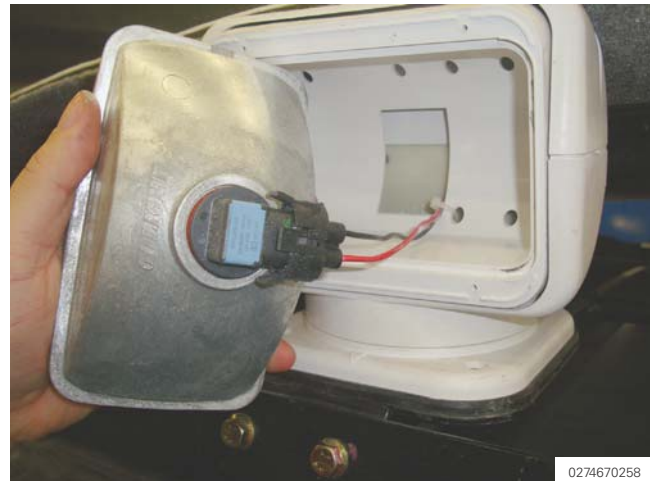

Figure 253

- » Rotate the bulb holder a third of a turn and gently pull out the bulb;



Figure 254

- » Pull out the burned bulb;
- » Using gloves or a soft cloth, install the new bulb in its holder;
- » Re-connect the electrical cable:
- » Re-position the holder in the housing and re-install the front part of the housing.

REPLACING THE CAB AIR FILTERS

One of the cab air filters is located outside the cab, forward of the exterior door latch. The other filter is located inside the cab, behind the seat. Inspect the filters at regular intervals and clean or replace as required.

Exterior Filter

To replace the exterior filter, remove the bolts holding the air filter cover. Remove the existing filter and replace with a new one. Re-install the cover.



Figure 255

Exterior cab air filter location

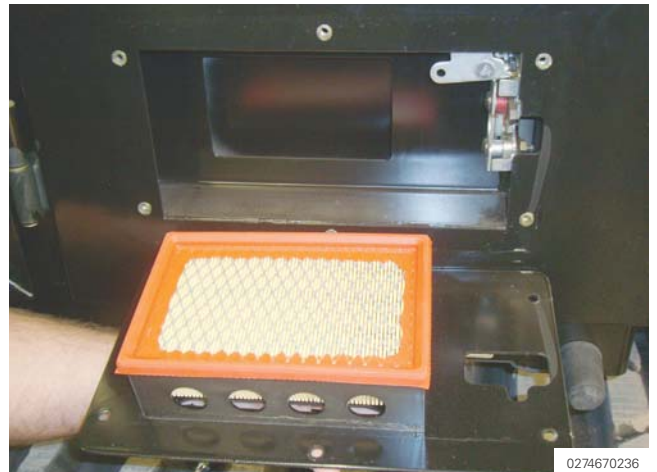

Figure 256

Exterior cab air filter

CAB AND FRAME MAINTENANCE

Interior Filter

To replace the interior filter, pull-out the existing filter and insert the new filter in position.

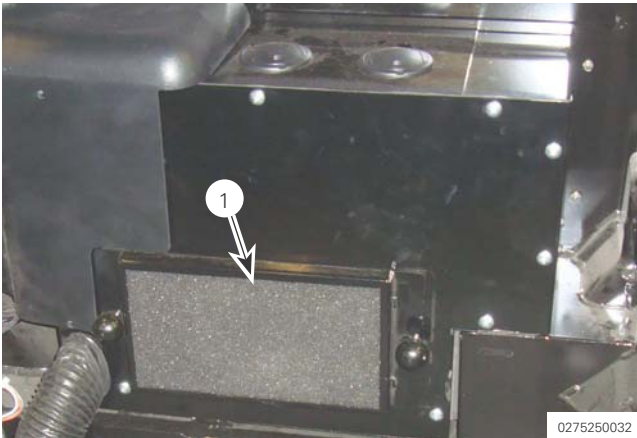

Figure 257

1. Interior cab air filter location

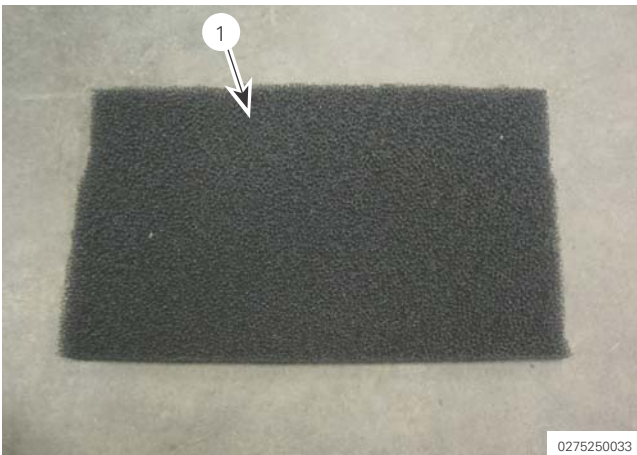

Figure 258

1. Foam air filter inside the cab

Air conditioning and ventilation efficiency can be adversely affected if the filters are clogged.

FRONT AND REAR WIPER INSPECTION

Inspect the front and rear rubber wiper blades and general wiper assemblies. Replace worn blade if assembly is in good condition. Replace the complete unit if damage is detected.

To replace the front or rear wiper use a screwdriver. Remove the holding screw, replace the wiper and re-install the holding screw.

CHANGING A WIPER BLADE



Figure 259

Front wiper blade

NOTICE

Worn wiper blades could produce permanent marks on the windshield. Inspect blades regularly and replace as required.

Keep the wipers in good condition to improve visibility in bad weather.

MISCELLANEOUS MAINTENANCE

USING THE EMERGENCY DRIVE MODULE

In the event of an emergency involving the failure of the steering wheel potentiometer, the transmission selector, the speed pedal potentiometer or the micro-controller, the emergency drive module can be used. **This module must only be used for an emergency return to base. Do not use it under any other circumstance.**

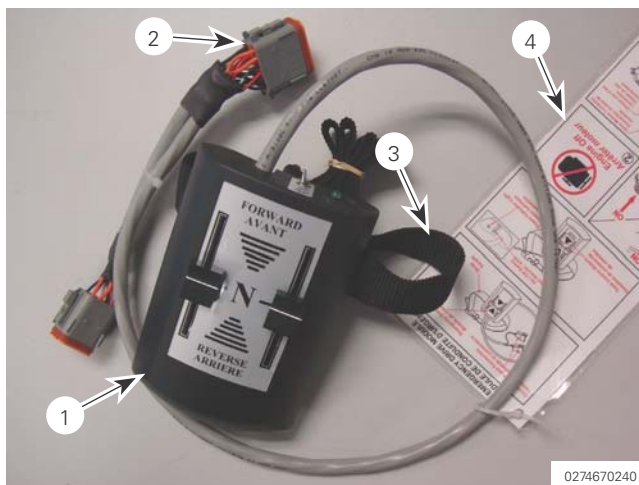

Figure 260

1. Emergency drive module
2. Connector (the larger one is used on the PANTHER)
3. Thigh strap
4. Quick reference card

⚠ WARNING

Accident hazard

The emergency drive module does not provide the same precision as the steering wheel. The operator could lose control of the vehicle which may result in severe injuries or death.

Read and understand the following installation and operation procedures before using the emergency drive module. Proceed slowly with utmost care and caution on return trip to base.

On arrival, secure the vehicle. Then, remove the emergency drive module and repair the vehicle drive system as soon as possible.

NOTE : When using the emergency drive module, the maximum speed of the vehicle is slightly reduced and the anti-stall feature is disabled. Additionally, the LCD display will show fewer information since the microcontroller is disabled while the module is in operation.

Installation and Operation

When experiencing problems with the vehicle, proceed as follows with the emergency drive module:

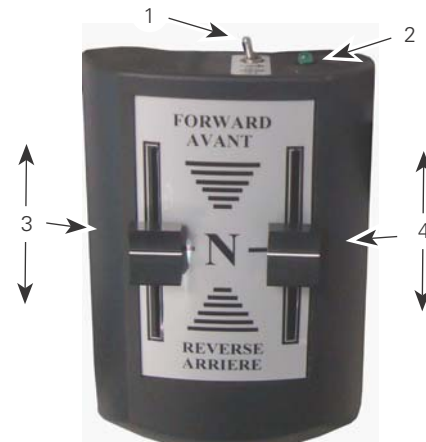

0274670241

Figure 261

1. On/off switch
2. On/off indicator light
3. Left slider (left track control)
4. Right slider (right track control)

1. Secure the vehicle and shutdown the engine.
2. If not already done, set the sliders on the emergency drive module to the neutral position. Ensure the module power switch is "off".
3. Connect the cable of the module to the connector on the lateral console.

NOTE : On the cable of the emergency drive module, only one of the male connectors will fit with the female connector on the dash. The other male connector remains unused.

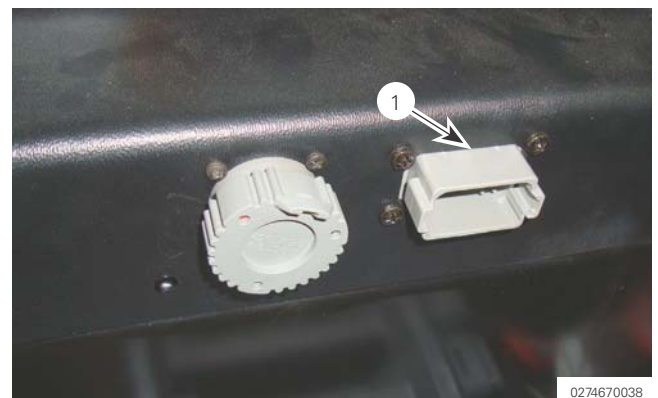

0274670038

Figure 262

1. Emergency drive module connector

MISCELLANEOUS MAINTENANCE

4. Install the module on a thigh with the strap.
5. Start the engine.

NOTE : When the emergency module is connected, upon starting, the engine will automatically run at the preset speed of 1500 rpm and remain there.

6. Activate emergency drive module by pressing the "ON/OFF" button.
7. Disengage the brake.

NOTE : If the sliders are not in the Neutral position when the module is turned on, the vehicle will not move. To set the vehicle in motion, return both sliders to Neutral, then move them slowly to drive the vehicle.

Upon arrival, perform the following:

1. Perform a complete stop of the vehicle by setting the sliders to the neutral position.
2. Apply the parking brake.
3. Turn the engine speed control knob to the minimum.
4. Turn off and disconnect the emergency drive module.
5. Stop the engine by turning the key in the ignition switch to the "off" position.

Investigate the problem and repair the vehicle drive system at once.

WARNING

Accident hazard

If the vehicle is in the inverted configuration, the controls of the emergency drive module will be inverted. Pushing the sliders forward will set the vehicle in reverse and vice versa.

An unexpected motion could lead to an accident. Ensure no one is near the vehicle.

8. Hold the module firmly with both hands and carefully drive the vehicle with the sliders. **The left slider controls the left track, the right slider controls the right track.** Return the vehicle to base by the shortest route.

NOTE : When driving with the emergency drive module, the steering wheel, the transmission lever, the engine speed knob and the speed pedal are no longer functioning.

DUMP BODY MAINTENANCE AND INSPECTION

WARNING

Crush hazard

If the dump body is not secured with the safety rod, a mechanical failure could lower the dump body and cause severe injuries or death. Always secure the dump body with the safety rod before working under it.

An annual inspection of the dump body is recommended to ensure there are no crack or damage to the structure as this could compromise safety and performance. Check more often if type of operation requires it.

In the same area, verification of the pivot assembly is recommended. Verify also the moving cylinders.

WARNING

Crush hazard

Altering the dump body structure could cause structural failure and provoke severe injuries or death. Do not modify the dump body in any way.

Do not alter the dump body structure in any way as this could reduce its resistance to an impact or other situation potentially harmful.

Do not drill, weld, cut or bend the structure. Do not modify or remove parts.

AIR CONDITIONING MAINTENANCE

Air conditioning maintenance must be performed by a trained and certified technician.

CAUTION

Eye, nose and throat irritation hazard

Avoid breathing A/C refrigerant and lubricant vapour or mist. Exposure may irritate eye, nose and throat.

If accidental system discharge occurs, ventilate work area before resuming service.

This system is under pressure and should be serviced by qualified personnel only. Improper servicing could cause injury.

Take all necessary precautions before performing maintenance on this system.

MISCELLANEOUS MAINTENANCE

LUBRICATION

The use of a manual grease gun is recommended. Powered lubrication tools provide less precision and could even damage components if grease is pumped with too much pressure.

Dump body hinges and cylinders

Total: 5 grease points



Figure 263

Lubrication point of the dump body cylinder upper hands (one fitting for both cylinder hands)



Figure 264

Lubrication point of the dump body cylinder lower hand (one left, one right)



Figure 265

Lubrication points of the dump body hinges (one left, one right)

Slewing bearing (swing system)

Total: 2 grease points

Refer to "Upper Structure Swinging system" for the procedure to lubricate the slewing bearing.



Figure 266

Lubrication points of the vehicle slewing bearing

BASIC TROUBLESHOOTING

Refer to the following checklist to solve common problems often not related to failures but on incorrect operation procedure:

The engine will not crank

- » Emergency stop switch/parking brake is not engaged;
- » Batteries are discharged;
- » Battery isolator switch is in the OFF position;
- » Fuse or relay is missing or blown.

The engine cranks but will not start

- » Batteries are weak;
- » Fuel tank is empty;
- » DEF/AdBlue® tank is empty;
- » Air in fuel lines;
- » Lack of starting aid in cold temperature (or glow plugs are still operating);
- » Fuse of engine ECM is blown or missing.
- » Severe fault of aftertreatment/DEF/AdBlue® system.
- » Outside temperature is outside the operating range.

The engine runs but vehicle will not move

- » Brake is engaged;
- » Diesel engine RPM is too low (veh. will not move if engine is below 1000 rpm);
- » Transmission is still in neutral;
- » Transmission was not in neutral when engine was started;
- » Speed pedal is not pressed;
- » Speed pedal was not released when transmission was moved out of neutral;
- » Safety belt on driver's seat is not buckled;
- » Vehicle is overloaded;
- » Tracks are not under tension, vehicle is not tracked, tracks are damaged, foreign objects in tracks;
- » Planetaries are disengaged;
- » Brake valve is disconnected;
- » Left armrest is still in the raised position.

Track will not tension upon engine start

- » Hydraulic track tensioner button is disengaged;
- » Plugs on tensioning cylinders are not installed.

Hydraulic oil overheat

- » Operation above permitted temperature;
- » Track tension is released while diesel engine runs;
- » Air circulation around oil cooler is impaired.

Hydraulic oil cooling fan operates at full speed continuously

- » Operation above permitted temperature;
- » Air circulation around oil cooler is impaired;
- » Emergency drive module is plugged in its connector;
- » Failure of oil temperature sensor;
- » Defective hydraulic valve.

Dump body will not operate

- » The left armrest is raised;
- » The joystick ON/OFF switch is OFF (lock function is engaged);
- » The emergency/parking brake button is engaged.
- » The seat belt is not fastened.
- » The diesel engine is not running.
- » Dump body is overloaded;
- » Safety rod is installed and dump body will not lower;
- » Foreign object between dump body and frame.

The upper frame will not swing

- » The left armrest is raised;
- » The joystick ON/OFF switch is OFF (lock function is engaged);
- » The emergency/parking brake button is engaged;
- » The seat belt is not fastened;
- » The diesel engine is not running;
- » Ambient temperature is lower than the operating range of the system;
- » The vehicle is on a slope steeper than the operating range;
- » The vehicle is not on level ground and heavily loaded;
- » The vehicle is overloaded.

MISCELLANEOUS MAINTENANCE

Enginedrive system power is reduced, engine turns at fixed rpm

- » Engine air filter is severely clogged;
- » Emergency drive module is plugged in the vehicle connector;
- » Vehicle operates in “Limp Home” mode because of a component failure;
- » Vehicle operates in “Limp Home” mode because of high hydraulic oil temperature;
- » Dump body is not completely lowered (veh. equipped with a dump body position detector, the buzzer sounds);
- » Failure of engine RPM control knob;
- » Low DEF/AdBlue® level, contaminated DEF/AdBlue® or problem on the aftertreatment unit;
- » Engine runs on RPM preset;

Engine shutdown (controlled shutdown by software)

NOTE : Due to changes in emissions legislation (Tier 4) some emissions critical diagnostics have non-configurable engine response.

- » Engine fault/failure;
- » Aftertreatment fault/failure;

Fault cannot be erased on LCD display



- » Safety belt is not fastened;
- » Sequence to erase fault is not complete
 - » brake not applied,
 - » armrest not raised,
 - » engine not stopped,
 - » buttons on display not pressed in sequence,
 - » etc.);
- » Source problem not solved.

Radio will not operate or receive a station

- » Radio is not set for country or region;
- » Ignition key is not on “accessory” or “run” on ignition switch;
- » Antenna is damaged or disconnected;
- » Battery isolator switch is set to OFF;
- » Station memory loss.

FASTENER TORQUE CHART

The following chart provides a general guideline on the torque to apply to the bolts and nuts on the vehicle. Refer to the Maintenance/training manual for specific torque applicable to specific bolt/nut.

Dimension Size	Classe 5 		Grade 5		Classe 8 		Grade 8		
	Lube	Dry	Lube	Dry	Lube	Dry	Lube	Dry	
	lb-po (in-lb)		Nm		lb-po (in-lb)		Nm		
Gros / Coarse Filets impériaux / Imperial threads	1/4 x 20	75	100	8	11	105	145	12	16
		lb-pi (ft-lb)		Nm		lb-pi (ft-lb)		Nm	
	5/16 x 18	13	17	17	23	18	25	24	32
	3/8 x 16	23	31	31	40	33	45	45	60
	7/16 x 14	35	50	50	65	50	70	70	90
	1/2 x 13	55	75	75	100	80	105	105	140
	9/16 x 12	80	110	110	145	115	155	150	200
	5/8 x 11	115	150	150	200	160	210	210	280
	3/4 x 10	200	270	260	350	280	380	370	500
	7/8 x 9	320	430	430	570	450	610	600	800
1 x 8	480	640	640	850	680	910	900	1200	
Fin / Fine		lb-po (in-lb)		Nm		lb-po (in-lb)		Nm	
	1/4 x 28	85	115	10	13	125	165	14	18
		lb-pi (ft-lb)		Nm		lb-pi (ft-lb)		Nm	
	5/16 x 24	14	19	19	25	20	27	27	35
	3/8 x 24	26	35	35	45	35	50	50	65
	7/16 x 20	65	90	85	115	95	125	125	165
	1/2 x 20	65	85	85	110	90	120	120	160
	9/16 x 18	90	120	120	160	130	170	170	230
	5/8 x 18	130	170	170	220	180	240	240	320
	3/4 x 16	220	300	290	390	310	420	420	550
7/8 x 14	350	470	470	620	500	670	660	880	
1 x 12	530	700	700	930	750	990	980	1310	

Les valeurs du tableau sont nominales et pour des filets plaqués zinc. La tolérance est de $\pm 10\%$.

The table values are nominal and for zinc plated threads. The tolerance is $\pm 10\%$.

Utiliser la valeur de gauche si le filet est lubrifié (Loctite, huile, etc.) et celle de droite s'il est sec.

Use the left value if the thread is lubricated (Loctite, oil, etc.) and the right if it is dry.

Pour vérification, utiliser un couple équivalent à 90% de celui utilisé pour l'assemblage.

For verification, use a torque equivalent to 90% of the one used for the assembly.

MISCELLANEOUS MAINTENANCE

Dimension Size	Classe 8,8 / Grade 8,8				Classe 10,9 / Grade 10,9				Classe 12,9 / Grade 12,9				
	Lube	Dry	Lube	Dry	Lube	Dry	Lube	Dry	Lube	Dry	Lube	Dry	
	lb-po (in-lb)		Nm		lb-po		Nm		lb-po (in-lb)		Nm		
Gros / Coarse	M5 x 0.8	40	55	5	6	60	80	7	9	70	90	8	10
	M6 x 1	70	95	8	11	100	130	11	15	115	155	13	18
		lb-pi (ft-lb)		Nm		lb-pi (ft-lb)		Nm		lb-pi (ft-lb)		Nm	
	M8 x 1.25	15	19	20	26	20	27	27	35	23	31	32	45
	M10 x 1.5	29	40	40	50	40	55	55	70	45	60	65	85
	M12 x 1.75	50	65	70	90	70	95	95	125	80	110	110	145
	M14 x 2	80	105	110	145	110	145	150	200	130	170	175	230
	M16 x 2	125	165	170	230	170	230	230	310	200	270	270	370
	M18 x 2.5	170	230	230	310	240	320	320	430	280	370	380	500
	M20 x 2.5	240	320	330	440	340	450	460	610	390	520	530	710
M22 x 2.5	330	440	450	600	460	610	620	830	530	710	730	970	
M24 x 3	420	560	570	760	580	780	790	1050	680	910	920	1230	
Fin / Fine		lb-pi (ft-lb)		Nm		lb-pi (ft-lb)		Nm		lb-pi (ft-lb)		Nm	
	M8 x 1	16	21	21	28	22	29	29	40	25	34	34	45
	M10 x 1.25	30	40	40	55	40	55	55	75	50	65	65	90
	M12 x 1.25	55	75	75	100	75	100	105	140	90	120	120	160
	M14 x 1.5	85	115	120	160	120	160	165	220	140	185	190	250
	M16 x 1.5	135	175	180	240	185	240	250	330	210	290	290	390
	M18 x 1.5	195	260	260	350	270	360	360	480	310	420	420	570
	M20 x 1.5	270	360	370	490	370	500	510	680	440	580	590	790
	M22 x 1.5	360	480	490	660	500	670	680	910	590	780	800	1070
M24 x 2	460	610	620	830	630	840	860	1150	740	990	1010	1340	

Les valeurs du tableau sont nominales et pour des filets plaqués zinc. La tolérance est de $\pm 10\%$.

The table values are nominal and for zinc plated threads. The tolerance is $\pm 10\%$.

Utiliser la valeur de gauche si le filet est lubrifié (**Loctite**, huile, etc.), et celle de droite s'il est sec.

Use the left value if the thread is lubricated (**Loctite**, oil, etc.), and the right if it is dry.

Pour **vérification**, utiliser un couple équivalent à **90%** de celui utilisé pour l'assemblage.

For **verification**, use a torque equivalent to **90%** of the one used for the assembly.

MISCELLANEOUS MAINTENANCE

DAILY AND WEEKLY OPERATOR VERIFICATION SCHEDULE

The tasks listed in the next table can be accomplished by the operator.

BEFORE ENGINE START

SYSTEM	TASK WITH ENGINE OFF	DAILY	Every 50 hours
TRACKS	Check condition and wear (check wear indicators)	•	
WHEELS, SPROCKETS & TENSIONERS	Grease track tensioner axles at grease fittings (release track tension before)		•
	Check sprockets, wheels, idler wheels and top rollers for wear or damage	•	
	Check oil level in wheel hubs, idler wheel hubs and top roller hubs		•
	Check the bolt torque of sprockets. Re-tighten if required		•
FUEL	Drain water accumulated in fuel filter/water separator	•	
PLANETARY GEARBOXES	Check oil level		•
ENGINE	Check engine oil level	•	
COOLING	Check engine coolant level, check radiators and oil cooler for leaks	•	
	Check engine radiator, oil cooler and grills for dirt and debris. Clean if required.	•	
PUMP DRIVE	Check oil level		•
HYDRAULIC & HYDROSTATIC	Check oil level	•	
CAB, COWLING, DUMP BODY, SLEWING BEARING and FRAME	Perform a visual inspection of cab & frame	•	
	Check level of windshield washer fluid	•	
	Check if access panels are secure	•	
	Lubricate all grease points		•
	Check presence of the escape tool, fire extinguisher, first aid kit and emergency drive module in the cab. Ensure they are in operating condition. Ensure the safety rod of the dump body is in its stowing position.	•	

AFTER ENGINE START

SYSTEM	TASK WITH ENGINE RUNNING	DAILY	Every 50 hours
BRAKES	Check parking/emergency brake button operation (check icon on display when applying brake)	•	
FUEL	Check fuel level on LCD display main screen, refuel if required	•	
DEF/AdBlue®	Check DEF/AdBlue® level on LCD display main screen, refill if required	•	
OTHER	Check LCD display for warning messages or other indications. Check backup alarm.	•	

MISCELLANEOUS MAINTENANCE

SEVERE SERVICE APPLICATION

An engine that operates outside of normal conditions is operating in a severe service application.

In severe service application, an engine may need more frequent maintenance in order to maximize reliability and service life.

It is impossible to list all conceivable conditions that may lead to severe service application but most fall in the following categories:

- » severe environmental factors (such as altitude, high ambient temperatures, dirty air, etc.);
- » severe operating conditions (such as frequent cold starts, low quality fuel, hot shut downs, etc.);
- » improper maintenance procedure (for examples improper parts, using fluids not recommended, extending maintenance intervals, etc.).

Contact your Prinoth representative for information on how to modify maintenance practices to minimize the impacts of these elements.

ENGINE OPERATING HOURS

The hourmeter, which shows the operating hours on the LCD display, is activated when the ignition key is in the "Run" position.

A small rectangular LCD display showing the number '00h' in a digital font.

The maintenance schedule is based on the number of hours logged by the engine ECM.

MISCELLANEOUS MAINTENANCE

MAINTENANCE SCHEDULE

The tasks listed in the next table can be accomplished by an experienced mechanic or technician.

SYSTEM	TASK	First 50 hrs	Every 250 hrs	Every 500 hrs	Yearly
PLANETARY GEAR-BOXES	Change oil	•		•	•
WHEELS, IDLERS & SPROCKETS	Change oil in wheel hubs, idler wheel hubs and top roller hubs.	•		•	•
	Check torque on wheel and sprocket retaining bolts/nuts. Re-apply torque if required. Repeat if wheel or sprocket is replaced.	•			•
	Check wheel wear. Switch wheel position as recommended.		•		
PUMP DRIVE	Change oil	•		•	
BRAKE	Check parking brake operation (using emergency drive module)		•		
FUEL (Tier 4 engine)	Change filter cartridge in fuel filter/water separator			•	
	Change filter cartridge in the secondary fuel filter			•	
	Change in-line filter			•	
COOLING	Change engine coolant				•
	Check hydrostatic oil cooling system	•			•
	Check engine air and coolant radiators	•			•
ENGINE	Change engine oil and filter			•	•
	Change fuel filters (also in-line filter) primary and secondary	See Fuel above			
	Change air filters	As required			
	Change crankcase breather filter	Every 1500 hours			
	Change PETU filter	As per CAT user manual			
	Check intake and exhaust systems	As per engine manufacturer specifications			
	Check drive belt for wear, replace if required	•			•
	Check condition of rubber and bolt torque on engine support brackets. Check general conditions of engine accessories	•			•
	Check intake and exhaust valve clearance, adjust if required	As per engine manufacturer specifications			

MISCELLANEOUS MAINTENANCE

SYSTEM	TASK	First 50 hrs	Every 250 hrs	Every 500 hrs	Yearly
HYDRAULIC & HYDRO-STATIC	Change oil				•
	Change hydraulic oil filter cartridge when indicated by the gauge or as follows, whichever comes first	•			•
	Change filter cartridge in hydrostatic oil tank (after, perform hyd. system startup if required)	•			•
	Check condition of hoses and check routing	•			•
	Check hydrostatic system for leaks. Check pressure cap.	•	•		
ELECTRICAL	Check condition of batteries	•			•
	Check condition of wiring harnesses	•			•
SWING SYSTEM	Change the oil of the gearbox and brake	First 100 hrs, then yearly			
	Check the backlash of the slewing bearing				•
	Check the clearance of the slewing bearing				•
	Check pinion grease level. Add grease if required	•		•	
CAB & FRAME	Check cab and frame condition	•			•
	Check door adjustment	•			•
	Check fiberglass bushing wear in tandem and crank arm. Replace if required				•
DUMP BODY	Clean and check dump body condition. Check cylinders for leaks. Check hoses for chafing.	•			•
ENGINE PRE-HEATER	Check for blockage of air inlet port and hot air outlet port. Check harnesses and hoses. Remove glow pin and inspect it. Clean or replace if required.	•			•

BREAK-IN AND STORAGE GUIDELINES

The engine has been broken-in at the factory. It does not require a further break-in period. Should a replacement engine be installed in the future, the break-in must be done in accordance with the procedure in the service manual of the supplier.

If the coolant or the hydraulic oil temperature rises above the specifications, reduce the engine load or stop the engine. If the engine oil pressure goes below specifications (see the service manual of the engine supplier) reduce the engine load.

In case of problem, find out the cause and repair before restarting engine.

50-Hour Inspection

As with any precision piece of mechanical equipment, the vehicle has to be checked by a specialized mechanic after the first fifty hours of operation.

Vehicle Storage

If a vehicle is to remain idle for a prolonged period of time, certain precautions should be taken to protect it from corrosion and accumulation of rust. The following storage procedure is recommended:

- » Clean vehicle thoroughly, including the tracks;
- » If possible, park the vehicle where water accumulation, in the dump body (if equipped), will not occur;
- » Install an appropriate protector to prevent rainwater from falling in the muffler exhaust pipe;
- » Make a thorough inspection and all necessary repairs;
- » Check all points mentioned in the "Pre-Operation Inspection" section;
- » Lubricate all points of lubrication;
- » Park vehicle in a dry place or on coarse gravel;
- » Release tension on both tracks;
- » Protect the tracks from direct sunlight if storage period exceed three months;
- » Turn off the battery isolator switch;
- » Remove the batteries and connect them to a trickle charger or check and recharge monthly;
- » Completely fill the fuel tank;
- » Completely fill the DEF/AdBlue® tank;
- » Drain water from the water separator;
- » Change lubricating fluids;
- » Apply a thin coat of grease on the exposed piston rods of cylinders.

Engine Storage

Putting an engine (within the vehicle) in storage without adequate preparation will cause damages to external as well as internal surfaces and components. Refer to the engine supplier documentation for the appropriate storage procedure.

DISPOSAL

DISPOSAL

The following guidelines for hazardous waste materials must be observed when disposing of lubricant, harmful substances and other materials.

HAZARDOUS MATERIAL

CAUTION

General hazard

Waste materials can exhibit one or more hazardous characteristics.

Waste material must, under no circumstances, be mixed together.

Waste materials must be handled as per current packaging, storage and transport regulations. They must only be taken to appropriate waste disposal site.

Waste materials are to be considered as hazardous within the meaning of these instructions if they demonstrate one or more of the following characteristics:

- » Explosive;
- » Highly flammable or self igniting;
- » Flammable;
- » Act as accelerant;
- » Toxic or highly toxic;
- » Irritating and corrosive;
- » Generally harmful to health;
- » Carcinogenic or suspected to be carcinogenic;
- » Mutagenic;
- » Harmful to water or harmful in any other manner.

COLLECT, PACKAGE AND LABEL

Mixing waste materials usually makes recycling impossible or illegal.

Waste material are to be packaged according to current storage and transport regulations in such a way as to prevent leakage or evaporation and thus provide safe and secure transport.

Before being transported, the packaging, containers, and /or barrels must be clearly labelled and weather-proofed with the following information:

- » Nature of hazard;
- » Name and description of contents;
- » Hazard category and numbers;
- » Consigner (name, address and dept.);
- » Date.

Old contents information and/or supplier's labelling on containers and barrels must be removed or made illeg-

ible. The container and barrels must be rinsed out before they are filled with waste material. The only exception to this provision is if containers and barrels are filled with exactly the same waste material that they originally contained.

SHIPPING OF WASTE

Only properly packaged sealed and labelled, or approved by environmental health officials, containers and barrels may be transported to the relevant waste disposal site (waste separation).

SCRAPPING

Vehicle components, including the accessories, must be disposed of in line with relevant legal requirements.

DECLARATION OF CONFORMITY

**DICHIARAZIONE DI CONFORMITÀ**

Secondo la Direttiva Europea 2006/42/CE allegato II.A

KONFORMITÄTSERKLÄRUNG

Im Einklang mit der Europäischen Richtlinie 2006/42/EG gemäß Anhang II.A

DECLARATION OF COMPLIANCE

According to the European Directives 2006/42/EC annex II.A

DÉCLARATION DE CONFORMITÉ

Selon la directive Européenne 2006/42/CE annexe II.A

PRINOTH SpA**Brennerstr. / Via Brennero 34, IT-39049 STERZING / VIPITENO (BZ)**

<p>dichiara che il veicolo</p> <p>VEICOLO UNIVERSALE CINGOLATO Mod. PANTHER T14R con cassone Telaio no. 935310010 - ...</p> <p>è conforme alle disposizioni della Direttiva "Macchine" (2006/42/CE, e successive modifiche) e alle disposizioni di attuazione; è conforme alle disposizioni delle seguenti direttive: 2000/14/CE, 2004/26/CE, 2004/108/CE È anche conforme alle disposizioni delle seguenti Norme armonizzate: EN 474-1</p> <p>Questa dichiarazione si riferisce esclusivamente al veicolo nella condizione come è stato messo sul mercato ed esclude i componenti aggiunti e/o le modifiche effettuate successivamente dall' utente finale. Questa dichiarazione perde la sua validità se il prodotto viene adattato o modificato senza consenso.</p>	<p>bestätigt hiermit, dass das Fahrzeug</p> <p>RAUPENNUTZFAHRZEUG Mod. PANTHER T14R mit Dump-Body Rahmennr. 935310010 - ...</p> <p>die Richtlinien "Maschinen" (2006/42/EG, und die nachträglichen Abänderungen) als auch deren Durchführungsbestimmungen erfüllt; es erfüllt die Bestimmungen folgender Richtlinien: 2000/14/CE, 2004/26/CE, 2004/108/CE Und es erfüllt die Bestimmungen folgender harmonisierter Normen: EN 474-1</p> <p>Diese Erklärung bezieht sich nur auf die Maschine in dem Zustand, in dem sie in Verkehr gebracht wurde; vom Endnutzer nachträglich angebrachte Teile und/oder nachträglich vorgenommene Eingriffe bleiben unberücksichtigt. Die Erklärung verliert ihre Gültigkeit, wenn das Produkt ohne Zustimmung umgebaut oder verändert wird.</p>
<p>confirms that the vehicle</p> <p>CRAWLER UTILITY VEHICLE Mod. PANTHER T14R with dump body Frame no. 935310010 - ...</p> <p>complies with the regulations laid down in the directives "Machines" (2006/42/EC, and later modifications) and with their implementing regulations; it complies with the regulations of the following directives: 2000/14/CE, 2004/26/CE, 2004/108/CE It complies additionally with the regulations of the following harmonized norms: EN 474-1</p> <p>This declaration relates exclusively to the machinery in the state in which it was placed on the market, and excludes components which are added and/or operations carried out subsequently by the final user. The declaration is no more valid, if the product is modified without agreement.</p>	<p>déclare que le véhicule</p> <p>VÉHICULE UTILITAIRE À CHENILLES Mod. PANTHER T14R avec benne basculante Châssis no. 935310010 - ...</p> <p>se conforme aux dispositions de la directive "Machines" (2006/42/CE, et modifications successives) et aux modalités d'application ; se conforme aux dispositions des directives CE suivantes : 2000/14/CE, 2004/26/CE, 2004/108/CE</p> <p>Se conforme aussi bien aux dispositions des normes harmonisées: EN 474-1</p> <p>Cette déclaration concerne exclusivement la machine dans l'état dans lequel elle a été mise sur le marché et exclut les composants ajoutés et/ou les opérations effectuées par la suite par l'utilisateur final. Cette déclaration n'est plus valide si le produit est modifié sans autorisation.</p>

Granby 03-11-2016

PRINOTH LTD

LIST OF ABBREVIATIONS

LIST OF ABBREVIATIONS

ANSI	American National Standard Institute
A/C	Air conditioner
ASTM	American Society for Testing Material
CAN	Controller Area Network
CAT or Cat	Caterpillar
CCA	Cold Cranking Ampere
CE	Conformité Européenne
CEM	Clean Emission Module
CG	Center of Gravity
CW/CCW	Clockwise / Counter Clock wise
DEAC	Diesel Engine Antifreeze Coolant
DEF/AdBlue	Diesel Exhaust Fluid /
DEO	Diesel Engine Oil
DM1/DM2	Diagnostic Message (1 = active, 2 = previous)
DOC	Diesel Oxydation Catalyst
DPF	Diesel Particulate Filter
EDC	Electronic Displacement Control
ECM	Electronic Control Module
ELC	Extended Life Coolant
EPA	Environmental Protection Agency
EU	European Union
FMI	Failure Mode Identifier
FOPS	Falling Object Protective Structure
GVWR	Gross Vehicle Weight Rating
HP	Horse Power
ISO	International Organization for Standardiza- tion
LCD	Liquid Crystal Display
LED	Light Emitting Diode
LRC	Less Restricted Countries
MP1/MP2	Microcontroller 1 / Microcontroller 2
MSS	Motor Speed Sensor
ISO	International

OCC	Occurrence
PETU	Pump Electronics Tank Unit
ROPS	Roll Over Protective Structure
RPM	Rotation Per Minute
SAE	Society of Automotive Engineers
SCA	Supplemental Coolant Additive
SCR	Selective Catalitic Reduction
SPN	Suspect Parameter Number
Tier	Emission reduction for diesel engines
ULS / ULSD	Ultra Low Sulfur / Ultra Low Sulfur Diesel
USB	Universal Serial Bus

INDEX

A

ACCESS PANELS..... 75
 ADBLUE/DEF 71
 ALIGNMENT 32

C

CAB AIR FILTERS 159
 CONTACT 6
 COOLANT 129

D

DANGER ZONE 16
 DERATE 94
 DRIVE AND DIRECTION MISMATCH 55
 DUMP BODY OPERATION 106

E

EMERGENCY DRIVE MODULE 67
 EMERGENCY EXIT 20
 ENGINE AIR FILTER 135
 ENGINE COOLANT..... 129
 ENGINE START 87

F

FOPS 21
 FUEL 69
 FUEL FILTERS 131
 FUSES IN THE CAB 146

J

JOYSTICK 30

L

LATERAL CONSOLE 33
 LCD DISPLAY 41
 LIGHT BULBS 156
 LUBRICATION 164

M

MAINTENANCE 121

O

OVERHEAD CONSOLE 56

P

PAYLOAD 23
 PRE-HEATER 38
 PRE-OPERATION INSPECTION 79
 PRODUCT APPLICATION 22
 PUMP DRIVE 137

R

REPLACING A FUSE 146

ROPS 21

S

SAFETY MESSAGES 7
 SEAT BELT..... 64
 SHUTTING DOWN THE ENGINE 89
 SPECIFICATIONS 114
 STARTING THE ENGINE 87
 STEERING COLUMN 27
 SWING SYSTEM 151

T

TOWING 141
 TRACK TENSION 68

W

WATER SEPARATOR 71



Sales and service sites in your area to be found on www.prinoth.com

PRINOTH Ltd.

1001 J.-A.-Bombardier Street
Granby, Quebec J2J 1E9
☎ +1 450 776 3888
☎ +1 450 776 6030
prinoth.canada@prinoth.com

PRINOTH LLC

276 Seeber Drive Bldg B
Grand Junction, co 81506
☎ +1 970 242 7150
☎ +1 970 241 6722
prinoth.us@prinoth.com

PRINOTH AG

Brenerstrasse 34
I-39049 Sterzing (BZ)
☎ +39 0472 72 26 22
☎ +39 0472 72 26 16
prinoth@prinoth.com

PRINOTH AG

Gemmistrasse 45
CH-3970 Salgesch
☎ +41 (0)27 456 26 56
☎ +41 (0)27 456 47 00
info@prinoth.ch

PRINOTH GmbH

Michael-Seeber-Strasse 1
A-6410 Telfs
☎ +43 (0)526 262 121
☎ +43 (0)526 262 123 160
prinoth.austria@prinoth.ch

PRINOTH France S.A.S

5, Rue Gallée Alpespace B.P.62
F-73802 Montmelian, Cedex
☎ +33 (0)479 84 76 76
☎ +33 (0)479 84 76 77
prinoth.france@prinoth.com