

AA-9MC

ARTICULATED CRAWLER BOOM



MODEL HIGHLIGHTS

- Grey non-marking tracks
- Low emission engine
- Low ground pressure
- Reduced tail swing
- 360° continuous turntable rotation

AA-9MC Range of motion

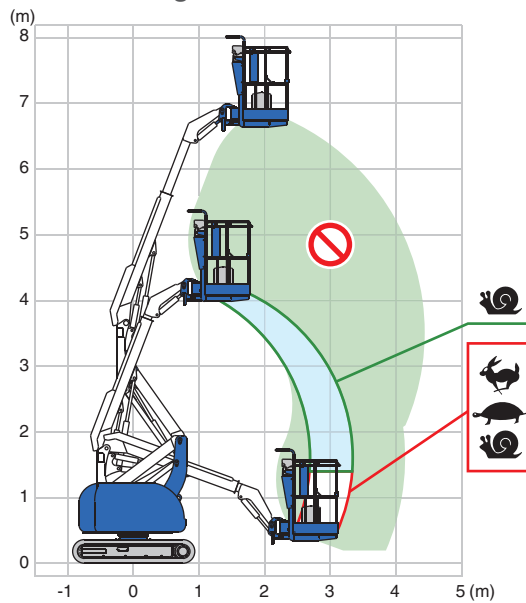

Model	AA-9MC
Max. platform capacity	150 kg
Platform size	0,92 x 0,73 x 1,10 m
Max. work height	8,80 m
Max. outreach	4,50 m

The Tadano AA-9MC is a compact and agile articulated crawler boom on rubber tracks with reduced tail swing designed for optimal efficiency.

Model		AA-9MC
SPECIFICATIONS		
Max. work height	8,80 m	
Max. outreach	4,50 m	
Allowable tilt	5°	
Max. platform capacity	150 kg	
Platform size (L x W x H)	0,92 x 0,73 x 1,10 m	
Platform rotation	L90° ~ R40°	
Transport dims (L x W x H)	4,08 x 1,65 x 2,00 m	
Machine weight	2.620 kg	
TRAVEL		
Max. travel speed	2,2 km/h	
Max. ground pressure	74 kPa	
Travel position ground pressure	42 kPa	
Max. gradeability	36%	
POWER SOURCE		
Engine type	Kubota D722	
Rated power	7,4 kW / 2000 min ⁻¹	
Fuel tank capacity	18 l	
OPTIONS		
LED lighting*		
SAFETY DEVICES		
Emergency stop		✓
Foot switch / Enabling switch		✓
Auxiliary lowering control		✓
Traveling restriction (on slope)		✓
Operation restriction (on slope)		✓
Battery isolator switch		✓

* upper control box only

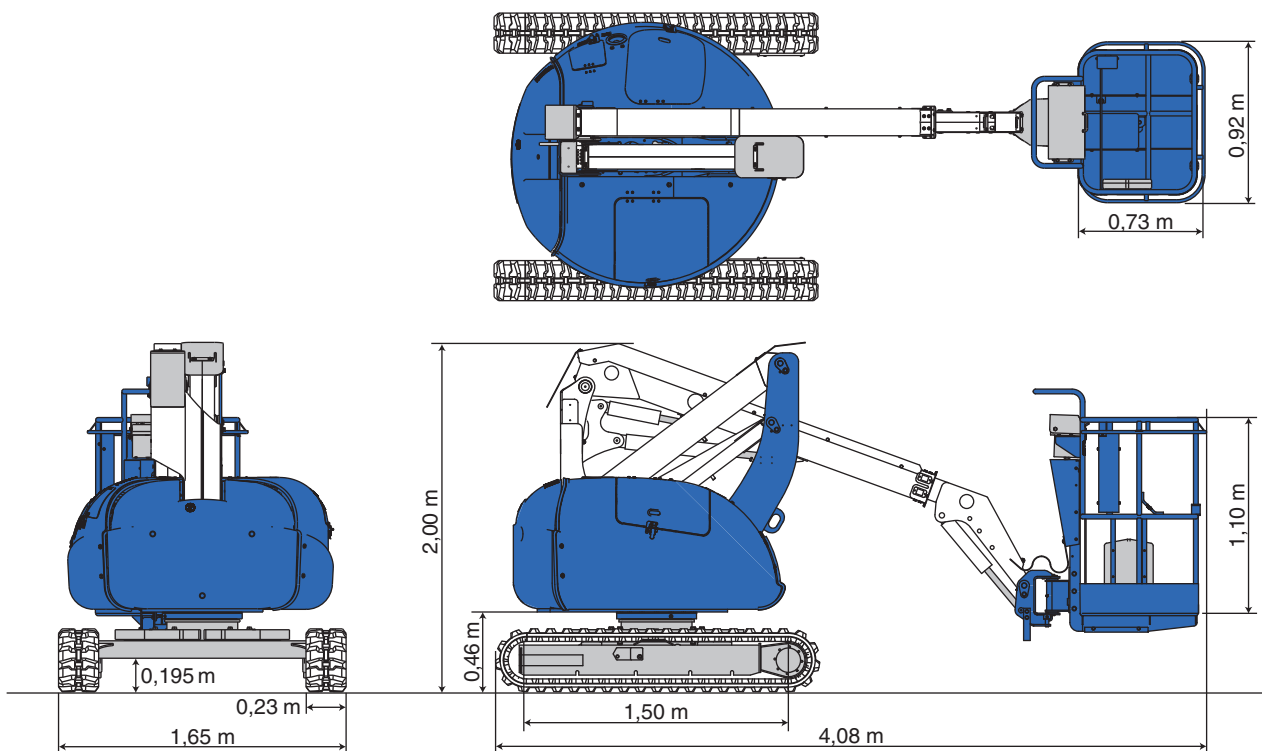

For all our types:



December 2025. Unless otherwise specified, all information in this brochure refers to a standard equipment, and it is intended as general information only. No liability is assumed. Errors reserved. Product specifications and prices are subject to changes without notice. The photographs and/or drawings in this brochure are for illustrative purposes only. For correct and safe operation, the original operating manual and lifting capacity charts are essential. Failure to follow the corresponding Operator's Manual when using our equipment or failure to otherwise act responsibly may result in property damage, serious injury or death. The sole warranty applicable with respect to our equipment is the standard warranty as per general terms and conditions of sales and service (ask your local Tadano dealer for details), and Tadano makes no other warranty, express or implied. All rights reserved. Any use of the trademarks, logos, brand names and model names used herein is prohibited.

© Tadano Ltd. 2025

Tadano Ltd.

Kanda Square 18th Floor, 2-2-1 Kanda-Nishikicho, Chiyoda-ku, Tokyo 101-0054, Japan
Phone: +81-3-6811-7309 (International Division)

info@tadano.com

www.tadano.com

Tadano Europe Holdings GmbH

Dinglerstr. 24, 66482 Zweibrücken, Germany, Phone: +49 (0) 6332 83-0

